

16 Gb x8 , 16 Gb x16, 1.8 V
NAND Flash Memory, LPDDR4x

MCP Features

- Multichip package (MCP) consists of:
 - 16Gb (4 x 4Gb) SLC NAND and 16Gb LPDDR4x SDRAM
- LPDDR4x SDRAM on Split Bus
- Low Power Supply Voltage
- Temperature range
 - Industrial: –40°C to +85°C
 - Industrial Extended: –40°C to +105°C
 - Automotive: –40°C to +85°C
 - Automotive Extended: –40°C to +105°C
- Small MCP Package
 - 8.0 x 9.5 x 1.0 mm, 149-Ball MCP

SLC NAND Flash Features

- Density
 - 16Gb (4 x 4Gb) NAND Flash Memory
- Page size
 - 4Gb: x8 (4096 + 256) bytes ;256-byte spare area
- Block Size
 - 4Gb: 64 pages : 256 KB + 16 KB
- Number of Planes
 - 4Gb = 1 plane
- Supply Voltage
 - Vcc = 1.7V to 1.95V

LPDDR4x SDRAM Features

- Density
 - 16Gb (2 x 8Gb) LPDDR4x SDRAM
- Device Bus Width: x16
- Speed : 1866 MHz, 2133 MHz
- Configured as 1-channel memory with 8-bank memory
- All bank auto refresh and directed per bank auto refresh supported
- Low-voltage core and I/O power supply
 - VDD1 = 1.8 (1.70–1.95V);
 - VDD2 = 1.1V (1.06–1.17V);
 - VDDQ = 0.6V (0.57V - 0.65V)
- Programmable CA ODT and DQ ODT with VSSQ termination
- Single data rate command and address entry
- Bi-directional differential data strobe (DQS_t, DQS_c)

Contents

MCP Features	1
LPDDR4x SDRAM Features	1
SLC NAND Flash Features	1
1. Ordering Information	7
2. Product Block Diagram.....	8
3. Connection Diagrams.....	9
4. Input / Output Descriptions	10
5. Physical Dimensions.....	11
S34MS04G2: 4Gbit, x8, 1.8V SLC NAND Flash	12
Distinctive Characteristics.....	12
1. General Description	13
1.4 Block Diagram	14
1.5 Array Organization.....	15
1.6 Addressing.....	16
1.7 Mode Selection	17
2. Bus Operation	18
2.1 Command Input	18
2.2 Address Input.....	18
2.3 Data Input	18
2.4 Data Output	18
2.5 Write Protect	18
2.6 Standby	18
3. Command Set	19
3.1 Page Read	20
3.2 Page Program.....	20
3.4 Page Reprogram	20
3.5 Block Erase.....	22
3.6 Copy Back Program.....	23
3.7 Read Status Register.....	24
3.8 Read Status Enhanced	24
3.9 Read Status Register Field Definition	24
3.11 Read Cache	25
3.12 Cache Program	26
3.13 Read ID.....	27
3.14 Read ID2.....	29
3.15 Read ONFI Signature.....	29
3.16 Read Parameter Page.....	29
3.17 Read Unique ID (Contact Factory)	32
4. Signal Descriptions	34
4.1 Data Protection and Power On / Off Sequence	34
4.2 Ready/Busy	34
4.3 Write Protect Operation	35
5. Electrical Characteristics	36
5.1 Valid Blocks	36
5.3 AC Test Conditions	36
5.4 AC Characteristics	37
5.5 DC Characteristics.....	38
5.6 Pin Capacitance.....	39
5.7 Program / Erase Characteristics	39
6. Timing Diagrams	40
6.1 Command Latch Cycle.....	40
6.2 Address Latch Cycle.....	41
6.3 Data Input Cycle Timing.....	41
6.4 Data Output Cycle Timing (CLE=L, WE#=H, ALE=L, WP#=H)	42
6.5 Data Output Cycle Timing (EDO Type, CLE=L, WE#=H, ALE=L)	42
6.6 Page Read Operation	43
6.7 Page Read Operation (Interrupted by CE#).....	43
6.8 Page Read Operation Timing with CE# Don't Care	44
6.9 Page Program Operation	44
6.10 Page Program Operation Timing with CE# Don't Care.....	45

6.11	Page Program Operation with Random Data Input	45
6.12	Random Data Output In a Page	46
6.13	Block Erase Operation	46
6.14	Copy Back Read with Optional Data Readout	47
6.15	Copy Back Program Operation With Random Data Input	47
6.16	Read Status Register Timing	47
6.17	Read Status Enhanced Timing	48
6.18	Reset Operation Timing	48
6.19	Read Cache	49
6.20	Cache Program	51
6.21	Read ID Operation Timing	52
6.22	Read ID2 Operation Timing	52
6.23	Read ONFI Signature Timing	53
6.24	Read Parameter Page Timing	53
6.25	Read Unique ID Timing (Contact Factory)	54
6.26	Read ID Operation Timing	54
6.27	Power On and Data Protection Timing	55
6.28	WP# Handling	56
7.	System Interface	57
8.	Error Management	59
8.1	System Bad Block Replacement	59
8.2	Bad Block Management	60
8Gbit LPDDR4X SDRAM		61
FEATURES		61
1.	Functional Description	63
1.1.	LPDDR4 SDRAM Addressing	64
1.2.	Simplified State Diagram	64
1.3.	Power-up and Initialization	66
1.3.1	Voltage Ramp and Device Initialization	66
1.3.2	Reset Initialization with Stable Power	68
1.3.3	Power-off Sequence	73
1.3.4.	Uncontrolled Power-off Sequence	73
1.4.	Mode Register Definition	74
1.4.1	MR0 Register Information (MA[5:0] = 00H)	76
1.4.2	MR1 Register Information (MA[5:0] = 01H)	77
1.4.2.1	Burst Sequence	78
1.4.3	MR2 Register Information (MA[5:0] = 02H)	79
1.4.3.1.	Read and Write Latencies (Frequency Ranges for RL, WL, and nWR Settings)	80
1.4.4.	MR3 Register Information (MA[5:0] = 03H)	80
1.4.5.	MR4 Register Information (MA[5:0] = 04H)	81
1.4.6.	MR5 Register Information (MA[5:0] = 05H)	82
1.4.7.	MR6 Register Information (MA[5:0] = 06H)	83
1.4.8.	MR7 Register Information (MA[5:0] = 07H)	83
1.4.9.	MR8 Register Information (MA[5:0] = 08H)	83
1.4.10.	MR9 Register Information (MA[5:0] = 09H)	84
1.4.11.	MR10 Register Information (MA[5:0] = 0AH)	84
1.4.12.	MR11 Register Information (MA[5:0] = 0BH)	84
1.4.13.	MR12 Register Information (MA[5:0] = 0CH)	85
1.4.14.	MR13 Register Information (MA[5:0] = 0DH)	88
1.4.15.	MR14 Register Information (MA[5:0] = 0EH)	89
1.4.16.	MR15 Register Information (MA[5:0] = 0FH)	91
1.4.17.	MR16 Register Information (MA[5:0] = 10H)	92
1.4.18.	MR17 Register Information (MA[5:0] = 11H)	93
1.4.19.	MR18 Register Information (MA[5:0] = 12H)	94
1.4.20.	MR19 Register Information (MA[5:0] = 13H)	95
1.4.21.	MR20 Register Information (MA[5:0] = 14H)	96
1.4.22.	MR21 Register Information (MA[5:0] = 15H)	96
1.4.23.	MR22 Register Information (MA[5:0] = 16H)	97
1.4.24.	MR23 Register Information (MA[5:0] = 17H)	99
1.4.25.	MR24 Register Information (MA[5:0] = 18H)	100
1.4.26.	MR25 Register Information (MA[5:0] = 19H)	101
1.4.27.	MR26:31 Register Information (MA[5:0] = 1AH:1FH)	101

1.4.28.	MR32 Register Information (MA[5:0] = 20H).....	102
1.4.31.	MR33:39 Register Information (MA[5:0] = 26H:27H).....	102
1.4.32.	MR40 Register Information (MA[5:0] = 28H).....	103
2.	LPDDR4 Command Definitions and Timing Diagrams.....	104
2.1.	Activate Command.....	104
2.2.	8-Bank Device Operation.....	104
2.3.	Core Timing.....	106
2.4.	Read and Write Access Operations.....	107
2.5.	Read Preamble and Postamble.....	108
2.6.	Burst Read Operation.....	109
2.7.	Read Timing.....	111
2.8.	tLZ(DQS), tLZ(DQ), tHZ(DQS), tHZ(DQ) Calculation.....	112
2.8.1.	tLZ(DQS) and tHZ(DQS) Calculation for ATE (Automatic Test Equipment).....	112
2.8.2.	tLZ(DQ) and tHZ(DQ) Calculation for ATE (Automatic Test Equipment).....	112
2.8.3.	tRPRE Calculation for ATE (Automated Test Equipment).....	116
2.8.4.	tRPST Calculation for ATE (Automatic Test Equipment).....	117
2.9.	tDQSCK Timing Table.....	119
2.9.1	CK to DQS Rank to Rank Variation.....	124
2.10.	Write Preamble and Postamble.....	120
2.11.	Burst Write Operation.....	122
2.12.	Write Timing.....	124
2.12.1.	tWPRE Calculation for ATE (Automated Test Equipment).....	125
2.12.2.	tWPST Calculation for ATE (Automatic Test Equipment).....	126
2.13.	Read and Write Latencies.....	128
2.14.	Write and masked write operation DQS control (WDQS control).....	129
2.14.1.	WDQS Control Mode 1 - Read Based Control.....	130
2.14.2.	WDQS Control Mode 2 - WDQS_on/off.....	131
2.15.	Postamble and Preamble merging behavior.....	134
2.15.1.	Read to Read Operation.....	134
2.15.2.	Write to write Operation.....	134
2.16.	Masked Write Operation.....	146
2.16.1.	Masked Write Timing constraints.....	147
2.17.	LPDDR4 Data Mask (DM) and Data Bus Inversion (DBI _{dc}) Function.....	149
2.18.	Precharge Operation.....	152
2.18.1.	Burst Read Operation followed by Precharge.....	153
2.18.2.	Burst Write followed by Precharge.....	154
2.18.3.	Auto Precharge operation.....	155
2.18.4.	Burst Read with Auto-Precharge.....	156
2.18.5.	Burst Write with Auto-Precharge.....	158
2.18.6.	Delay Time from Write to Read with Auto Precharge.....	158
2.19.	Refresh command.....	162
2.19.1.	Burst Read Operation Followed by Per Bank Refresh.....	169
2.20.	Refresh Requirements.....	170
2.21.	Self Refresh Operation.....	171
2.21.1.	Self Refresh Entry and Exit.....	171
2.21.2.	Power Down Entry and Exit during Self Refresh.....	173
2.21.2.1.	Partial Array Self-Refresh (PASR).....	174
2.21.2.1.1	PASR Bank Masking.....	174
2.21.2.1.2	PASR Segment Masking.....	174
2.21.3.	Command Input Timing after Power Down Exit.....	175
2.22.	Self Refresh Abort.....	177
2.23.	MRR, MRW, MPC Command during tXSR, tRFC.....	178
2.24.	Mode Register Read (MRR) command.....	179
2.24.1.	MRR after Read and Write command.....	181
2.24.2.	MRR after Power-Down Exit.....	183
2.25.	Mode Register Write (MRW) Operation.....	184
2.25.1.	Mode Register Write.....	184
2.26.	Vref Current Generator (VRCG).....	187
2.27.	CA Vref Training.....	189
2.28.	DQ Vref Training.....	195

2.29.	Command Bus Training.....	201
2.29.1.	Command Bus Training for x16 mode.....	201
2.29.1.1.	Training Sequence for single-rank systems:.....	202
2.29.1.2.	Training Sequence for multi-rank systems:.....	203
2.29.1.3.	Relation between CA input pin and DQ output pin.....	203
2.29.1.4.	Timing Diagram.....	204
2.29.1.5.	Command Bus Training AC Timing Table.....	202
2.29.2.	Command Bus Training for x8 mode.....	209
2.29.2.1.	Training Mode 1.....	209
2.29.2.1.1	Training Sequence for single-rank systems:.....	210
2.29.2.1.2	Training Sequence for multi-rank systems:.....	211
2.29.2.1.3.	Relation between CA input pin and DQ output pin.....	211
2.29.2.1.4.	Timing Diagram.....	212
2.29.2.1.5.	AC Timing.....	215
2.29.2.2.	Training Mode 2.....	216
2.29.2.2.1	Training Sequence for single-rank systems:.....	217
2.29.2.2.2	Training Sequence for multi-rank systems:.....	217
2.29.2.2.3.	Relation between CA input pin and DQ output pin.....	218
2.29.2.2.4.	Timing Diagram.....	219
2.29.2.2.5.	AC Timing.....	223
2.30.	Frequency Set Point (FSP).....	225
2.30.1.	Frequency Set Point update timing.....	227
2.31.	Mode Register Write Leveling -WR Leveling Mode.....	231
2.31.1.	Write Leveling Procedure.....	231
2.31.2.	Input Clock Frequency Stop and Change.....	233
2.31.3.	Write Leveling Setup and Hold Time.....	234
2.32.	RD DQ Calibration.....	235
2.32.1	RD DQ Calibration for Byte x8 Mode.....	235
2.32.1.1	RD DQ Calibration Training.....	235
2.32.1.2.	RD DQ Read Training Example.....	236
2.33.	DQS-DQ Training.....	237
2.33.1.	FIFO Pointer Reset and Synchronism.....	238
2.34.	DQS Interval Oscillator.....	242
2.34.1.	Interval Oscillator matching error.....	244
2.34.2.	DQS Interval Oscillator Readout Timing.....	246
2.35.	Read Preamble Training.....	247
2.36.	Multi Purpose Command(MPC).....	249
2.37.	Thermal offset.....	254
2.38.	Temperature Sensor.....	255
2.39.	ZQ Calibration.....	257
2.39.1.	ZQ Cal Reset.....	257
2.39.3.	ZQ External Resistor, Tolerance, and Capacitive Loading.....	259
2.39.3.1.	ZQ Wiring for Byte-mode PKG including mixed configuration.....	260
2.40.	Pull-down and Pull-up driver characteristics and Calibration point.....	261
2.41.	On Die Termination Command/Address Bus.....	262
2.41.1.	ODT Mode Register and ODT State Table.....	263
2.41.2.	ODT Mode Register and ODT characteristics.....	264
2.41.3.	ODT for Command/Address update time.....	266
2.42.	On-die Termination.....	267
2.42.1.	ODT Mode Register.....	267
2.42.2.	Asynchronous ODT.....	267
2.42.3.	ODT during Write Leveling.....	271
2.43.	On Die Termination for DQ, DQS and DMI.....	272
2.44.	Output Driver and Termination Register Temperature and Voltage Sensitivity.....	274
2.45.	Power Down Mode.....	275
2.45.1.	Power Down Entry and Exit.....	275
2.46.	Input clock stop and frequency change.....	284
2.47.	Truth Tables.....	286
2.47.1.	Command Truth Table.....	286
2.48.	TRR Mode - Target Row Refresh.....	288
2.48.1.	TRR Mode Operation.....	289

2.49.	Post Package Repair - PPR.....	291
2.49.1.	Fail Row Address Repair	291
3.	Absolute Maximum DC Ratings	293
4.	AC and DC Operating Conditions.....	294
4.1	Recommended DC Operating Conditions.....	294
4.2	Input Leakage Current	294
4.3.	Input/Output Leakage Current.....	294
4.4.	Operating Temperature.....	294
5.	AC and DC Input Measurement Levels.....	295
5.1	1.1V High speed LVCMOS (HS_LLVC MOS).....	295
5.1.1.	Standard specifications.....	295
5.1.2.	DC Electrical Characteristics.....	295
5.1.2.1	Input Level for CKE.....	295
5.1.2.2.	LPDDR4 Input Level for Reset_n and ODT_CA.....	296
5.1.3.	AC Over/Undershoot.....	297
5.1.3.1.	LPDDR4 AC Over/Undershoot.....	297
5.2.	Differential Input Voltage.....	298
5.2.1.	Differential Input Voltage for CK.....	298
5.2.2.	Peak Voltage Calculation Method.....	299
5.2.3.	Single-Ended Input Voltage for Clock.....	300
5.2.4.	Differential Input Slew Rate for Clock.....	301
5.2.5	Differential Input Cross Point Voltage.....	302
5.2.6.	Differential Input Voltage for DQS.....	303
5.2.7.	Peak Voltage Calculation Method.....	304
5.2.8.	Single-Ended Input Voltage for DQS.....	305
5.2.9.	Differential Input Slew Rate Definition for DQS.....	306
5.2.10	Differential Input Cross Point Voltage.....	307
5.3.	Input Levels for ODT (ca) Input.....	308
5.4.	Single Ended Output Slew Rate.....	308
5.5.	Differential Output Slew Rate.....	309
5.6.	Overshoot and Undershoot Specification for LVSTL.....	310
5.7.	LVSTL Driver Output Timing Reference Load.....	311
5.8.	LVSTL (Low Voltage Swing Terminated Logic) IO System.....	312
6.	Input/Output Capacitance	314
7.	IDD Specification Parameters and Test Conditions	315
7.1.1.	IDD Measurement Conditions	315
7.1.2.	Definition for tCK(abs)	331
8.	Electrical Characteristics and AC Timings	334
8.1.1.	Definition for tCK(avg) and nCK.....	334
8.1.2.	Definition for tCK(abs).....	334
8.1.3.	Definition for tCh(avg) and tCL(avg).....	334
8.1.4.	Definition for tCH(abs) and tCL(abs).....	335
8.1.5.	Definition for tJIT(per).....	335
8.1.6.	Definition for tJIT(cc).....	335
8.2.	Definition for tCK(abs).....	336
8.3.	Definition for tCh(avg) and tCL(avg).....	337
8.4.	Definition for tCH(abs) and tCL(abs).....	338
8.5.	Definition for tJIT(per).....	341
8.6.	Definition for tJIT(cc).....	342
9.	IDD Measurement	346
10.	Revision History.....	349
10.1	Document History Page.....	349

1. Ordering Information

The order number (Valid Combination) is formed by the following:

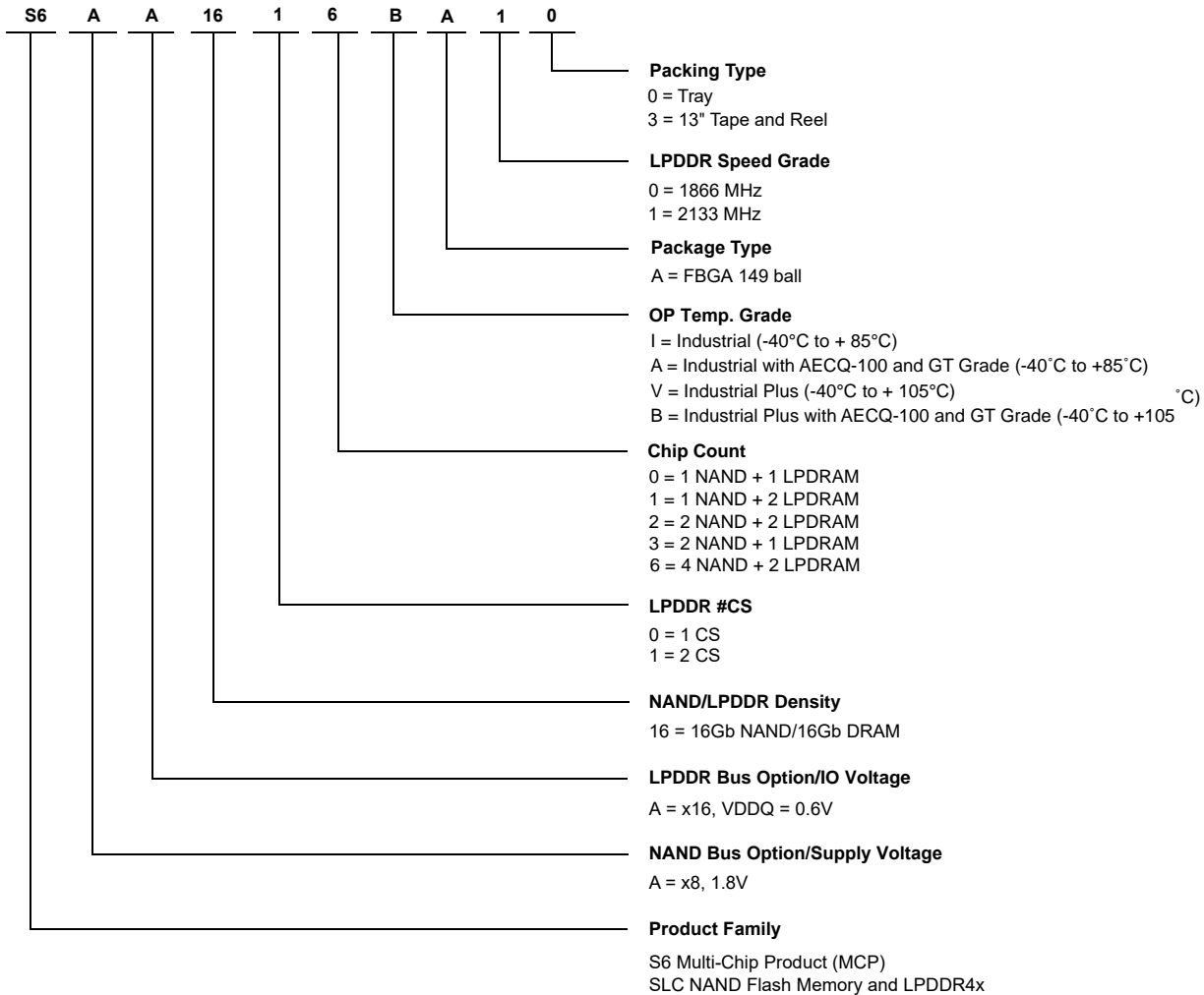

1.1 Valid Combinations

Valid Combinations list configurations planned to be supported in volume for this device. Consult your local sales office to confirm availability of specific valid combinations and to check on newly released combinations.

Device Family	NAND Voltage/ Bus	LPDDR Voltage/ Bus	NAND/LPDDR Density	LPDDR #CS	Chip Count	Temp. Grade	Package Type	LPDDR Speed Grade	Packing Type	Package
S6	A	A	16	1	6	B	A	1	0	149-ball FBGA

2. Product Block Diagram

Figure 2.1 Block Diagram

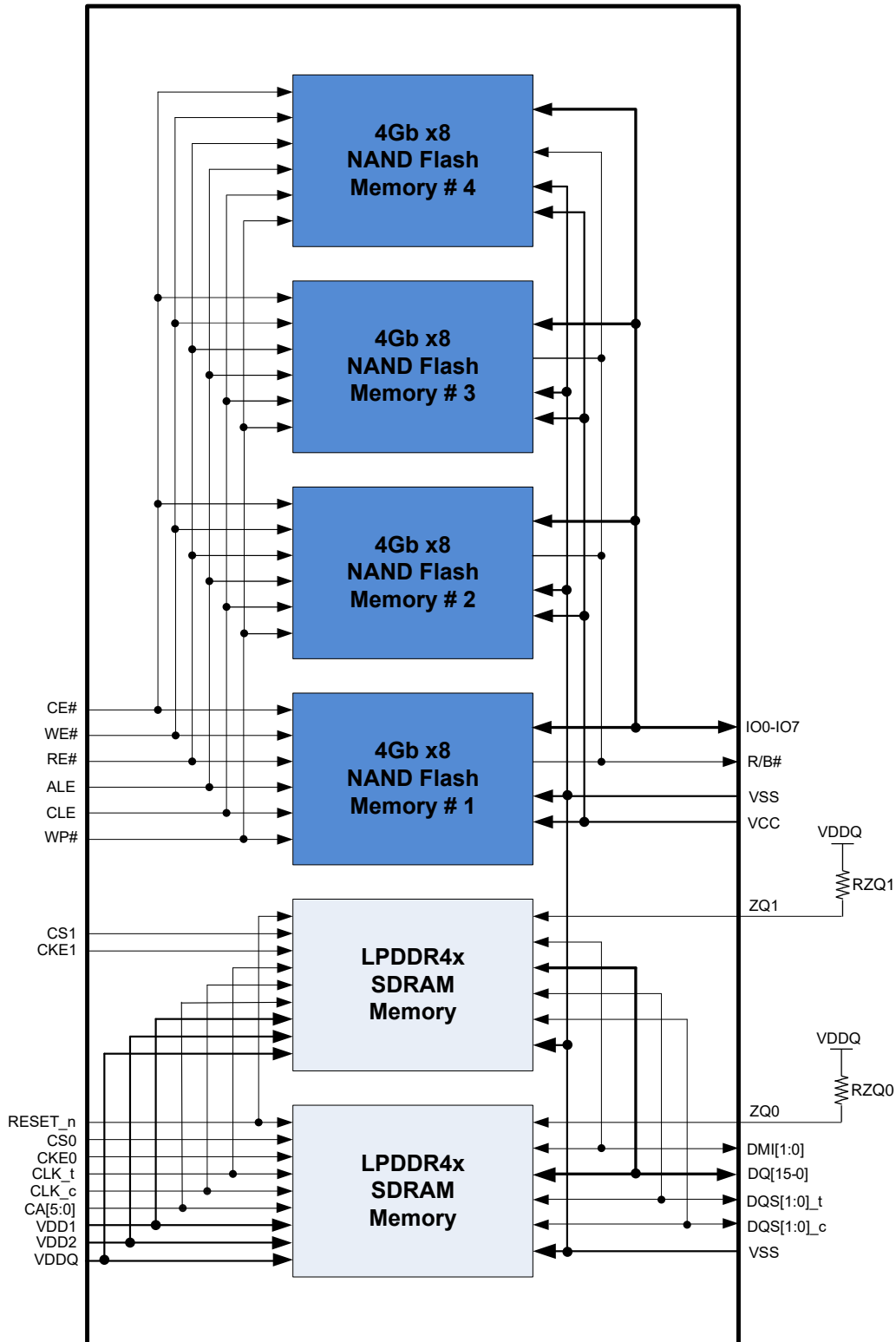

3. Connection Diagrams

Figure 3.1 149-Ball Ball Grid Array MCP

	1	2	3	4	5	6	7	8	9	10	11	12	13	14
A	DNU	DNU											DNU	DNU
B	DNU	NC	NC	NC	NC	NC	NC			NC	NC	VCC	NC	DNU
C	NC	NC	NC	WP#	R/B#	Vss	WE#			Vss	IO7	IO6	VCC	NC
D	NC	NC	NC	NC	CE#	Vss	RE#			ALE	Vss	Vss	IO1	IO4
E					VDD2	VDD2	VDD2			Vss	IO2	IO5	Vcc	Vcc
F	DQ10	VDD2	DQ8	DQ9	Vss	Vss	DQS1_t			CLE	Vss	Vss	IO3	IO0
G	DQ11	VDDQ	VDDQ	Vss	DQ12	VDDQ	DQS1_c				NC	NC	NC	NC
H	DMI1	Vss	VDDQ	DQ14	Vss	DQ15	VDDQ				Vss	NC	Vss	CLK_t
J	DQ13	Vss	Vss	Vss	VDD2	VDD2	VDD2				Vss	CA0	Vss	CLK_c
K											CA1	Vss	CS1	CKE1
L											CA4	Vss	CS0	CKE0
M	DQ3	Vss	DMI0	Vss	DQ6	Vss	DQS0_c				CA3	Vss	Vss	RESET_n
N	DQ2	Vss	Vss	DQ5	Vss	DQ7	DQS0_t				CA2	Vss	CA5	ZQ1
P	DQ1	DQ0	VDDQ	Vss	DQ4	Vss	VDD2				VDD2	VDD2	VDD1	ZQ0
R	DNU	VDD1	VDD2	VDDQ	VDDQ	VDD2	VDD1				VDDQ	VDDQ	VDD1	DNU
T	DNU	DNU											DNU	DNU

TOP VIEW (ball down)



4. Input / Output Descriptions

Figure 4.1 Input / Output Descriptions

Symbol	Description	NAND	DRAM
IO7 – IO0	Flash Multiplexed Address and Data	X	
CE#	Flash Chip-enable Input.	X	
RE#	Read Enable	X	
RB#	Ready Busy	X	
WE#	Flash Write Enable Input	X	
WP#	Write Protect	X	
CLE	Command Latch Enable	X	
ALE	Address Latch Enable	X	
VCC	Flash Power Supply	X	
DQ15 – DQ0	SDRAM Data Input/Output		X
CLK_t, CLK_c	Differential Clock inputs		X
CEK0, CEK1	Clock Enable		X
CS0, CS1	Chip Enable		X
CA5 – CA0	Command/Address Input		X
DQS0_t – DQS0_c	Bi-directional Differential Output Clock signals		X
DQS1_t – DQS1_c	Bi-directional Differential Output Clock Signals		X
DMI0, DMI1	Data Mask/ Data Bus Inversion		X
ZQ0, ZQ1	Calibration Reference		X
Reset_n	Reset		X
VDD1, VDD2, VDDQ	Power Supplies - Isolated		X
VSS	Ground	X	X
NC	No Connect		
DNU	Do not Use		
RFU	Reserved for Future Use		

5. Physical Dimensions

5.1 149 Ball (FBGA)8.0 x 9.5 x 1.0 mm

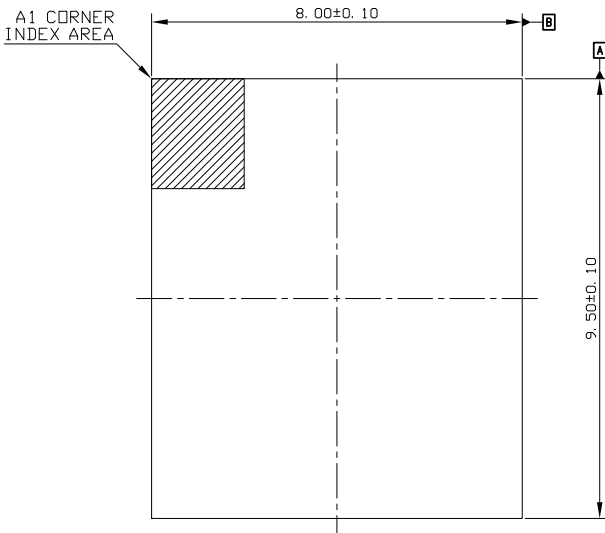

TOP VIEW

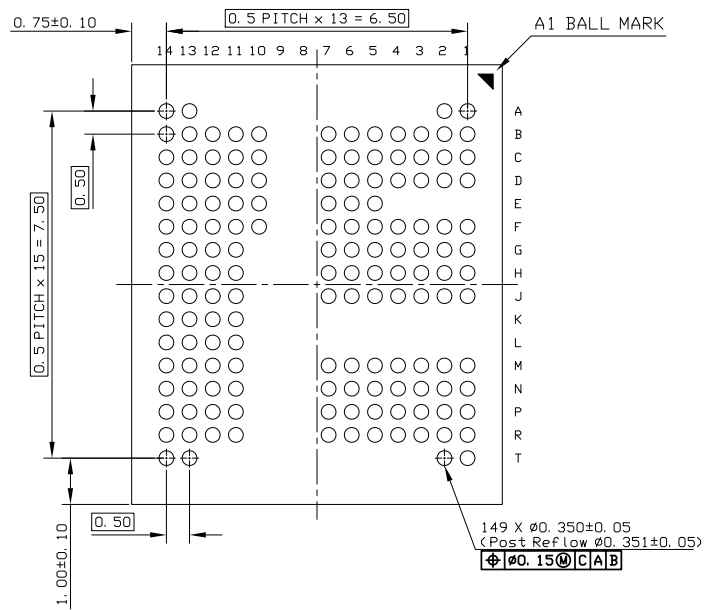

BOTTOM VIEW

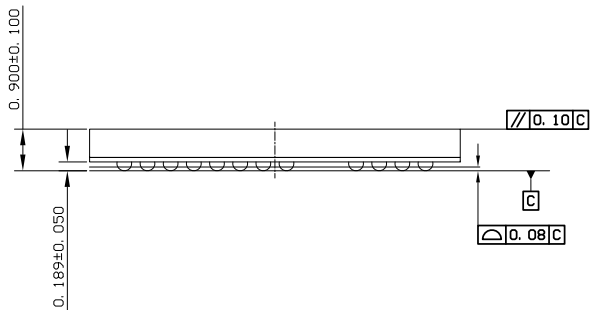

SIDE VIEW

- Notes:
1. All measurements are in millimeters
 2. Package height does not include room temperature warpage
 3. Solder ball composition: SAC408 with OSP pads

S34MS04G2: 4Gbit, x8, 1.8V SLC NAND Flash

Distinctive Characteristics

- Density
 - 4 Gb
- Architecture
 - Input / Output Bus Width: 8 bits
 - Page size:
 - 4 Gb: (4096 + 256) bytes; 256-byte spare area
 - Block size: 64 Pages
 - 256 KB + 16 KB
 - Plane size:
 - 2048 Blocks (256 MB + 16 MB)
 - Device size:
 - 1 plane per device or 512 MB
- NAND flash interface
 - Open NAND Flash Interface (ONFI) 1.0 compliant
 - Address, Data, and Commands multiplexed
- Supply voltage
 - 1.8 V device: $V_{CC} = 1.7\text{ V} \sim 1.95\text{ V}$
- Security
 - One Time Programmable (OTP) area
 - Serial number (unique ID) (Contact factory for support)
 - Hardware program/erase disabled during power transition
- Electronic signature
 - Manufacturer ID: 01h
- Operating temperature
 - Industrial: $-40\text{ }^{\circ}\text{C}$ to $85\text{ }^{\circ}\text{C}$
 - Industrial Plus: $-40\text{ }^{\circ}\text{C}$ to $105\text{ }^{\circ}\text{C}$
- Reliability
 - 100,000 Program / Erase cycles (Typ) (with 4-bit ECC per 544 bytes (x8))
 - 10-year Data retention (Typ)
 - Block zero is valid and will be valid for at least 1,000 program-erase cycles with ECC

Performance

- Page Read / Program
 - Random access: 30 μs (Max)
 - Sequential access: 45 ns (Min)
 - Program time: 300 μs (Typ)
- Block Erase
 - Block Erase time: 3.5 ms (Typ)

1. General Description

The SkyHigh S34MS04G2 series is offered in 1.8 V_{CC} and V_{CCQ} power supply, and with x8 I/O interface. Its NAND cell provides the most cost-effective solution for the solid state mass storage market. The memory is divided into blocks that can be erased independently so it is possible to preserve valid data while old data is erased. The page size for x8 is (4096 + spare) bytes.

Each block can be programmed and erased up to 100,000 cycles with ECC (error correction code) on. To extend the lifetime of NAND flash devices, the implementation of an ECC is mandatory.

The chip supports CE# don't care function. This function allows the direct download of the code from the NAND flash memory device by a microcontroller, since the CE# transitions do not stop the read operation.

The devices have a Read Cache feature that improves the read throughput for large files. During cache reading, the devices load the data in a cache register while the previous data is transferred to the I/O buffers to be read.

Like all other 4-KB page NAND flash devices, a program operation typically writes 4 KB (x8) in 300 µs and an erase operation can typically be performed in 3.5 ms.

In the Read operations, data in the page can be read out at 45 ns cycle time per byte. The I/O pins serve as the ports for command and address input as well as data input/output. This interface allows a reduced pin count and easy migration towards different densities, without any rearrangement of the footprint.

Commands, Data, and Addresses are asynchronously introduced using CE#, WE#, ALE, and CLE control pins.

The on-chip Program/Erase Controller automates all read, program, and erase functions including pulse repetition, where required, and internal verification and margining of data. A WP# pin is available to provide hardware protection against program and erase operations.

The output pin R/B# (open drain buffer) signals the status of the device during each operation. It identifies if the program/erase/read controller is currently active. The use of an open-drain output allows the Ready/Busy pins from several memories to connect to a single pull-up resistor. In a system with multiple memories the R/B# pins can be connected all together to provide a global status signal.

The Reprogram function allows the optimization of defective block management — when a Page Program operation fails the data can be directly programmed in another page inside the same array section without the time consuming serial data insertion phase.

The devices provide an innovative feature: Page Reprogram. The Page Reprogram re-programs one page. Normally, this operation is performed after a failed Page Program operation.

The devices come with the following security features:

- OTP (one time programmable) area, which is a restricted access area where sensitive data/code can be stored permanently.
- Serial number (unique identifier), which allows the devices to be uniquely identified. Contact factory for support of this feature.

These security features are subject to an NDA (non-disclosure agreement) and are, therefore, not described in the data sheet. For more details about them, contact your nearest SkyHigh sales office.

Device	Density (bits)		Number of Planes	Number of Blocks per Plane
	Main	Spare		
S34MS04G2	512M x 8	32M x 8	1	2048

1.1 Logic Diagram

Figure 1.1 Logic Diagram

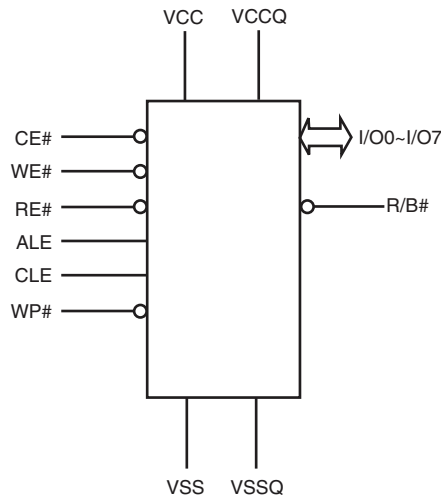
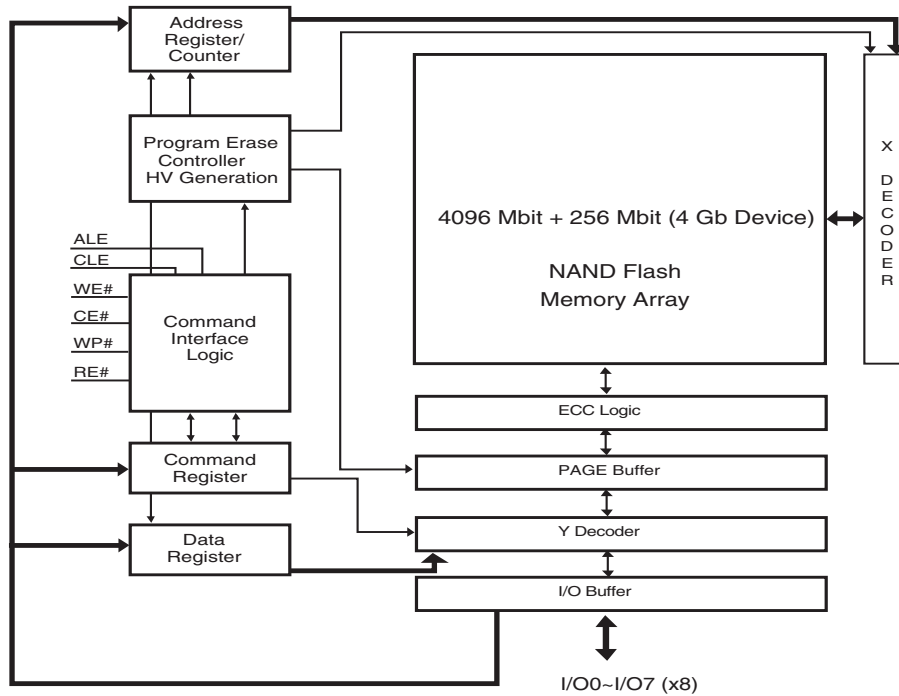

Table 1.1 Signal Names

I/O7 - I/O0 (x8)	Data Input / Outputs
CLE	Command Latch Enable
ALE	Address Latch Enable
CE#	Chip Enable
RE#	Read Enable
WE#	Write Enable
WP#	Write Protect
R/B#	Read/Busy
VCC	Power Supply
VSS	Ground
NC	Not Connected

1.3 Block Diagram

Figure 1.6 Functional Block Diagram



1.4 Array Organization

Figure 1.7 Array Organization

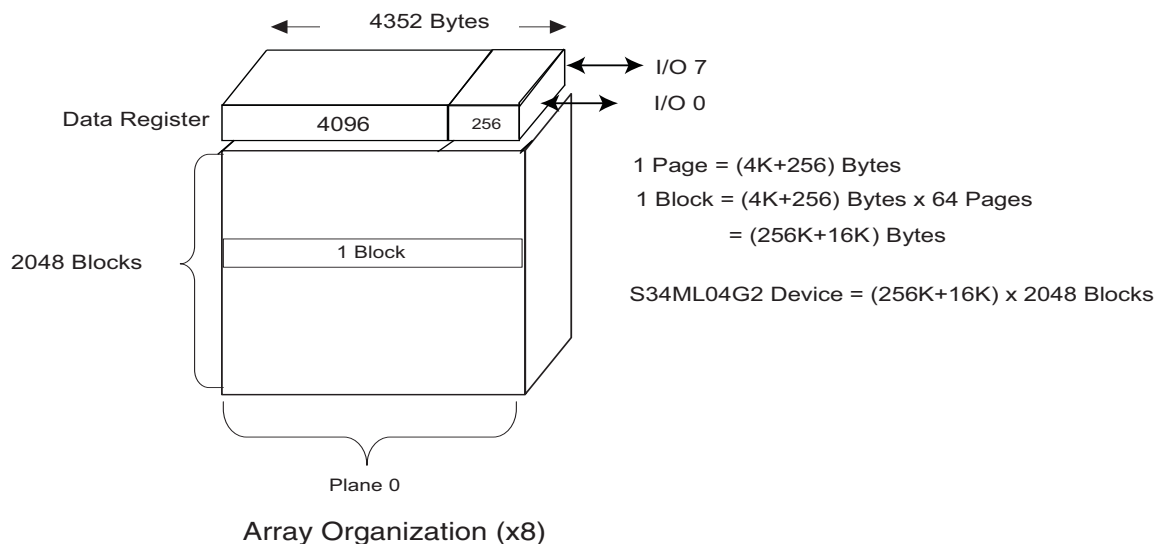

1.5 Addressing

1.6.1 Memory Address Phase Cycles

Table 4 provides the memory organization and the address bit requirements for each devices supported.

Table 4. Memory Array Organization and Address Bit Requirements

Density Page Size	Device and Array Organization											Address bits
	Page Size	LUN	Planes	#block per Plane	Page per Block	Spare Byte per Page	Spare Byte per NOP	NOP	Partial Word Size	CA Bits	PA Bits	BA Bits
04Gb	4KB	1	1	2048	64	256	64	4	1024B	13	6	11

Legend:

CA = Column address bit.

PA = Page Address bit.

BA = Block Address bit.

Table 5 provides the address phase cycles for the X8 mode of operation.

Table 5. Address Phase Cycles for X8 Mode of Operation

Bus Cycle	Name	IO[7]	IO[6]	IO[5]	IO[4]	IO[3]	IO[2]	IO[1]	IO[0]
1st	Col Add 1 (C1)	CA[7]	CA[6]	CA[5]	CA[4]	CA[3]	CA[2]	CA[1]	CA[0]
2nd	Col Add 2 (C2)	L	L	L	CA[12]	CA[11]	CA[10]	CA[9]	CA[8]
3rd	Row Add 1 (R1)	BA[1]	BA[0]	PA[5]	PA[4]	PA[3]	PA[2]	PA[1]	PA[0]
4th	Row Add 2 (R2)	BA[9]	BA[8]	BA[7]	BA[6]	BA[5]	BA[4]	BA[3]	BA[2]
5th	Row Add 3 (R3)	L	L	L	L	L	L	L	BA[10]

Note

4. Block address concatenated with page address = actual page address, also known as the row address.

Legend:

CAx = Column Address bit.

Pax = Page Address bit.

Bax = Block Address bit.

Density_Page Size	x8 Bus Width	Additional Notes
	CA[12:0]	
04Gb_4KB	CA[12:0]	If CA[12] = 1, then CA[10:7] must be low

Note

5. Block address BA[10:0].

Density_Page Size	#of LUNs	# of Planes	#Blocks per Plane	BA	Additional Notes
04Gb_4KB	1	1	2048	BA[10:0]	

1.6 Mode Selection

Table 1.6 Mode Selection

Mode		CLE	ALE	CE#	WE#	RE#	WP#
Read Mode	Command Input	High	Low	Low	Rising	High	X
	Address Input	Low	High	Low	Rising	High	X
Program or Erase Mode	Command Input	High	Low	Low	Rising	High	High
	Address Input	Low	High	Low	Rising	High	High
Data Input		Low	Low	Low	Rising	High	High
Data Output (on going)		Low	Low	Low	High	Falling	X
Data Output (suspended)		X	X	X	High	High	X
Busy Time in Read		X	X	X	High	High (3)	X
Busy Time in Program		X	X	X	X	X	High
Busy Time in Erase		X	X	X	X	X	High
Write Protect		X	X	X	X	X	Low
Stand By		X	X	High	X	X	0V / V _{CC} (2)

Notes:

1. X can be V_{IL} or V_{IH}. High = Logic level high. Low = Logic level low.
2. WP# should be biased to CMOS high or CMOS low for stand-by mode.
3. During Busy Time in Read, RE# must be held high to prevent unintended data out.

2. Bus Operation

There are six standard bus operations that control the device: Command Input, Address Input, Data Input, Data Output, Write Protect, and Standby. (See [Table 1.6.](#))

Typically glitches less than 5 ns on Chip Enable, Write Enable, and Read Enable are ignored by the memory and do not affect bus operations.

2.1 Command Input

The Command Input bus operation is used to give a command to the memory device. Commands are accepted with Chip Enable low, Command Latch Enable high, Address Latch Enable low, and Read Enable high and latched on the rising edge of Write Enable. Moreover, for commands that start a modify operation (program/erase) the Write Protect pin must be high. See [Figure 6.1](#) and [Table 5.4](#) for details of the timing requirements. Command codes are always applied on I/O7:0.

2.2 Address Input

The Address Input bus operation allows the insertion of the memory address. For S34MS04G2 devices, five write cycles are needed to input the addresses. Addresses are accepted with Chip Enable low, Address Latch Enable high, Command Latch Enable low, and Read Enable high and latched on the rising edge of Write Enable. Moreover, for commands that start a modify operation (program/erase) the Write Protect pin must be high. See [Figure 6.2](#) and [Table 5.4](#) for details of the timing requirements.

2.3 Data Input

The Data Input bus operation allows the data to be programmed to be sent to the device. The data insertion is serial and timed by the Write Enable cycles. Data is accepted only with Chip Enable low, Address Latch Enable low, Command Latch Enable low, Read Enable high, and Write Protect high and latched on the rising edge of Write Enable. See [Figure 6.3](#) and [Table 5.4](#) for details of the timings requirements

2.4 Data Output

The Data Output bus operation allows data to be read from the memory array and to check the Status Register content, and the ID data. Data can be serially shifted out by toggling the Read Enable pin with Chip Enable low, Write Enable high, Address Latch Enable low, and Command Latch Enable low. See [Figure 6.4](#) and [Table 5.4](#) for details of the timings requirements.

2.5 Write Protect

The Hardware Write Protection is activated when the Write Protect pin is low. In this condition, modify operations do not start and the content of the memory is not altered. The Write Protect pin is not latched by Write Enable to ensure the protection even during power up.

2.6 Standby

In Standby, the device is deselected, outputs are disabled, and power consumption is reduced.

3. Command Set

Table 3.1 Command Set

Command	1st Cycle	2nd Cycle	3rd Cycle	4th Cycle	Acceptable Command during Busy	
Page Read	00h	30h			No	
Page Program	80h	10h			No	
Random Data Input	85h				No	
Random Data Output	05h	E0h			No	
Page Reprogram	8Bh	10h			No	
Block Erase	60h	D0h			No	
Copy Back Read	00h	35h			No	
Copy Back Program	85h	10h			No	
Special Read For Copy Back	00h	36h			No	
Read Status Register	70h				Yes	
Read Status Enhanced	78h				Yes	
Reset	FFh				Yes	
Read Cache	31h				No	
Read Cache Enhanced	00h	31h			No	
Read Cache End	3Fh				No	
Cache Program (End)	80h	10h			No	
Cache Program (Start) / (Continue)	80h	15h			No	
Read ID	90h				No	
Read ID2	30h-65h-00h	30h			No	
Read ONFI Signature	90h				No	
Read Parameter Page	ECh				No	
Read Unique ID (Contact Factory)	EDh				No	
One-time Programmable (OTP) Area Entry	29h-17h-04h-19h				No	

3.1 Page Read

Page Read is initiated by writing 00h and 30h to the command register along with five address cycles. Two types of operations are available: random read and serial page read. Random read mode is enabled when the page address is changed. All data within the selected page are transferred to the data registers. The system controller may detect the completion of this data transfer (t_R) by analyzing the output of the R/B pin. Once the data in a page is loaded into the data registers, they may be read out in 45 ns cycle time by sequentially pulsing RE#. The repetitive high to low transitions of the RE# signal makes the device output the data, starting from the selected column address up to the last column address.

The device may output random data in a page instead of the sequential data by writing Random Data Output command. The column address of next data, which is going to be out, may be changed to the address that follows Random Data Output command. Random Data Output can be performed as many times as needed.

After power up, the device is in read mode, so 00h command cycle is not necessary to start a read operation. Any operation other than read or Random Data Output causes the device to exit read mode.

See [Figure 6.6](#) and [Figure 6.12](#) as references.

3.2 Page Program

A page program cycle consists of a serial data loading period in which up to 4 KB (x8) of data may be loaded into the data register, followed by a non-volatile programming period where the loaded data is programmed into the appropriate cell.

The serial data loading period begins by inputting the Serial Data Input command (80h), followed by the five cycle address inputs and then serial data. The words other than those to be programmed do not need to be loaded. The device supports Random Data Input within a page. The column address of next data, which will be entered, may be changed to the address that follows the Random Data Input command (85h). Random Data Input may be performed as many times as needed.

The Page Program confirm command (10h) initiates the programming process. The internal write state controller automatically executes the algorithms and controls timings necessary for program and verify, thereby freeing the system controller for other tasks.

Once the program process starts, the Read Status Register commands (70h or 78h) may be issued to read the Status Register. The system controller can detect the completion of a program cycle by monitoring the R/B# output, or the Status bit (I/O6) of the Status Register. Only the Read Status commands (70h or 78h) or Reset command are valid while programming is in progress. When the Page Program is complete, the Write Status Bit (I/O0) may be checked. The internal write verify detects only errors for 1's that are not successfully programmed to 0's. The command register remains in Read Status command mode until another valid command is written to the command register. [Figure 6.9](#) and [Figure 6.11](#) detail the sequence.

The device is programmable by page, but it also allows multiple partial page programming of a word or consecutive bytes up to the full page in a single page program cycle.

The number of consecutive partial page programming operations (NOP) within the same page must not exceed the number indicated in [Table 5.7](#). Pages may be programmed in any order within a block.

If a Page Program operation is interrupted by hardware reset, power failure or other means, the host must ensure that the interrupted page is not used for further reading or programming operations until the next uninterrupted block erase is complete.

3.4 Page Reprogram

Page Program may result in a fail, which can be detected by Read Status Register. In this event, the host may call Page Reprogram. This command allows the reprogramming of the same pattern of the last (failed) page into another memory location. The command sequence initiates with reprogram setup (8Bh), followed by the five cycle address inputs of the target page. If the target pattern for the destination page is not changed compared to the last page, the program confirm can be issued (10h) without any data input cycle, as described in [Figure 3.1](#).

Figure 3.1 Page Reprogram

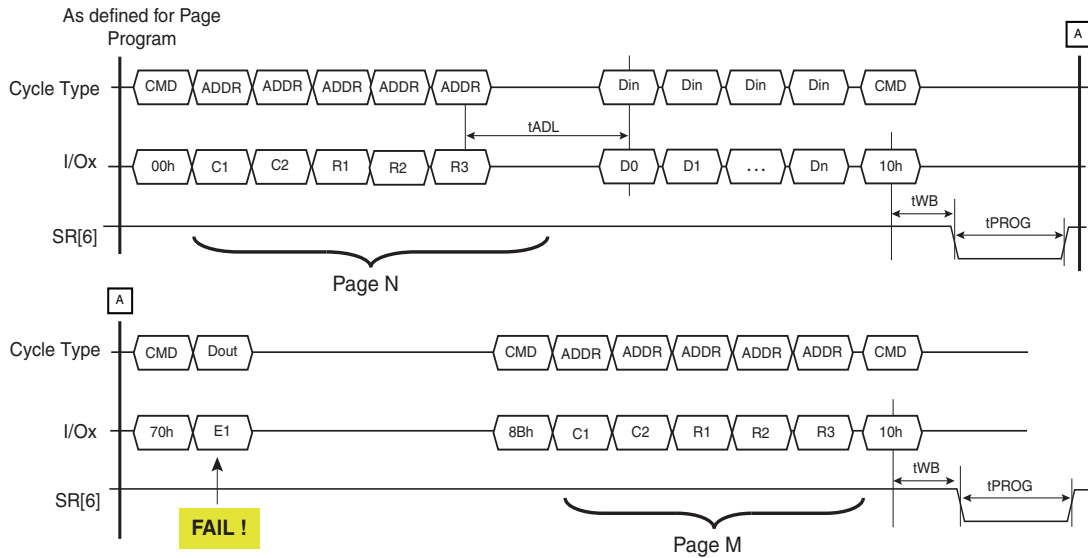

On the other hand, if the pattern bound for the target page is different from that of the previous page, data in cycles can be issued before program confirm '10h', as described in Figure 3.2.

Figure 3.2 Page Reprogram with Data Manipulation

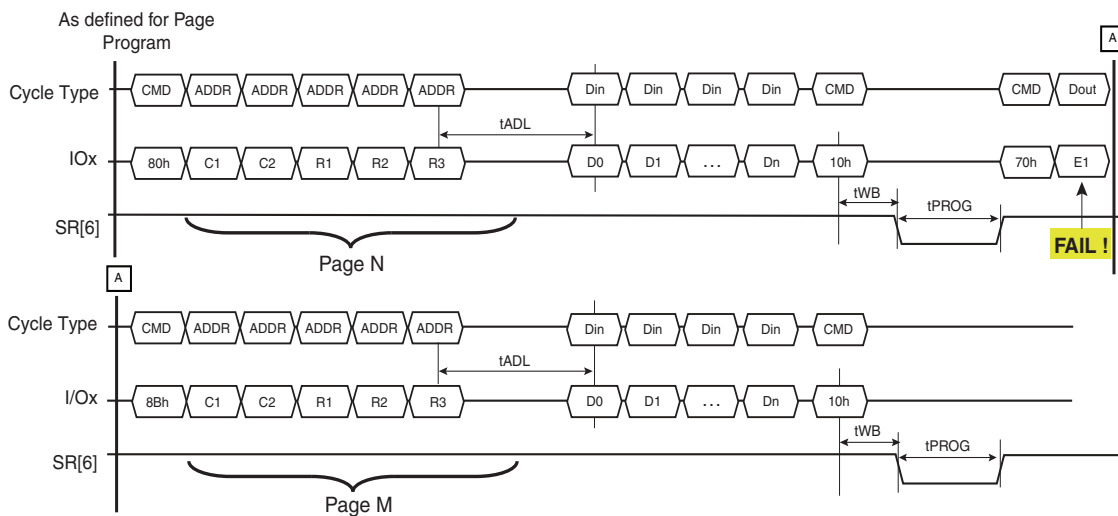

The device supports Random Data Input within a page. The column address of next data, which will be entered, may be changed to the address which follows the Random Data Input command (85h). Random Data Input may be operated multiple times regardless of how many times it is done in a page.

The Program Confirm command (10h) initiates the re-programming process. The internal write state controller automatically executes the algorithms and controls timings necessary for program and verify, thereby freeing the system controller for other tasks. Once the program process starts, the Read Status Register command may be issued to read the Status Register. The system controller can detect the completion of a program cycle by monitoring the R/B# output, or the Status bit (I/O6) of the Status Register. Only the Read Status command and Reset command are valid when programming is in progress. When the Page Program is complete, the Write Status Bit (I/O0) may be checked. The internal write verify detects only errors for 1's that are not successfully programmed to 0's. The command register remains in Read Status command mode until another valid command is written to the command register.

The Page Reprogram must be issued in the same plane as the Page Program that failed. In order to program the data to a different plane, use the Page Program operation instead.

If a Page Reprogram operation is interrupted by hardware reset, power failure or other means, the host must ensure that the interrupted page is not used for further reading or programming operations until the next uninterrupted block erase is complete.

3.5 Block Erase

The Block Erase operation is done on a block basis. Block address loading is accomplished in three cycles initiated by an Erase Setup command (60h). Only the block address bits are valid while the page address bits are ignored.

The Erase Confirm command (D0h) following the block address loading initiates the internal erasing process. This two-step sequence of setup followed by the execution command ensures that memory contents are not accidentally erased due to external noise conditions.

At the rising edge of WE# after the erase confirm command input, the internal write controller handles erase and erase verify. Once the erase process starts, the Read Status Register commands (70h or 78h) may be issued to read the Status Register.

The system controller can detect the completion of an erase by monitoring the R/B# output, or the Status bit (I/O6) of the Status Register. Only the Read Status commands (70h or 78h) and Reset command are valid while erasing is in progress. When the erase operation is completed, the Write Status Bit (I/O0) may be checked. [Figure 6.13](#) details this sequence.

If a Block Erase operation is interrupted by hardware reset, power failure or other means, the host must ensure that the interrupted block is erased under continuous power conditions before that block can be trusted for further programming and reading operations.

3.6 Copy Back Program

The copy back feature is intended to quickly and efficiently rewrite data stored in one page without utilizing an external memory. Since the time-consuming cycles of serial access and re-loading cycles are removed, the system performance is greatly improved. The benefit is especially obvious when a portion of a block needs to be updated and the rest of the block also needs to be copied to the newly assigned free block. The operation for performing a copy back is a sequential execution of page-read (without mandatory serial access) and Copy Back Program with the address of destination page. A read operation with the '35h' command and the address of the source page moves the whole page of data into the internal data register. As soon as the device returns to the Ready state, optional data read-out is allowed by toggling RE# (see [Figure 6.14](#)), or the Copy Back Program command (85h) with the address cycles of the destination page may be written. The Program Confirm command (10h) is required to actually begin programming.

Copy Back Read and Copy Back Program for a given plane must be between odd address pages or between even address pages for the device to meet the program time (t_{PROG}) specification. Copy Back Program may not meet this specification when copying from an odd address page (source page) to an even address page (target page) or from an even address page (source page) to an odd address page (target page).

The data input cycle for modifying a portion or multiple distinct portions of the source page is allowed as shown in [Figure 6.15](#).

If a Copy Back Program operation is interrupted by hardware reset, power failure or other means, the host must ensure that the interrupted page is not used for further reading or programming operations until the next uninterrupted block erase is complete.

3.6.2 Special Read for Copy Back

The S34MS04G2 device supports Special Read for Copy Back. If Copy Back Read is triggered with confirm command '36h' instead '35h', Copy Back Read from target page(s) will be executed with an increased internal (V_{PASS}) voltage.

This special feature is used in order to minimize the number of read errors due to over-program or read disturb — it shall be used only if ECC read errors have occurred in the source page using Page Read or Copy Back Read sequences.

3.7 Read Status Register

The Status Register is used to retrieve the status value for the last operation issued. After writing 70h command to the command register, a read cycle outputs the content of the Status Register to the I/O pins on the falling edge of CE# or RE#, whichever occurs last. This two-line control allows the system to poll the progress of each device in multiple memory connections even when R/B# pins are common-wired. Refer to [Table 3.2](#) “Status Register Coding” for specific Status Register definition, and to [Figure 6.16](#) for timings.

In other words, the Status Register is dynamic; the user is not required to toggle RE# / CE# to update it.

The command register remains in Status Read mode until further commands are issued. Therefore, if the Status Register is read during a random read cycle, the read command (00h) must be issued before starting read cycles.

Note: The Read Status Register command shall not be used for concurrent operations in multi-die stack configurations (single CE#). “Read Status Enhanced” shall be used instead.

3.8 Read Status Enhanced

Read Status Enhanced is used to retrieve the status value for a previous operation in the specified plane.

[Figure 6.17](#) defines the Read Status Enhanced behavior and timings. The plane and die address must be specified in the command sequence in order to retrieve the status of the die and the plane of interest.

Refer to [Table 3.2](#) for specific Status Register definitions. The command register remains in Status Read mode until further commands are issued.

The Status Register is dynamic; the user is not required to toggle RE# / CE# to update it.

3.9 Read Status Register Field Definition

[Table 3.2](#) below lists the meaning of each bit of the Read Status Register and Read Status Enhanced.

Table 3.2 Status Register Coding

ID	Page Program / Page Reprogram	Block Erase	Read	Read Cache	Cache Program / Cache Reprogram	Coding
0	Pass / Fail	Pass / Fail	NA	NA	Pass / Fail	N Page Pass: 0 Fail: 1
1	NA	NA	NA	NA	Pass / Fail	N - 1 Page Pass: 0 Fail: 1
2	NA	NA	NA	NA	NA	—
3	NA	NA	NA	NA	NA	—
4	NA	NA	NA	NA	NA	—
5	Ready / Busy	Ready / Busy	Ready / Busy	Ready / Busy	Ready / Busy	Internal Data Operation Active: 0 Idle: 1
6	Ready / Busy	Ready / Busy	Ready / Busy	Ready / Busy	Ready / Busy	Ready / Busy Busy: 0 Ready: 1
7	Write Protect	Write Protect	NA	NA	Write Protect	Protected: 0 Not Protected: 1

3.10 Reset

The Reset feature is executed by writing FFh to the command register. If the device is in the Busy state during random read, program, or erase mode, the Reset operation will abort these operations. The contents of memory cells being altered are no longer valid, as the data may be partially programmed or erased. The command register is cleared to wait for the next command, and the Status Register is cleared to value E0h when WP# is high or value 60h when WP# is low. If the device is already in reset state a new Reset command will not be accepted by the command register. The R/B# pin transitions to low for t_{RST} after the Reset command is written. Refer to [Figure 6.18](#) for further details. The Status Register can also be read to determine the status of a Reset operation.

3.11 Read Cache

Read Cache can be used to increase the read operation speed, as defined in “Page Read” on page 12, and it cannot cross a block boundary. As soon as the user starts to read one page, the device automatically loads the next page into the cache register. Serial data output may be executed while data in the memory is read into the cache register. Read Cache is initiated by the Page Read sequence (00-30h) on a page M.

After random access to the first page is complete (R/B# returned to high, or Read Status Register I/O6 switches to high), two command sequences can be used to continue read cache:

- Read Cache (command ‘31h’ only): once the command is latched into the command register (see [Figure 6.20](#)), device goes busy for a short time (t_{CBSYR}), during which data of the first page is transferred from the data register to the cache register. At the end of this phase, the cache register data can be output by toggling RE# while the next page (page address M+1) is read from the memory array into the data register.
- Read Cache Enhanced (sequence ‘00h’ <page N address> ‘31’): once the command is latched into the command register (see [Figure 6.21](#)), device goes busy for a short time (t_{CBSYR}), during which data of the first page is transferred from the data register to the cache register. At the end of this phase, cache register data can be output by toggling RE# while page N is read from the memory array into the data register.

Subsequent pages are read by issuing additional Read Cache or Read Cache Enhanced command sequences. If serial data output time of one page exceeds random access time (t_R), the random access time of the next page is hidden by data downloading of the previous page.

On the other hand, if 31h is issued prior to completing the random access to the next page, the device will stay busy as long as needed to complete random access to this page, transfer its contents into the cache register, and trigger the random access to the following page.

To terminate the Read Cache operation, 3Fh command should be issued (see [Figure 6.22](#)). This command transfers data from the data register to the cache register without issuing next page read.

During the Read Cache operation, the device doesn't allow any other command except for 00h, 31h, 3Fh, Read SR, or Reset (FFh). To carry out other operations, Read Cache must be terminated by the Read Cache End command (3Fh) or the device must be reset by issuing FFh.

Read Status command (70h) may be issued to check the status of the different registers and the busy/ready status of the cached read operations.

- The Cache-Busy status bit I/O6 indicates when the cache register is ready to output new data.
- The status bit I/O5 can be used to determine when the cell reading of the current data register contents is complete.

Note: The Read Cache and Read Cache End commands reset the column counter, thus, when RE# is toggled to output the data of a given page, the first output data is related to the first byte of the page (column address 00h). Random Data Output command can be used to switch column address.

3.12 Cache Program

Cache Program can improve the program throughput by using the cache register. The Cache Program operation cannot cross a block boundary. The cache register allows new data to be input while the previous data that was transferred to the data register is programmed into the memory array.

After the serial data input command (80h) is loaded to the command register, followed by five cycles of address, a full or partial page of data is latched into the cache register.

Once the cache write command (15h) is loaded to the command register, the data in the cache register is transferred into the data register for cell programming. At this time the device remains in the Busy state for a short time (t_{CBSYW}). After all data of the cache register is transferred into the data register, the device returns to the Ready state and allows loading the next data into the cache register through another Cache Program command sequence (80h-15h).

The Busy time following the first sequence 80h - 15h equals the time needed to transfer the data from the cache register to the data register. Cell programming the data of the data register and loading of the next data into the cache register is consequently processed through a pipeline model.

In case of any subsequent sequence 80h - 15h, transfer from the cache register to the data register is held off until cell programming of current data register contents is complete; till this moment the device will stay in a busy state (t_{CBSYW}).

Read Status commands (70h or 78h) may be issued to check the status of the different registers, and the pass/fail status of the cached program operations.

- The Cache-Busy status bit I/O6 indicates when the cache register is ready to accept new data.
- The status bit I/O5 can be used to determine when the cell programming of the current data register contents is complete.
- The Cache Program error bit I/O1 can be used to identify if the previous page (page N-1) has been successfully programmed or not in a Cache Program operation. The status bit is valid upon I/O6 status bit changing to 1.
- The error bit I/O0 is used to identify if any error has been detected by the program/erase controller while programming page N. The status bit is valid upon I/O5 status bit changing to 1.

I/O1 may be read together with I/O0.

If the system monitors the progress of the operation only with R/B#, the last page of the target program sequence must be programmed with Page Program Confirm command (10h). If the Cache Program command (15h) is used instead, the status bit I/O5 must be polled to find out if the last programming is finished before starting any other operation. See [Table 3.2](#) and [Figure 6.23](#) for more details.

If a Cache Program operation is interrupted by hardware reset, power failure or other means, the host must ensure that the interrupted pages are not used for further reading or programming operations until the next uninterrupted block erases are complete for the applicable blocks.

3.13 Read ID

The device contains a product identification mode, initiated by writing 90h to the command register, followed by an address input of 00h.

Note: If you want to execute Read Status command (0x70) after Read ID sequence, you should input dummy command (0x00) before Read Status command (0x70).

For the S34MS04G2 device, five read cycles sequentially output the manufacturer code (01h), and the device code and 3rd, 4th, and 5th cycle ID, respectively. The command register remains in Read ID mode until further commands are issued to it.

Table 3.3 to Table 3.7 explain the byte meaning.

Table 3.3 Read ID for Supported Configurations

Density	Org	V _{CC}	1st	2nd	3rd	4th	5th
16 Gb (4Gbx4 - QDP with one CE# -4K page)	x8	1.8V	01h	A5h	C2h	26h	6Ah

3rd ID Data

Table 3.5 Read ID Byte 3 Description

	Description	I/O7	I/O6	I/O5 I/O4	I/O3 I/O2	I/O1 I/O0
Internal Chip Number	1					0 0
	2					0 1
	4					1 0
	8					1 1
Cell type	2-level cell				0 0	
	4-level cell				0 1	
	8-level cell				1 0	
	16-level cell				1 1	
Number of simultaneously programmed pages	1			0 0		
	2			0 1		
	4			1 0		
	8			1 1		
Interleave program Between multiple chips	Not supported		0			
	Supported		1			
Cache Program	Not supported	0				
	Supported	1				

4th ID Data
Table 3.6 Read ID Byte 4 Description

	Description	I/O7	I/O6	I/O5 I/O4	I/O3	I/O2	I/O1 I/O0
Page Size (without spare area)	4 KB						1 0
Block Size (without spare area)	256 KB			10			
Spare Area Size (byte / 512 byte)	32					1	
Serial Access Time	45 ns	0			0		
Organization	x8		0				

5th ID Data
Table 3.7 Read ID Byte 5 Description

	Description	I/O7	I/O6 I/O5 I/O4	I/O3 I/O2	I/O1 I/O0
ECC Level	4 bit / 512 bytes				1 0
Plane Number	16Gb)			10	
Plane Size (without spare area)	4Gb/ 8Gb/16Gb		11 0		
Reserved		0			

3.14 Read ID2

The device contains an alternate identification mode, initiated by writing 30h-65h-00h to the command register, followed by address inputs, followed by command 30h. The address for S34MS04G2 will be 00h-02h-02h-00h-00h. The ID2 data can then be read from the device by pulsing RE#. The command register remains in Read ID2 mode until further commands are issued to it.

[Figure 6.25](#) shows the Read ID2 command sequence. Read ID2 values are all 0xFs, unless specific values are requested when ordering from SkyHigh.

3.15 Read ONFI Signature

To retrieve the ONFI signature, the command 90h together with an address of 20h shall be entered (i.e. it is not valid to enter an address of 00h and read 36 bytes to get the ONFI signature). The ONFI signature is the ASCII encoding of 'ONFI' where 'O' = 4Fh, 'N' = 4Eh, 'F' = 46h, and 'I' = 49h. Reading beyond four bytes yields indeterminate values. [Figure 6.26](#) shows the operation sequence.

3.16 Read Parameter Page

The device supports the ONFI Read Parameter Page operation, initiated by writing ECh to the command register, followed by an address input of 00h. The host may monitor the R/B# pin or wait for the maximum data transfer time (t_R) before reading the Parameter Page data. The command register remains in Parameter Page mode until further commands are issued to it. If the Status Register is read to determine when the data is ready, the Read Command (00h) must be issued before starting read cycles.

Figure 6.27 shows the operation sequence, while Table 3.8 explains the parameter fields.

Note: For 32nm SkyHigh NAND, for a particular condition, the Read Parameter Page command does not give the correct values. To overcome this issue, the host must issue a Reset command before the Read Parameter Page command. Issuance of Reset before the Read Parameter Page command will provide the correct values and will not output 00h values.

Table 3.8 Parameter Page Description (S34MS16G2)

Byte	O/M	Description	Values
Revision Information and Features Block			
0-3	M	Parameter page signature Byte 0: 4Fh, "O" Byte 1: 4Eh, "N" Byte 2: 46h, "F" Byte 3: 49h, "I"	4Fh, 4Eh, 46h, 49h
4-5	M	Revision number 2-15 Reserved (0) 1 1 = supports ONFI version 1.0 0 Reserved (0)	02h, 00h
6-7	M	Features supported 5-15 Reserved (0) 4 1 = supports odd to even page Copyback 3 1 = supports interleaved operations 2 1 = supports non-sequential page programming 1 1 = supports multiple LUN operations 0 1 = supports 16-bit data bus width	10h, 00h
8-9	M	Optional commands supported 6-15 Reserved (0) 5 1 = supports Read Unique ID 4 1 = supports Copyback 3 1 = supports Read Status Enhanced 2 1 = supports Get Features and Set Features 1 1 = supports Read Cache commands 0 1 = supports Page Cache Program command	3Bh, 00h
10-31		Reserved (0)	00h
Manufacturer Information Block			
32-43	M	Device manufacturer (12 ASCII characters)	53h, 50h, 41h, 4Eh, 53h, 49h, 4Fh, 4Eh, 20h, 20h, 20h, 20h
44-63	M	Device model (20 ASCII characters)	53h, 33h, 34h, 4Dh, 53h, 31h, 36h, 47h, 32h, 20h, 20h, 20h, 20h, 20h, 20h, 20h, 20h, 20h, 20h, 20h, 20h
64	M	JEDEC manufacturer ID	01h
65-66	O	Date code	00h
67-79		Reserved (0)	00h
Memory Organization Block			
80-83	M	Number of data bytes per page	00h, 10h, 00h, 00h
84-85	M	Number of spare bytes per page	00h, 01h
86-89	M	Number of data bytes per partial page	00h, 00h, 00h, 00h
90-91	M	Number of spare bytes per partial page	00h, 00h

Table 3.9 Parameter Page Description (Continued)

Byte	O/M	Description	Values
92-95	M	Number of pages per block	40h, 00h, 00h, 00h
96-99	M	Number of blocks per logical unit (LUN)	00h, 20h, 00h, 00h (1 CE#)
100	M	Number of logical units (LUNs)	01h (1 CE#)
101	M	Number of address cycles 4-7 Column address cycles 0-3 Row address cycles	23h
102	M	Number of bits per cell	01h
103-104	M	Bad blocks maximum per LUN	A3h, 00h (1 CE#)
105-106	M	Block endurance	01h, 05h
107	M	Guaranteed valid blocks at beginning of target	01h
108-109	M	Block endurance for guaranteed valid blocks	01h, 03h
110	M	Number of programs per page	04h
111	M	Partial programming attributes 5-7 Reserved 4 1 = partial page layout is partial page data followed by partial page spare 1-3 Reserved 0 1 = partial page programming has constraints	00h
112	M	Number of bits ECC correctability	04h
113	M	Number of interleaved address bits 4-7 Reserved (0) 0-3 Number of interleaved address bits	01h
114	O	Interleaved operation attributes 4-7 Reserved (0) 3 Address restrictions for program cache 2 1 = program cache supported 1 1 = no block address restrictions 0 Overlapped / concurrent interleaving support	04h
115-127		Reserved (0)	00h
Electrical Parameters Block			
128	M	I/O pin capacitance	0Ah
129-130	M	Timing mode support 6-15 Reserved (0) 5 1 = supports timing mode 5 4 1 = supports timing mode 4 3 1 = supports timing mode 3 2 1 = supports timing mode 2 1 1 = supports timing mode 1 0 1 = supports timing mode 0, shall be 1	07h, 00h
131-132	O	Program cache timing mode support 6-15 Reserved (0) 5 1 = supports timing mode 5 4 1 = supports timing mode 4 3 1 = supports timing mode 3 2 1 = supports timing mode 2 1 1 = supports timing mode 1 0 1 = supports timing mode 0	07h, 00h
133-134	M	t _{PROG} Maximum page program time (μs)	BCh, 02h

Table 3.9 Parameter Page Description (Continued)

Byte	O/M	Description	Values
135-136	M	t _{BERS} Maximum block erase time (μs)	10h, 27h
137-138	M	t _R Maximum page read time (μs)	1Eh, 00h
139-140	M	t _{CCS} Minimum Change Column setup time (ns)	C8h, 00h
141-163		Reserved (0)	00h
Vendor Block			
164-165	M	Vendor specific Revision number	00h
166-253		Vendor specific	00h
254-255	M	Integrity CRC	70h, CEh
Redundant Parameter Pages			
256-511	M	Value of bytes 0-255	Repeat Value of bytes 0-255
512-767	M	Value of bytes 0-255	Repeat Value of bytes 0-255
768+	O	Additional redundant parameter pages	FFh

Note:

1. "O" Stands for Optional, "M" for Mandatory.

3.17 Read Unique ID (Contact Factory)

The device supports the ONFI Read Unique ID function, initiated by writing EDh to the command register, followed by an address input of 00h. The host must monitor the R/B# pin or wait for the maximum data transfer time (t_R) before reading the Unique ID data. The first sixteen bytes returned by the flash is a unique value. The next sixteen bytes returned are the bit-wise complement of the unique value. The host can verify the Unique ID was read correctly by performing an XOR of the two values. The result should be all ones. The command register remains in Unique ID mode until further commands are issued to it. [Figure 6.28](#) shows the operation sequence, while [Table 3.9](#) shows the Unique ID data contents. SkyHigh guarantees unique id support feature with a special model number shown in the OPN combination in "Ordering Information".

Note: For 32nm SkyHigh NAND, for a particular condition, the Read Unique ID command does not give the correct values. To overcome this issue, the host must issue a Reset command before the Read Unique ID command. Issuance of Reset before the Read Unique ID command will provide the correct values and will not output 00h values.

Table 3.9 Unique ID Data Description (Contact Factory)

Byte	Description
0-15	Unique ID
16-31	ID Complement
32-47	Unique ID
48-63	ID Complement
64-79	Unique ID
80-95	ID Complement
96-111	Unique ID
112-127	ID Complement
128-143	Unique ID
144-159	ID Complement
160-175	Unique ID
176-191	ID Complement
192-207	Unique ID
208-223	ID Complement
224-239	Unique ID

Table 3.9 Unique ID Data Description (Contact Factory) (Continued)

Byte	Description
240-255	ID Complement
256-271	Unique ID
272-287	ID Complement
288-303	Unique ID
304-319	ID Complement
320-335	Unique ID
336-351	ID Complement
352-367	Unique ID
368-383	ID Complement
384-399	Unique ID
400-415	ID Complement
416-431	Unique ID
432-447	ID Complement
448-463	Unique ID
464-479	ID Complement
480-495	Unique ID
496-511	ID Complement

3.18 One-Time Programmable (OTP) Entry

The device contains a one-time programmable (OTP) area, which is accessed by writing 29h-17h-04h-19h to the command register. The device is then ready to accept Page Read and Page Program commands (refer to [Page Read](#) and ["Page Program"](#)). The OTP area is of a single erase block size (64 pages), and hence only row addresses between 00h and 3Fh are allowed. The host must issue the Reset command (refer to ["Reset"](#)) to exit the OTP area and access the normal flash array. The BlockErase command is not allowed in the OTP area. Refer to [Figure 6.29](#) for more detail on the OTP Entry command sequence.

4. Signal Descriptions

4.1 Data Protection and Power On / Off Sequence

The device is designed to offer protection from any involuntary program/erase during power-transitions. An internal voltage detector disables all functions whenever V_{CC} is below about 1.1V.

The power-up and power-down sequence is shown in Figure 6.30, in this case V_{CC} and V_{CCQ} on the one hand (and V_{SS} and V_{SSQ} on the other hand) are shorted together at all times.

The Ready/Busy signal shall be valid within 100 μ s after the power supplies have reached the minimum values (as specified on), and shall return to one within 5 ms (max).

During this busy time, the device executes the initialization process (cam reading), and dissipates a current I_{CC0} (30 mA max), in addition, it disregards all commands excluding Read Status Register (70h).

At the end of this busy time, the device defaults into "read setup", thus if the user decides to issue a page read command, the 00h command may be skipped.

The WP# pin provides hardware protection and is recommended to be kept at V_{IL} during power-up and power-down. A recovery time of minimum 100 μ s is required before the internal circuit gets ready for any command sequences as shown in Figure 6.30. The two-step command sequence for program/erase provides additional software protection.

4.2 Ready/Busy

The Ready/Busy output provides a method of indicating the completion of a page program, erase, copyback, or read completion. The R/B# pin is normally high and goes to low when the device is busy (after a reset, read, program, or erase operation). It returns to high when the internal controller has finished the operation. The pin is an open-drain driver thereby allowing two or more R/B# outputs to be Or-tied. Because the pull-up resistor value is related to t_r (R/B#) and the current drain during busy (i_{busy}), and output load capacitance is related to t_f , an appropriate value can be obtained with the reference chart shown in Figure 4.1.

Figure 4.1 Ready/Busy Pin Electrical Application

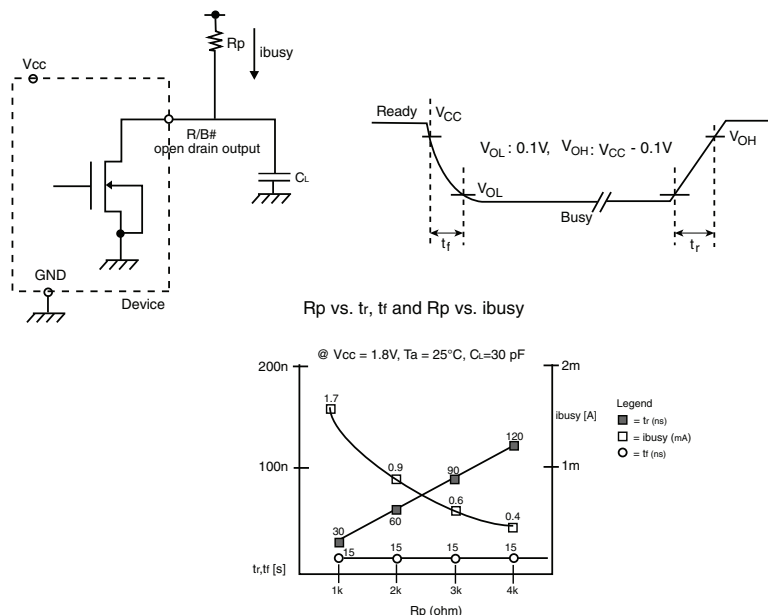

Rp value guidance

$$R_p(\text{min.}) = \frac{V_{CC}(\text{Max.}) - V_{OL}(\text{Max.})}{I_{OL} + \sum I_L} = \frac{1.85V}{3mA + \sum I_L}$$

where I_L is the sum of the input currents of all devices tied to the R/B# pin.
 $R_p(\text{max})$ is determined by maximum permissible limit of t_r .

4.3 Write Protect Operation

Erase and program operations are aborted if WP# is driven low during busy time, and kept low for about 100 ns. Switching WP# low during this time is equivalent to issuing a Reset command (FFh). The contents of memory cells being altered are no longer valid, as the data will be partially programmed or erased. The R/B# pin will stay low for t_{RST} (similarly to Figure 6.18). At the end of this time, the command register is ready to process the next command, and the Status Register bit I/O6 will be cleared to 1, while I/O7 value will be related to the WP# value. Refer to Table 3.2 for more information on device status.

Erase and program operations are enabled or disabled by setting WP# to high or low respectively, prior to issuing the setup commands (80h or 60h). The level of WP# shall be set t_{WV} ns prior to raising the WE# pin for the set up command, as explained in Figure 6.31 and Figure 6.32.

Figure 4.2 WP# Low Timing Requirements during Program/Erase Command Sequence

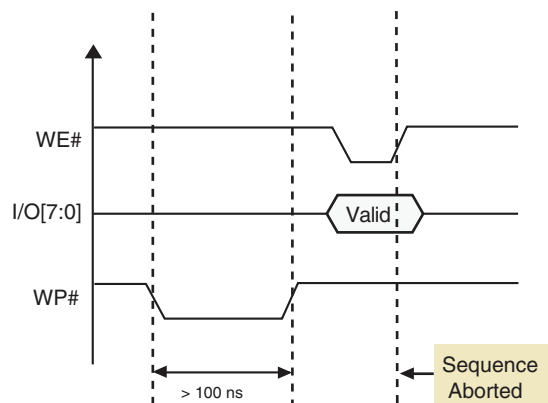

5. Electrical Characteristics

5.1 Valid Blocks

Table 5.1 Valid Blocks

Device	Symbol	Min	Typ	Max	Unit
S34MS16G2	N_{VB}	8029	—	8192	Blocks

5.2 Absolute Maximum Ratings

Table 5.2 Absolute Maximum Ratings

Parameter	Symbol	Value	Unit
Ambient Operating Temperature (Industrial Temperature Range)	T_A	-40 to +85	°C
Ambient Operating Temperature (Industrial Plus Temperature Range)	T_A	-40 to +105	°C
Temperature under Bias	T_{BIAS}	-50 to +125	°C
Storage Temperature	T_{STG}	-65 to +150	°C
Input or Output Voltage	$V_{IO(2)}$	-0.6 to +2.7	V
Supply Voltage	V_{CC}	-0.6 to +2.7	V

Notes:

1. Except for the rating "Operating Temperature Range", stresses above those listed in the table [Absolute Maximum Ratings](#) may cause permanent damage to the device. These are stress ratings only and operation of the device at these or any other conditions above those indicated in the Operating sections of this specification is not implied. Exposure to Absolute Maximum Rating conditions for extended periods may affect device reliability.
2. Minimum Voltage may undershoot to -2V during transition and for less than 20 ns during transitions.
3. Maximum Voltage may overshoot to $V_{CC} + 2.0V$ during transition and for less than 20 ns during transitions.

5.3 AC Test Conditions

Table 5.3 AC Test Conditions

Parameter	Value
Input Pulse Levels	0.0V to V_{CC}
Input Rise And Fall Times	5 ns
Input And Output Timing Levels	$V_{CC} / 2$
Output Load (1.7V - 1.95V)	1 TTL Gate and $CL = 30$ pF

5.4 AC Characteristics

Table 5.4 AC Characteristics

Parameter	Symbol	Min	Max	Unit
ALE to RE# delay	t_{AR}	10	—	ns
ALE hold time	t_{ALH}	10	—	ns
ALE setup time	t_{ALS}	15	—	ns
Address to data loading time	t_{ADL}	100	—	ns
CE# Access Time	$t_{CEA}^{(4)}$	—	30	ns
CE# low to RE# low	t_{CR}	10	—	ns
CE# hold time	t_{CH}	10	—	ns
CE# high to output High-Z	t_{CHZ}	—	50	ns
CLE hold time	t_{CLH}	10	—	ns
CLE to RE# delay	t_{CLR}	10	—	ns
CLE setup time	t_{CLS}	15	—	ns
CE# high to output hold	$t_{COH}^{(3)}$	15	—	ns
CE# high to ALE or CLE don't care	t_{CSD}	10	—	ns
CE# setup time	t_{CS}	25	—	ns
Data hold time	t_{DH}	5	—	ns
Data setup time	t_{DS}	15	—	ns
Data transfer from cell to register	t_R	—	30	μ s
Output High-Z to RE# low	t_{IR}	0	—	ns
Read cycle time	t_{RC}	35	—	ns
RE# access time	t_{REA}	—	25	ns
RE# high hold time	t_{REH}	15	—	ns
RE# high to output hold	$t_{RHOH}^{(3)}$	15	—	ns
RE# high to WE# low	t_{RHW}	100	—	ns
RE# high to output High-Z	t_{RHZ}	—	100	ns
RE# low to output hold	$t_{RLOH}^{(5)}$	—	—	ns
RE# pulse width	t_{RP}	17	—	ns
Ready to RE# low	t_{RR}	20	—	ns
Device resetting time (Read/Program/Erase)	t_{RST}	—	5/10/500 (2)	μ s
WE# high to busy	t_{WB}	—	100	ns
Write cycle time	t_{WC}	35	—	ns
WE# high hold time	t_{WH}	15	—	ns
WE# high to RE# low	t_{WHR}	80	—	ns
WE# high to RE# low for Random data out	t_{WHR2}	200	—	ns
WE# pulse width	t_{WP}	17	—	ns
Write protect time	t_{WW}	100	—	ns

Notes:

1. The time to Ready depends on the value of the pull-up resistor tied to R/B# pin.
2. If Reset Command (FFh) is written at Ready state, the device goes into Busy for maximum 5 μ s.
3. CE# low to high or RE# low to high can be at different times and produce three cases. Depending on which signal comes high first, either t_{COH} or t_{RHOH} will be met.

4. During data output, t_{CEA} depends partly on t_{CR} (CE# low to RE# low). If t_{CR} exceeds the minimum value specified, then the maximum time for t_{CEA} may also be exceeded ($t_{CEA} = t_{CR} + t_{REA}$).
5. t_{RLOH} is only relevant for EDO timing ($t_{RC} < 30$ ns), which does not apply for this device.

5.5 DC Characteristics

Table 5.5 DC Characteristics and Operating Conditions

Parameter	Symbol	Test Conditions	Min	Typ	Max	Units	
Power-On-Reset Current	I_{CC0}	FFh command input after power on	—	—	50 per device	mA	
Operating Current	Read	I_{CC1} $t_{RC} = t_{RC}(\text{min})$ $CE\# = V_{IL}, I_{OUT} = 0$ mA	—	15	30	mA	
	Program	I_{CC2}	Normal	—	15	30	mA
		Cache	—	—	15	30	mA
Erase	I_{CC3}	—	—	15	30	mA	
Standby Current, (TTL)	I_{CC4}	$CE\# = V_{IH}$, $WP\# = 0V/V_{CC}$	—	—	1	mA	
Standby Current, (CMOS)	I_{CC5}	$CE\# = V_{CC} - 0.2$, $WP\# = 0/V_{CC}$	—	10	50	μ A	
Input Leakage Current	I_{LI}	$V_{IN} = 0$ to $V_{CC}(\text{max})$	—	—	± 10	μ A	
Output Leakage Current	I_{LO}	$V_{OUT} = 0$ to $V_{CC}(\text{max})$	—	—	± 10	μ A	
Input High Voltage	V_{IH}	—	$V_{CC} \times 0.8$	—	$V_{CC} + 0.3$	V	
Input Low Voltage	V_{IL}	—	-0.3	—	$V_{CC} \times 0.2$	V	
Output High Voltage	V_{OH}	$I_{OH} = -100$ μ A	$V_{CC} - 0.1$	—	—	V	
Output Low Voltage	V_{OL}	$I_{OL} = 100$ μ A	—	—	0.1	V	
Output Low Current (R/B#)	$I_{OL(R/B\#)}$	$V_{OL} = 0.1$ V	3	4	—	mA	
Erase and Program Lockout Voltage	V_{LKO}	—	—	1.1	—	V	

Notes:

1. All V_{CC} pins, and V_{SS} pins respectively, are shorted together.
2. Values listed in this table refer to the complete voltage range for V_{CC} and to a single device in case of device stacking.
3. All current measurements are performed with a 0.1 μ F capacitor connected between the V_{CC} Supply Voltage pin and the V_{SS} Ground pin.
4. Standby current measurement can be performed after the device has completed the initialization process at power up. Refer to [Data Protection and Power On / Off Sequence](#) for more details.

5.6 Pin Capacitance

Table 5.6 Pin Capacitance (TA = 25°C, f=1.0 MHz)

Parameter	Symbol	Test Condition	Min	Max	Unit
Input	C _{IN}	V _{IN} = 0V	—	10	pF
Input / Output	C _{IO}	V _{IL} = 0V	—	10	pF

Note:

- For the stacked devices version the Input is 10 pF x [number of stacked chips] and the Input/Output is 10 pF x [number of stacked chips].

5.7 Program / Erase Characteristics

Table 5.7 Program / Erase Characteristics

Parameter	Description	Min	Typ	Max	Unit
Program Time (2)	t _{PROG}	—	300	700	μs
Cache Program short busy time	t _{CBSYW}	—	5	t _{PROG}	μs
Number of partial Program Cycles in the same page	Main + Spare NOP	—	—	4	Cycle
Block Erase Time (t _{BERS}	—	3.5	10	ms
Read Cache busy time	t _{CBSYR}	—	5	t _R	μs

Notes:

- Typical program time is defined as the time within which more than 50% of the whole pages are programmed (V_{CC} = 1.8V, 25°C).
- Copy Back Read and Copy Back Program for a given plane must be between odd address pages or between even address pages for the device to meet the program time (t_{PROG}) specification. Copy Back Program may not meet this specification when copying from an odd address page (source page) to an even address page (target page) or from an even address page (source page) to an odd address page (target page).

6. Timing Diagrams

6.1 Command Latch Cycle

Command Input bus operation is used to give a command to the memory device. Commands are accepted with Chip Enable low, Command Latch Enable High, Address Latch Enable low, and Read Enable High and latched on the rising edge of Write Enable. Moreover for commands that starts a modify operation (write/ erase) the Write Protect pin must be high.

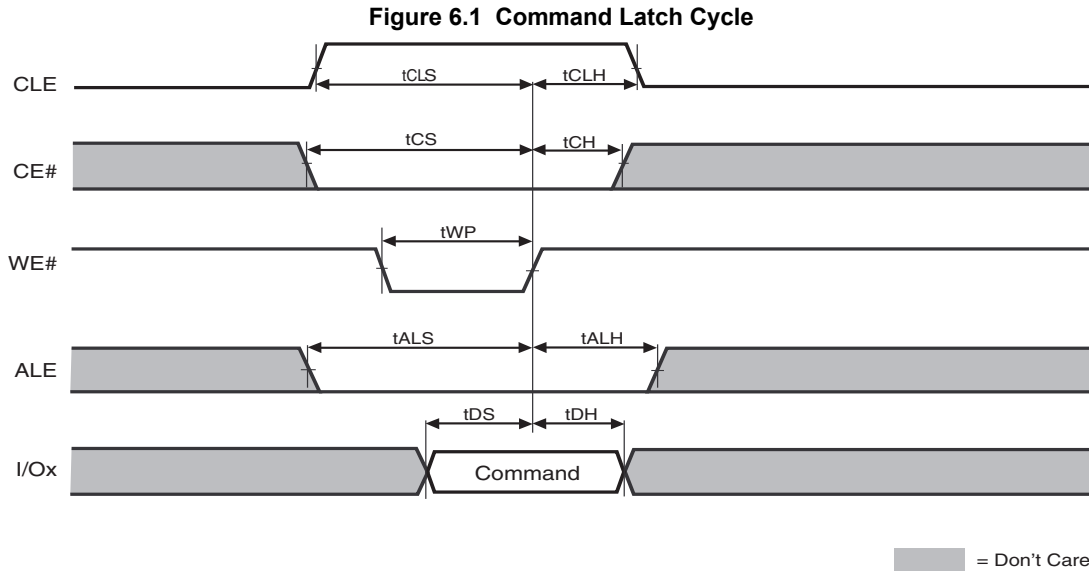

6.2 Address Latch Cycle

Address Input bus operation allows the insertion of the memory address. To insert the 27 (x8 Device) addresses needed to access the 1 Gb, four write cycles are needed. Addresses are accepted with Chip Enable low, Address Latch Enable High, Command Latch Enable low, and Read Enable High and latched on the rising edge of Write Enable. Moreover, for commands that start a modify operation (write/ erase) the Write Protect pin must be high.

Figure 6.2 Address Latch Cycle

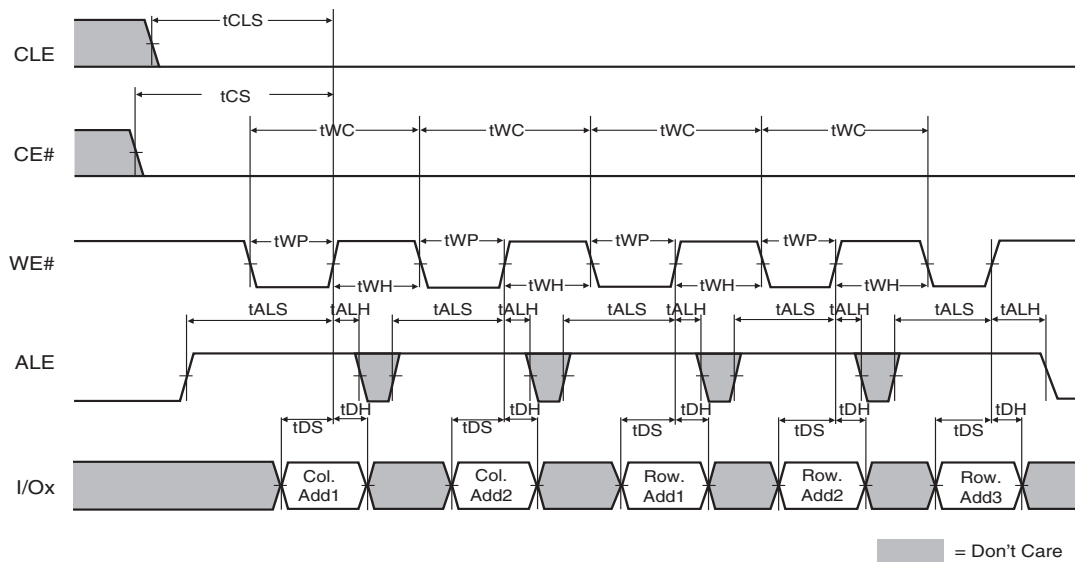

6.3 Data Input Cycle Timing

Data Input bus operation allows the data to be programmed to be sent to the device. The data insertion is serially, and timed by the Write Enable cycles. Data is accepted only with Chip Enable low, Address Latch Enable low, Command Latch Enable low, Read Enable High, and Write Protect High and latched on the rising edge of Write Enable.

Figure 6.3 Input Data Latch Cycle

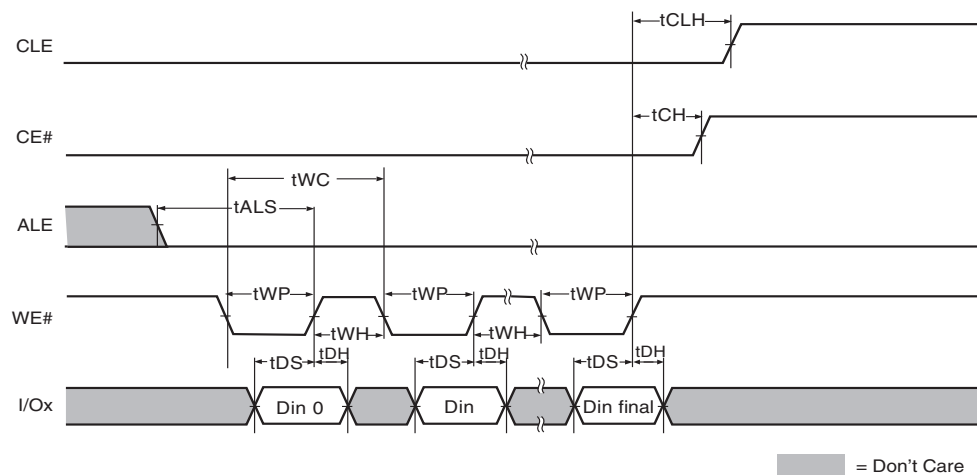

6.4 Data Output Cycle Timing (CLE=L, WE#=H, ALE=L, WP#=H)

Figure 6.4 Data Output Cycle Timing

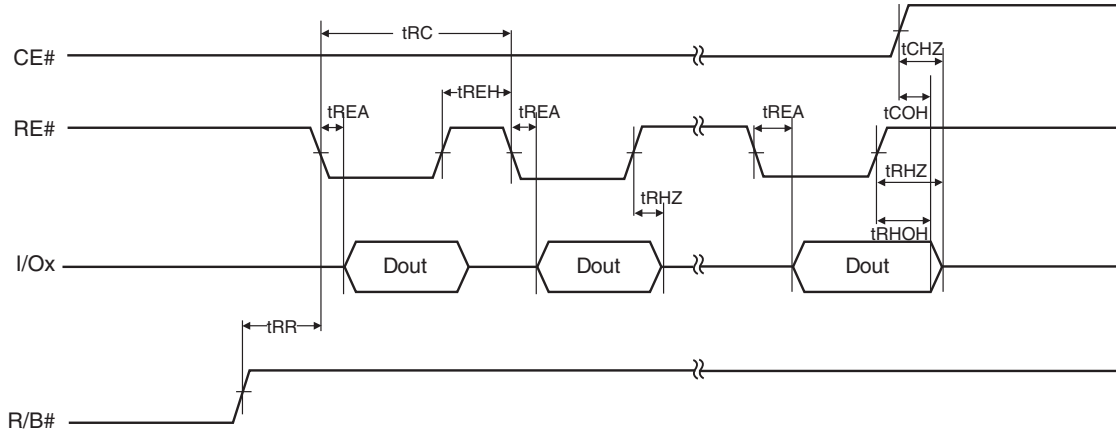

Notes:

1. Transition is measured at ± 200 mV from steady state voltage with load.
2. This parameter is sampled and not 100% tested.
3. t_{RHOH} starts to be valid when frequency is lower than 33 MHz.

6.5 Data Output Cycle Timing (EDO Type, CLE=L, WE#=H, ALE=L)

Figure 6.5 Data Output Cycle Timing (EDO)

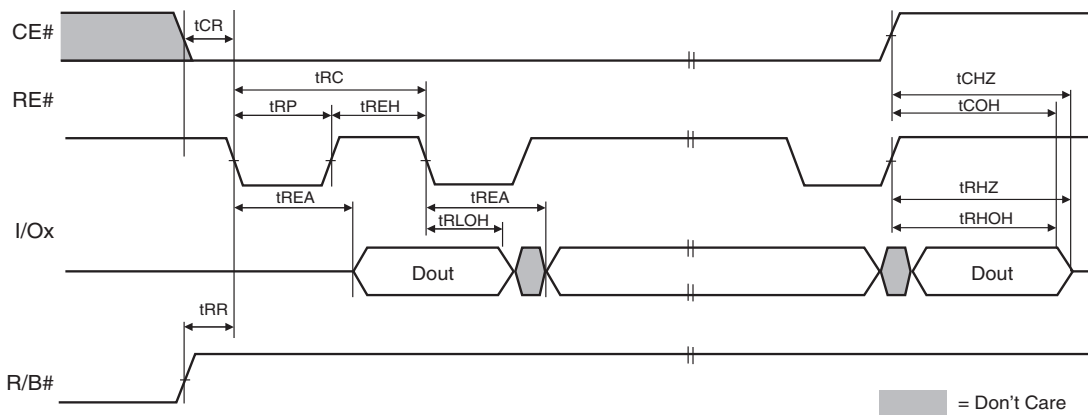

Notes:

1. Transition is measured at ± 200 mV from steady state voltage with load.
2. This parameter is sampled and not 100% tested.
3. t_{RLOH} is valid when frequency is higher than 33 MHz.
4. t_{RHOH} starts to be valid when frequency is lower than 33 MHz.

6.6 Page Read Operation

Figure 6.6 Page Read Operation (Read One Page)

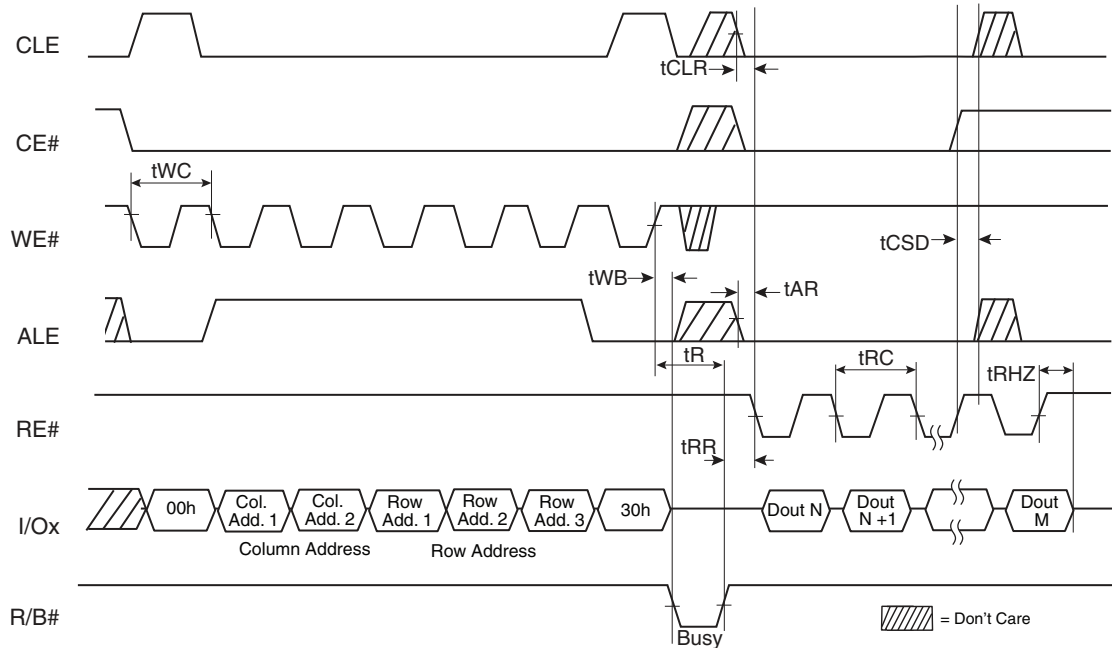

Note:

1. If Status Register polling is used to determine completion of the read operation, the Read Command (00h) must be issued before data can be read from the page buffer.

6.7 Page Read Operation (Interrupted by CE#)

Figure 6.7 Page Read Operation Interrupted by CE#

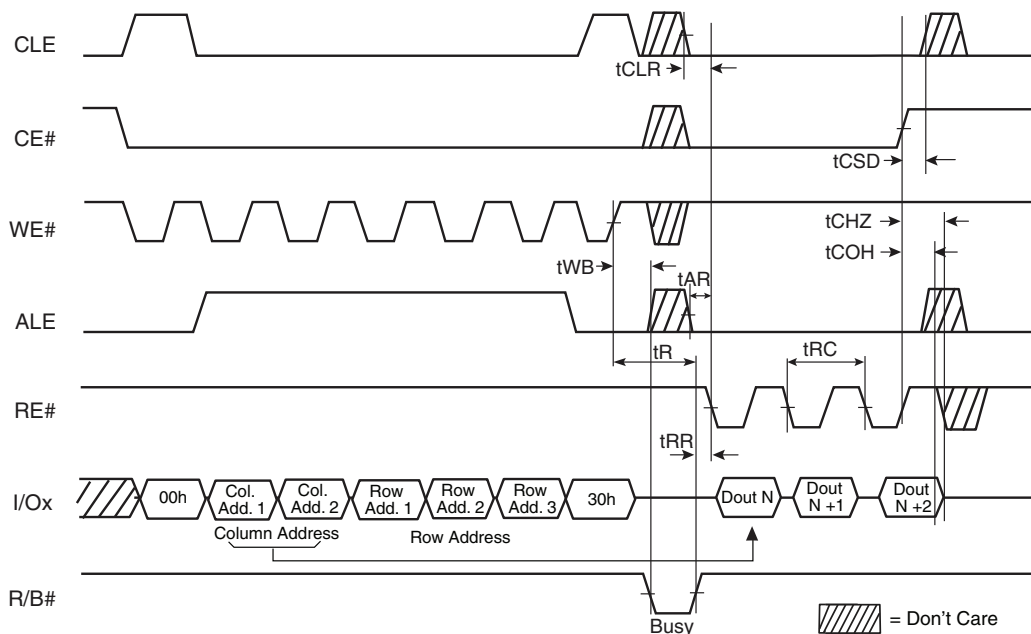

6.8 Page Read Operation Timing with CE# Don't Care

Figure 6.8 Page Read Operation Timing with CE# Don't Care

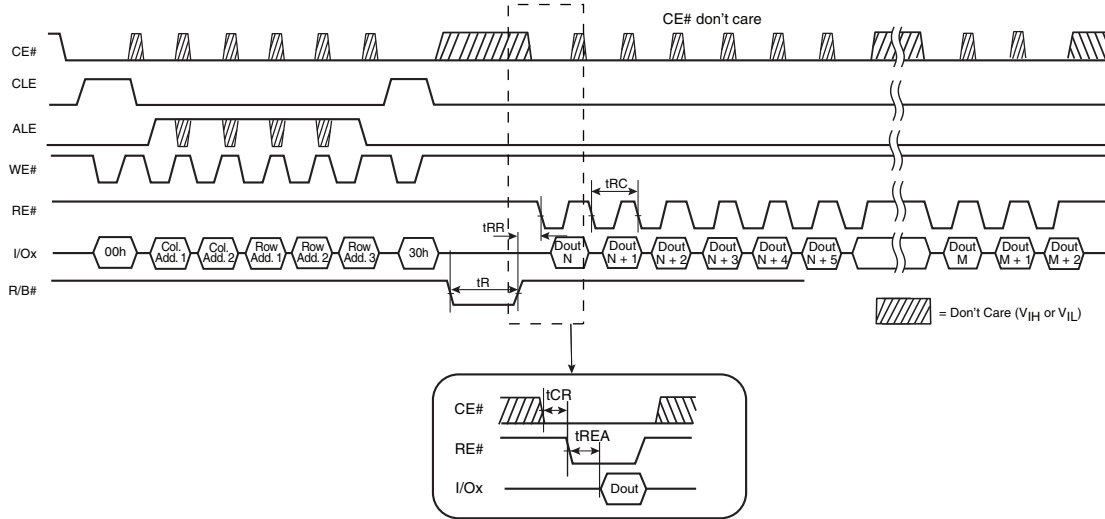

6.9 Page Program Operation

Figure 6.9 Page Program Operation

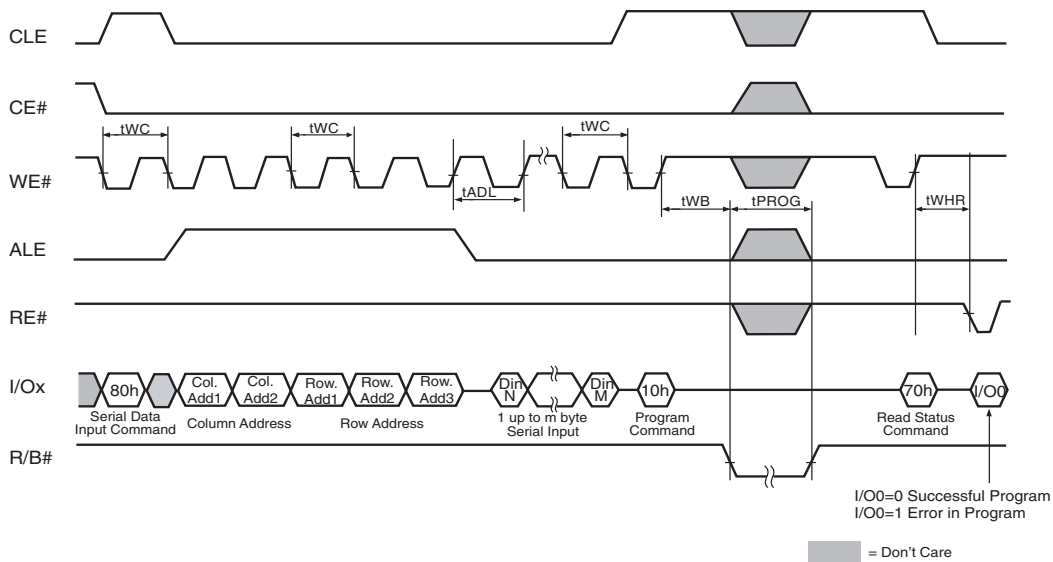

Note:

1. t_{ADL} is the time from the WE# rising edge of final address cycle to the WE# rising edge of first data cycle.

6.10 Page Program Operation Timing with CE# Don't Care

Figure 6.10 Page Program Operation Timing with CE# Don't Care

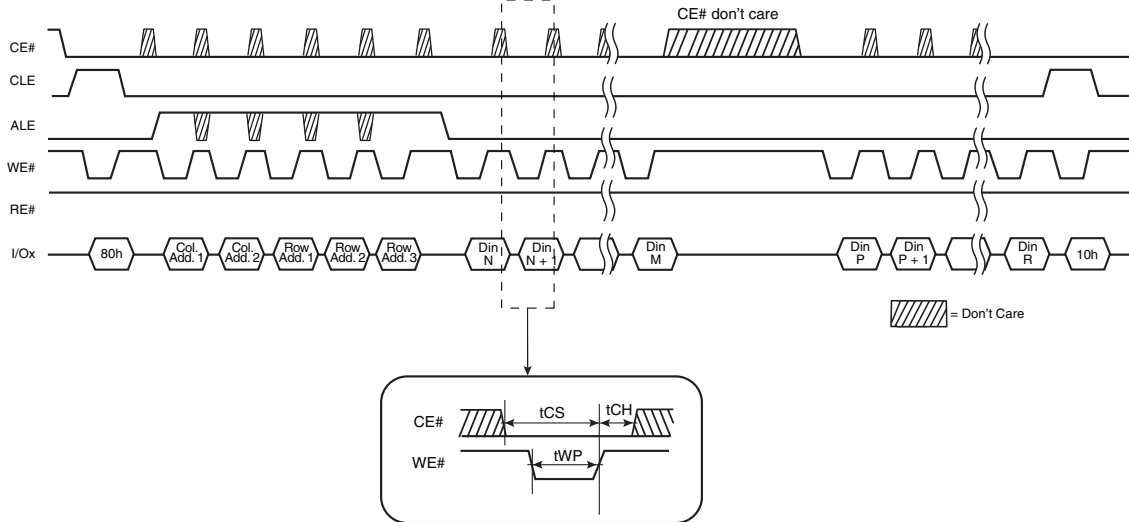

6.11 Page Program Operation with Random Data Input

Figure 6.11 Random Data Input

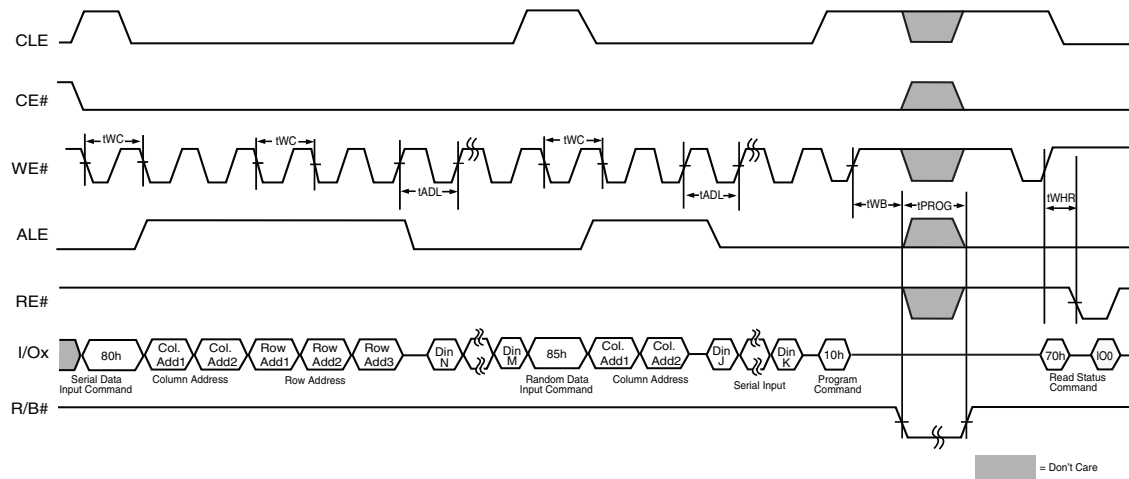

Note:

1. t_{ADL} is the time from the WE# rising edge of final address cycle to the WE# rising edge of first data cycle.

6.12 Random Data Output In a Page

Figure 6.12 Random Data Output

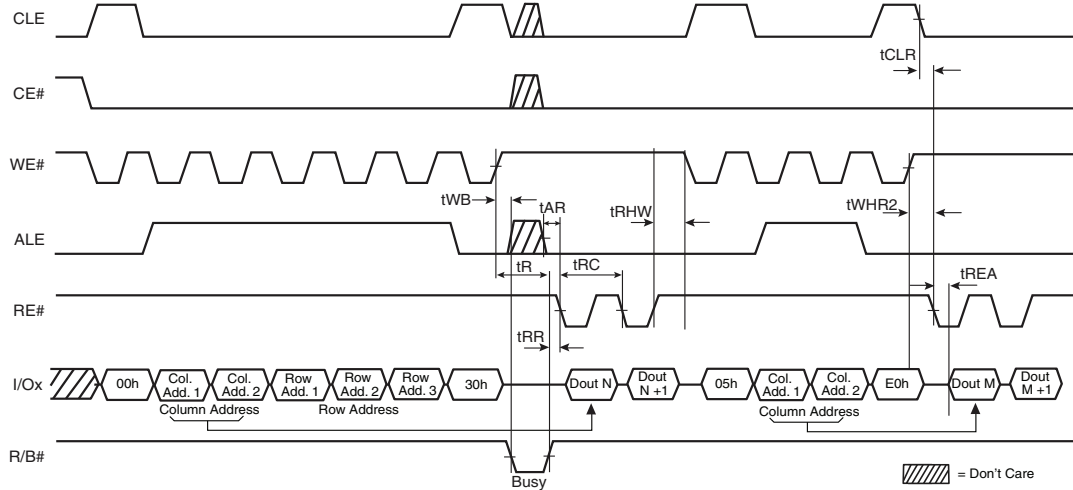

6.13 Block Erase Operation

Figure 6.13 Block Erase Operation (Erase One Block)

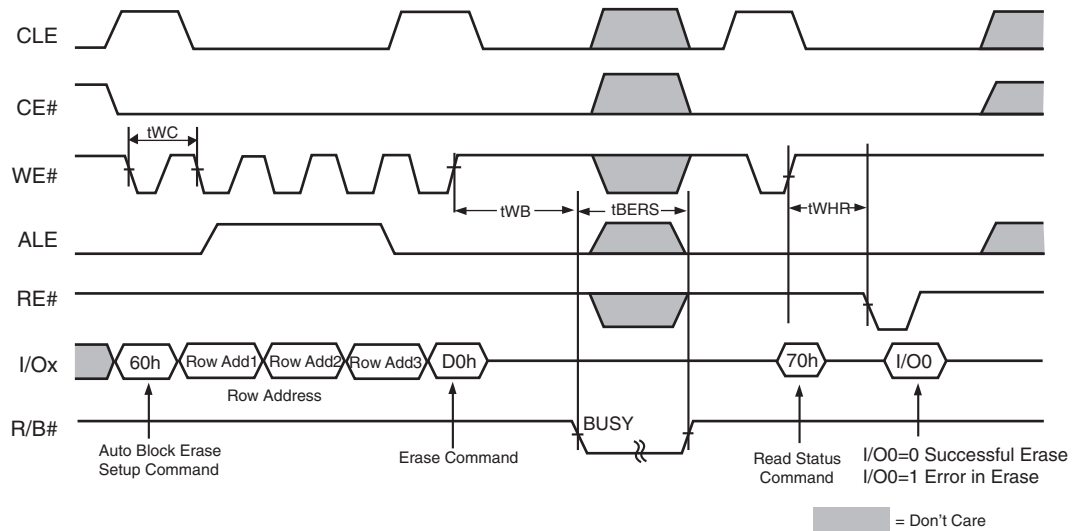

6.14 Copy Back Read with Optional Data Readout

Figure 6.14 Copy Back Read with Optional Data Readout

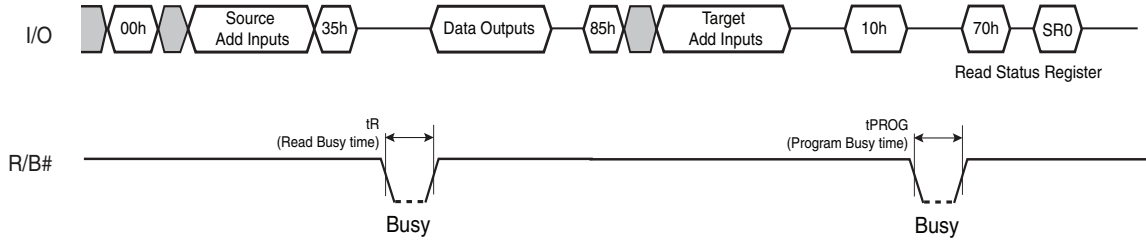

6.15 Copy Back Program Operation With Random Data Input

Figure 6.15 Copy Back Program with Random Data Input

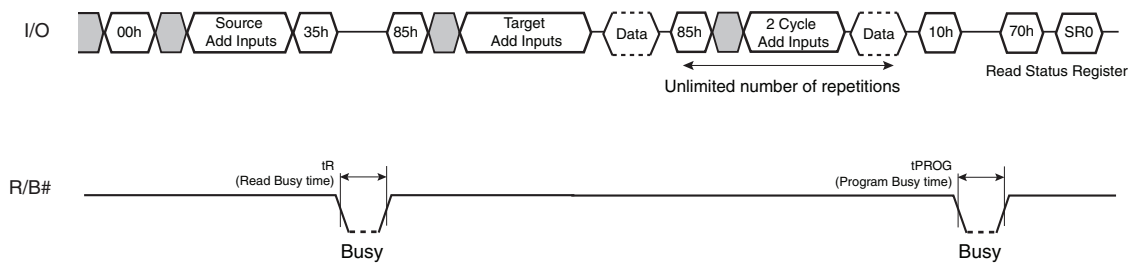

6.16 Read Status Register Timing

Figure 6.16 Status Read Cycle

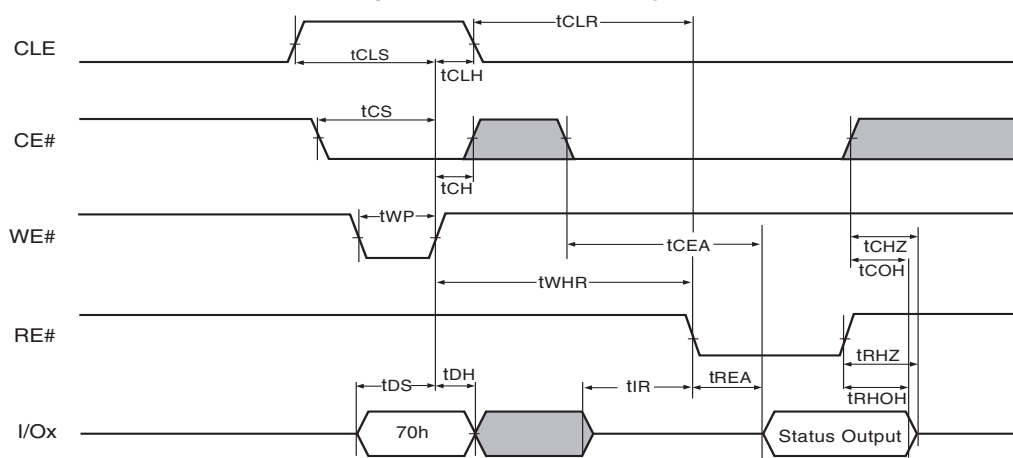

■ = Don't Care

6.17 Read Status Enhanced Timing

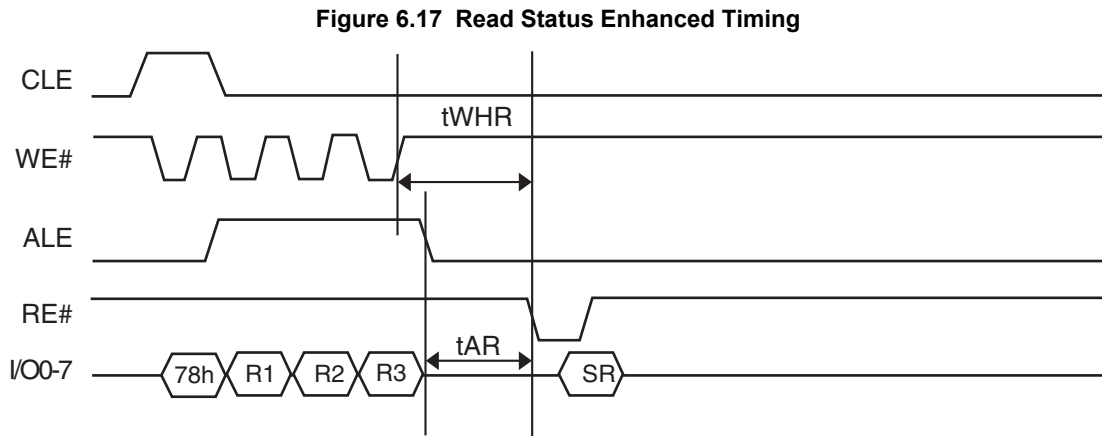

6.18 Reset Operation Timing

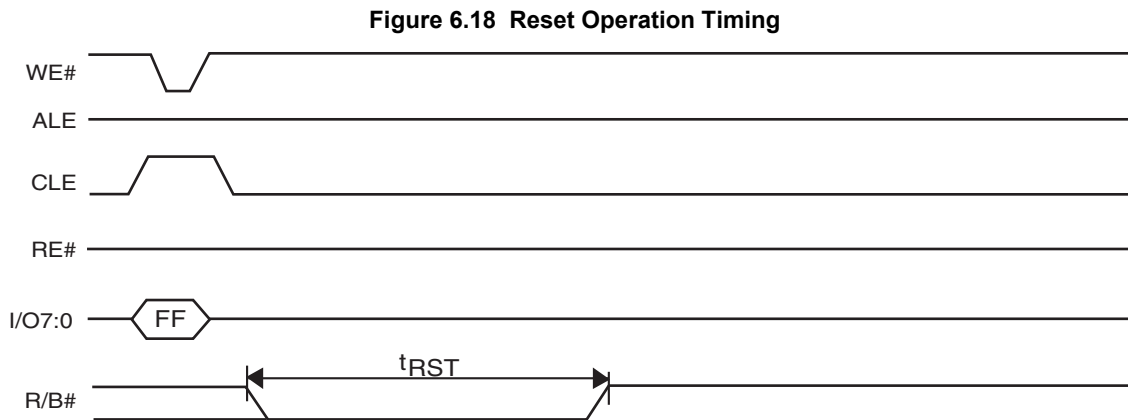

6.19 Read Cache

Figure 6.19 Read Cache Operation Timing

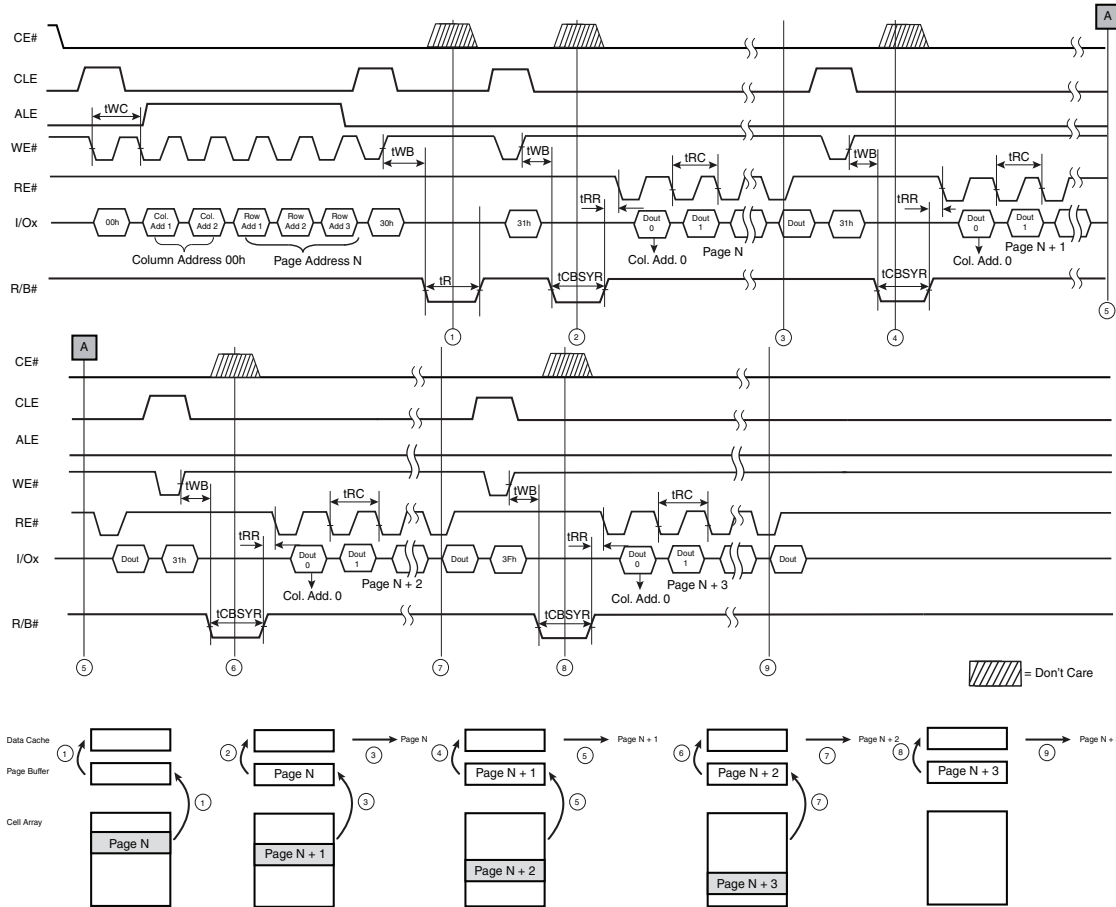

Figure 6.20 "Sequential" Read Cache Timing, Start (and Continuation) of Cache Operation

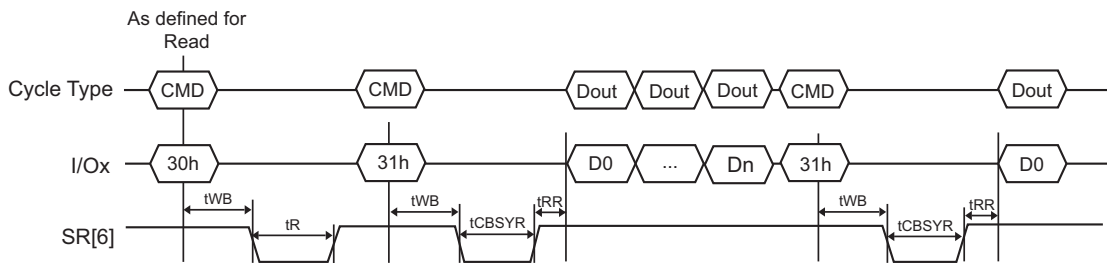

Figure 6.21 “Random” Read Cache Timing, Start (and Continuation) of Cache Operation

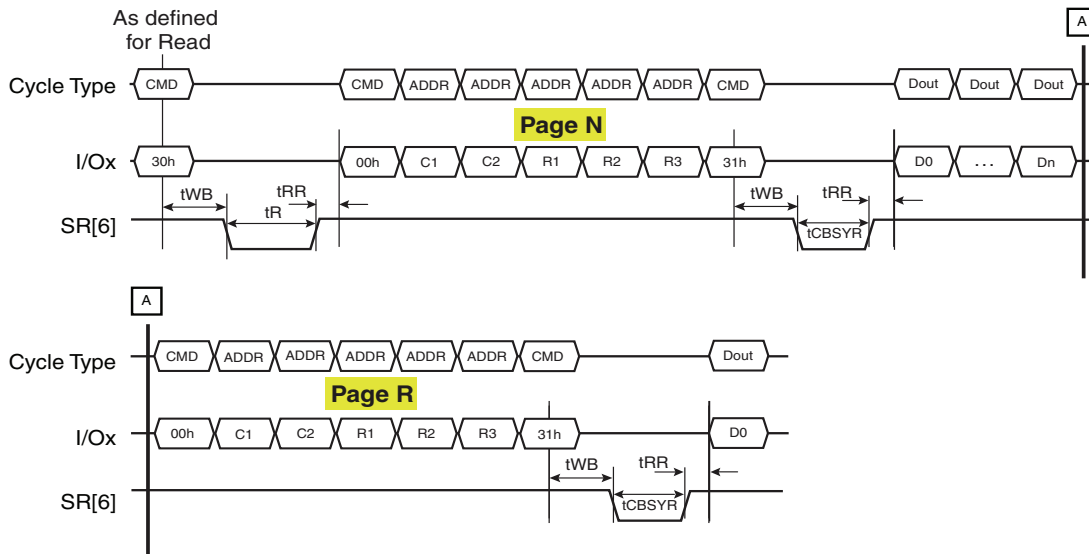
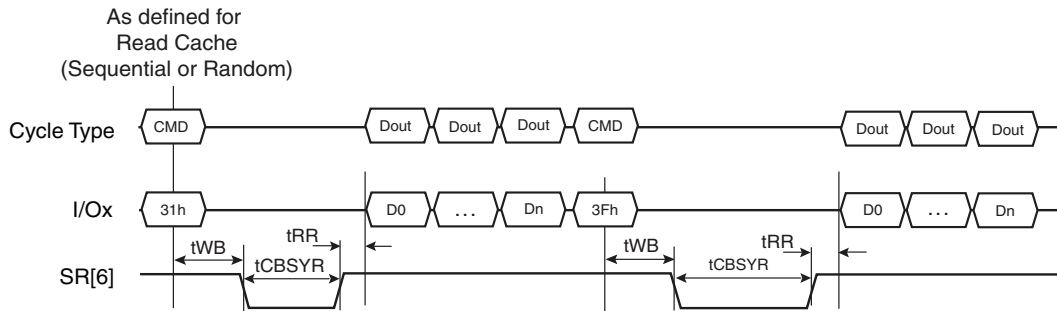
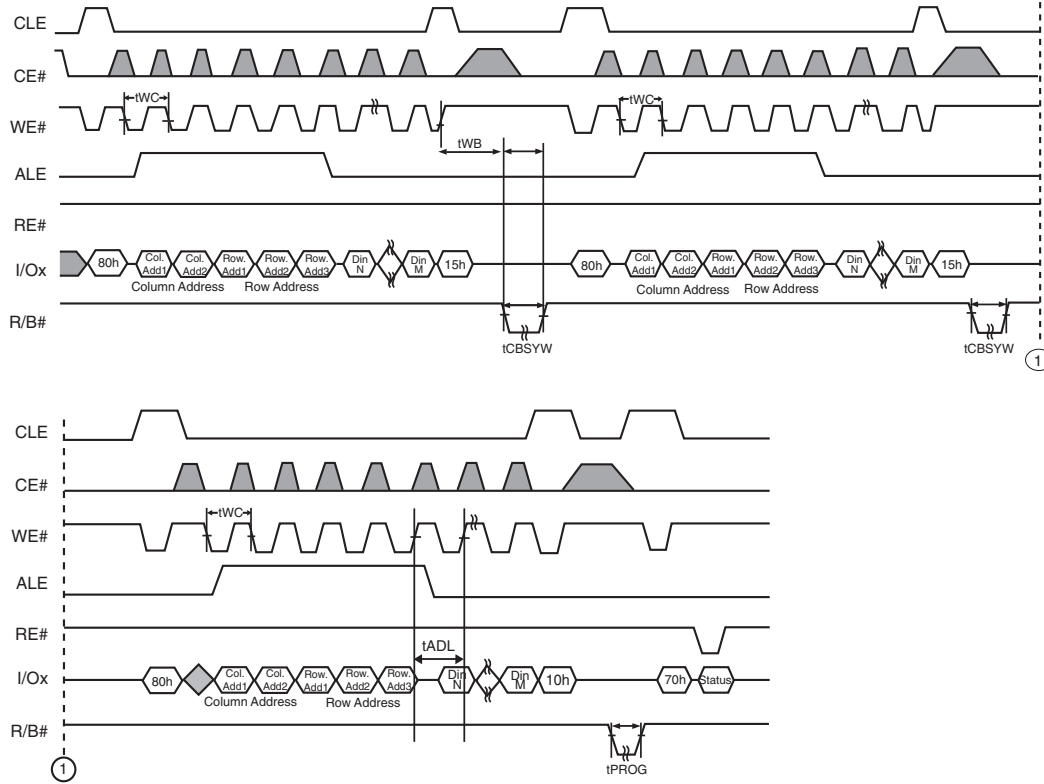

Figure 6.22 Read Cache Timing, End Of Cache Operation



6.20 Cache Program

Figure 6.23 Cache Program



6.21 Read ID Operation Timing (S34MS16G2)

Figure 6.24 Read ID Operation Timing

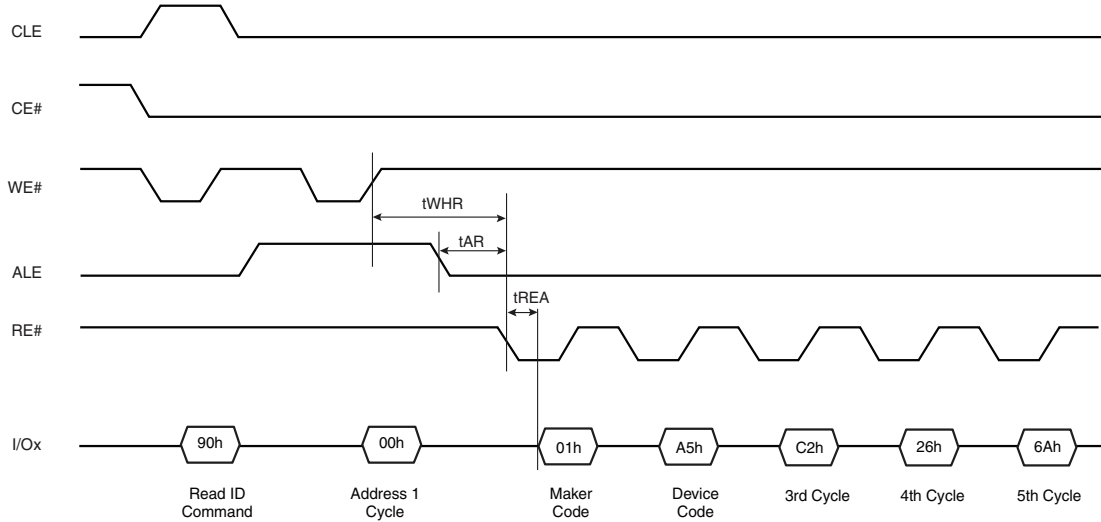

6.22 Read ID2 Operation Timing

Figure 6.25 Read ID2 Operation Timing

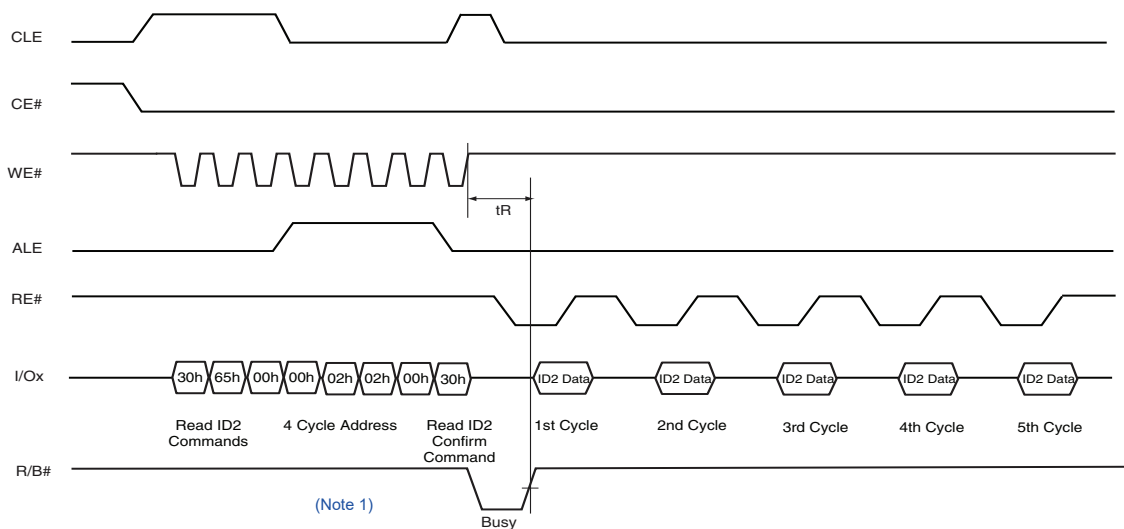

Notes:

1. For S34MS04G2, insert an additional address cycle of 00h.
2. If Status Register polling is used to determine completion of the Read ID2 operation, the Read Command (00h) must be issued before ID2 data can be read from the flash.

6.23 Read ONFI Signature Timing

Figure 6.26 ONFI Signature Timing

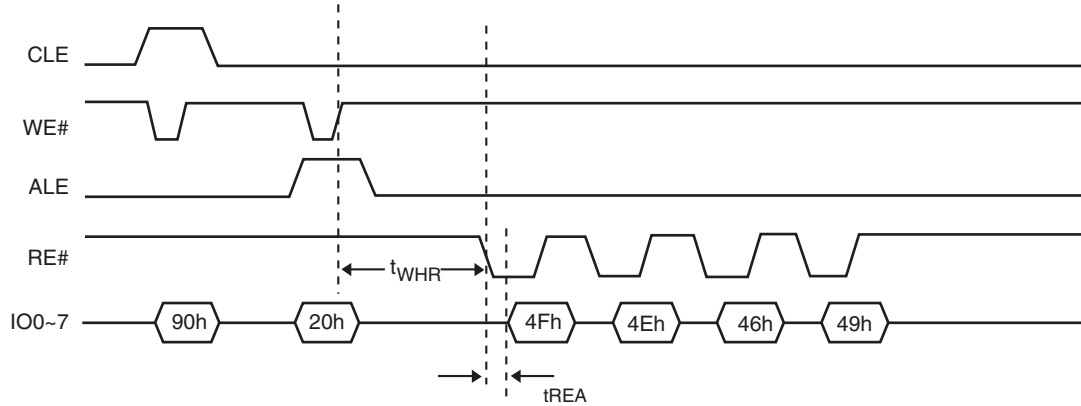

6.24 Read Parameter Page Timing

Figure 6.27 Read Parameter Page Timing

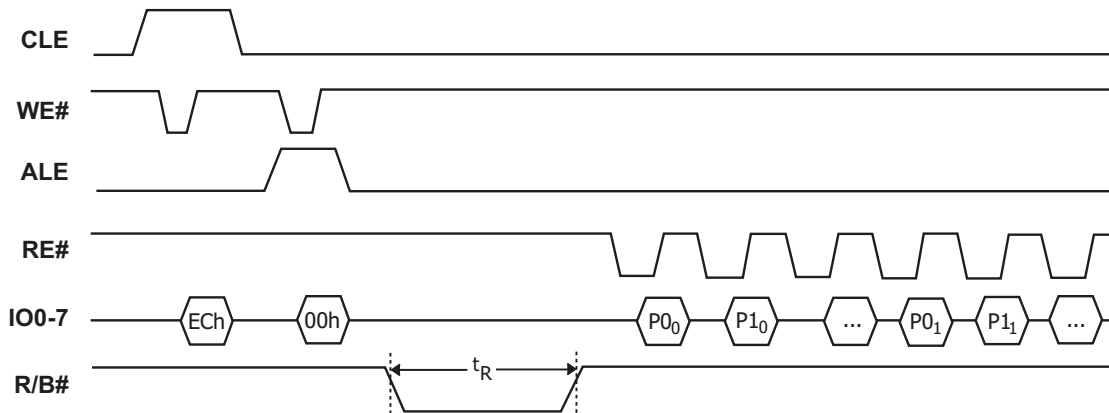

Note:

1. If Status Register polling is used to determine completion of the read operation, the Read Command (00h) must be issued before data can be read from the page buffer.

6.25 Read Unique ID Timing (Contact Factory)

Figure 6.28 Read Unique ID Timing

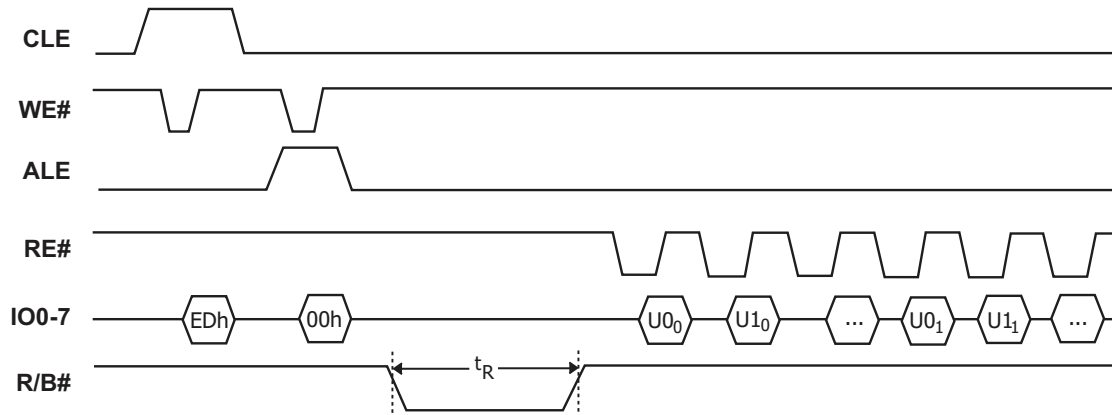

6.26 OTP Entry Timing

Figure 6.29 OTP Entry Timing

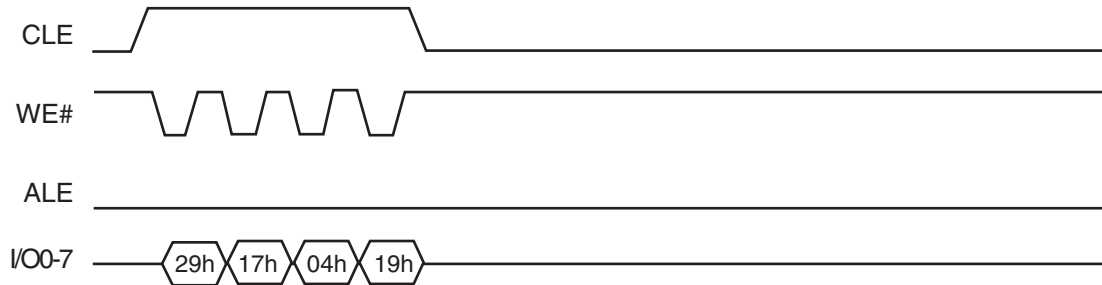

6.27 Power On and Data Protection Timing

Figure 6.30 Power On and Data Protection Timing

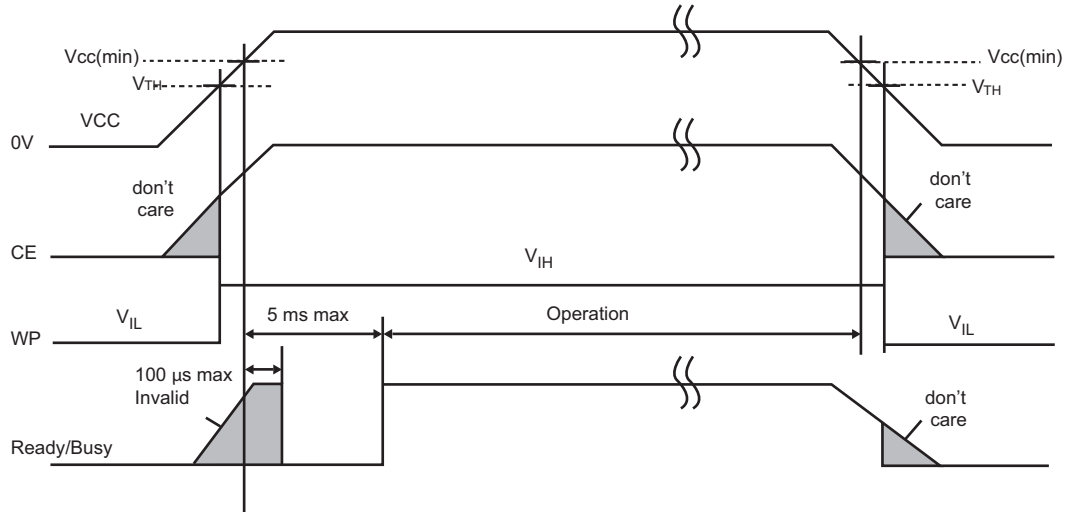

Note:

1. $V_{TH} = 1.2$ volts.

6.28 WP# Handling

Figure 6.31 Program Enabling / Disabling Through WP# Handling

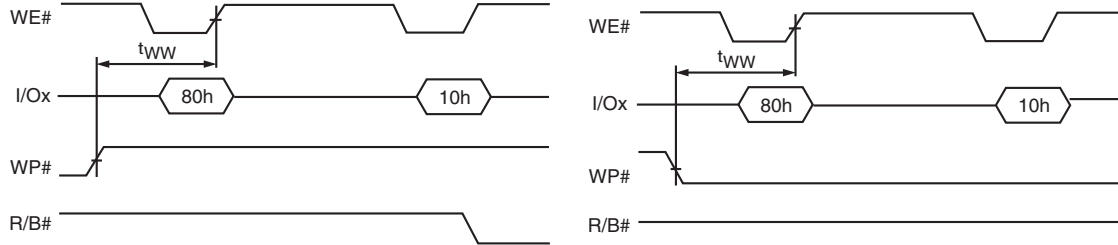
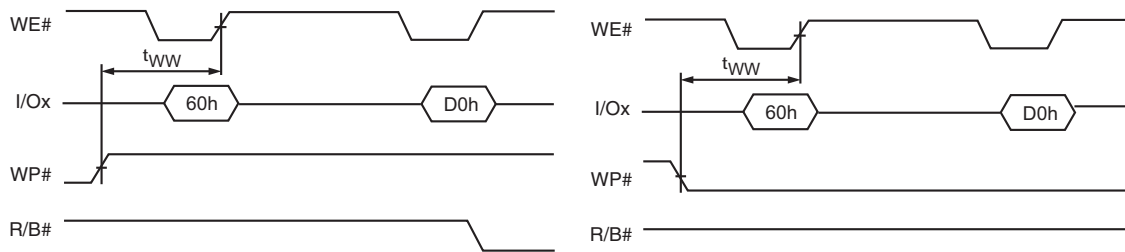

Figure 6.32 Erase Enabling / Disabling Through WP# Handling



7. System Interface

To simplify system interface, CE# may be unasserted during data loading or sequential data reading as shown in [Figure 8.1](#). By operating in this way, it is possible to connect NAND flash to a microprocessor.

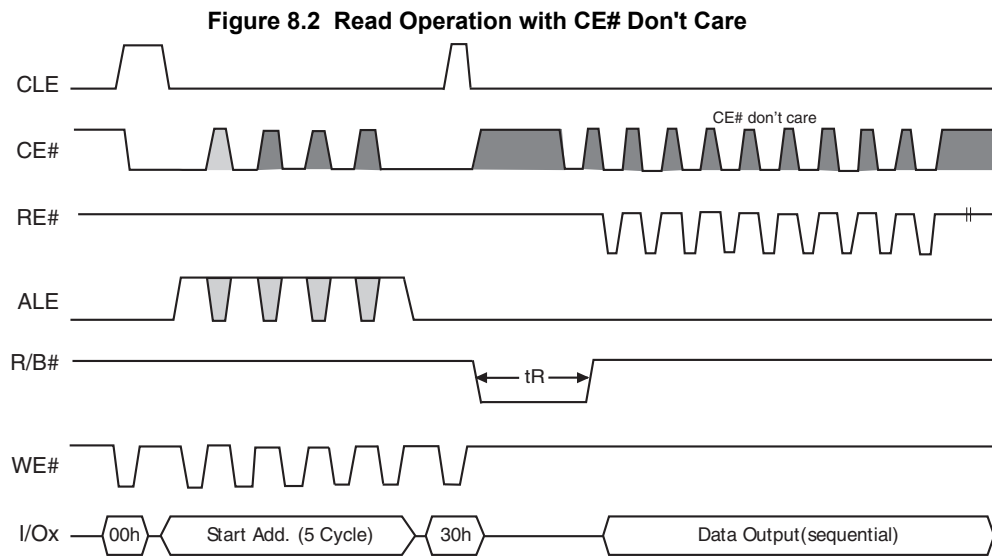
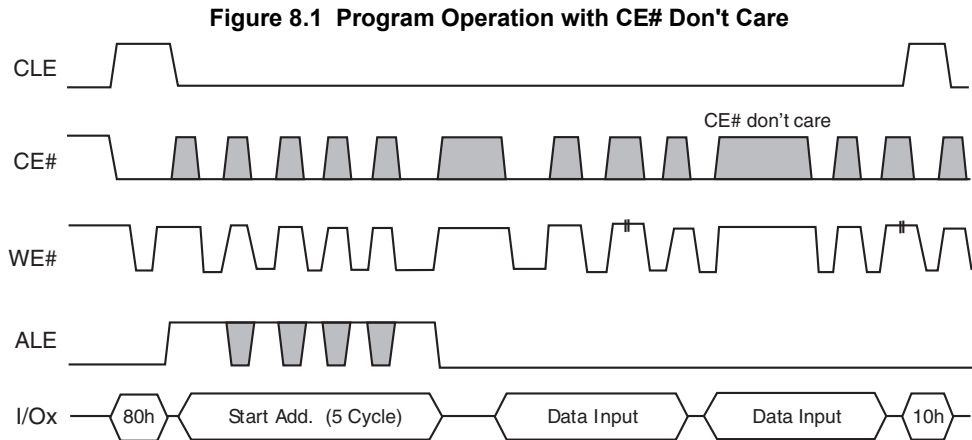
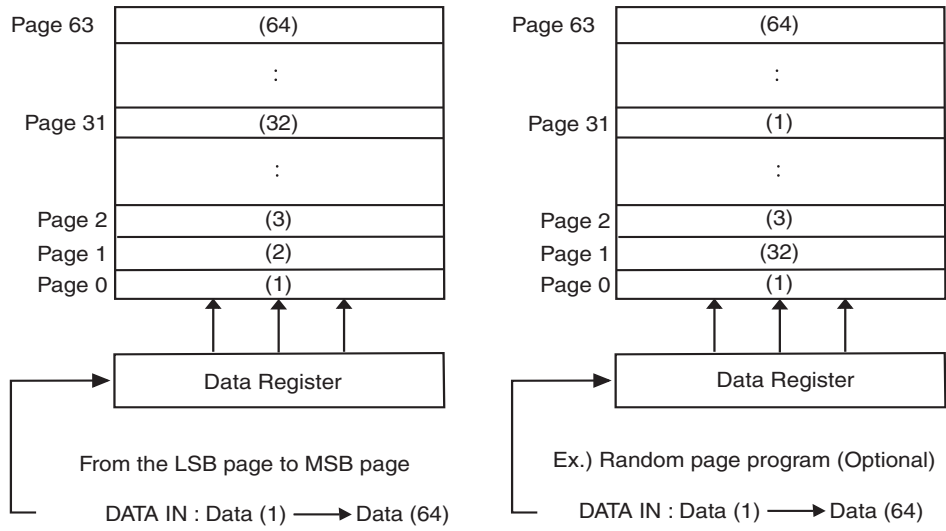

Figure 8.3 Page Programming Within a Block



8. Error Management

8.1 System Bad Block Replacement

Over the lifetime of the device, additional Bad Blocks may develop. In this case, each bad block has to be replaced by copying any valid data to a new block. These additional Bad Blocks can be identified whenever a program or erase operation reports “Fail” in the Status Register.

The failure of a page program operation does not affect the data in other pages in the same block, thus the block can be replaced by re-programming the current data and copying the rest of the replaced block to an available valid block. Refer to [Table 9.1](#) and [Figure 9.1](#) for the recommended procedure to follow if an error occurs during an operation.

Table 9.1 Block Failure

Operation	Recommended Procedure
Erase	Block Replacement
Program	Block Replacement
Read	ECC (4 bit / 512+32 byte)

Figure 9.1 Bad Block Replacement

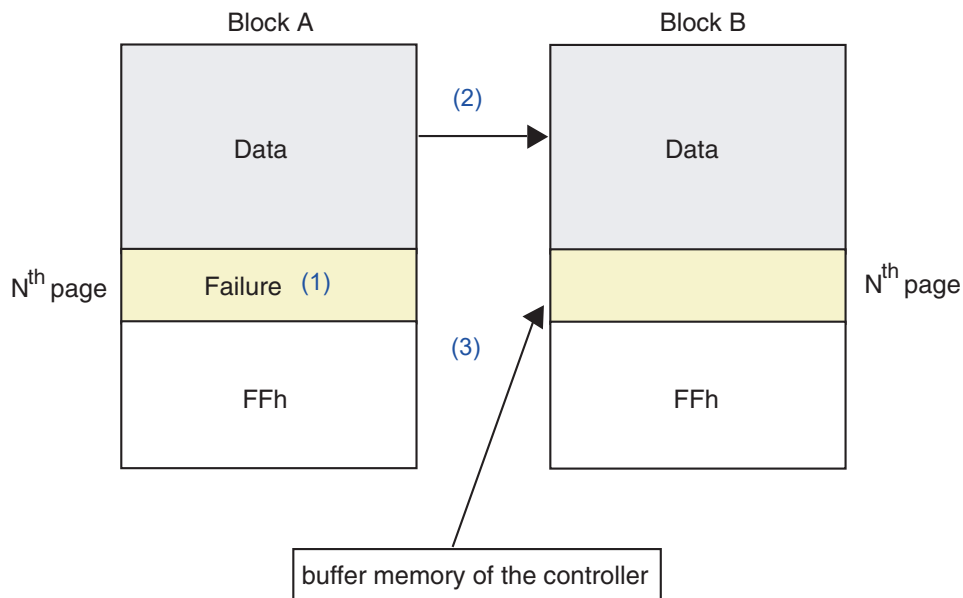

Notes:

1. An error occurs on the Nth page of Block A during a program operation.
2. Data in Block A is copied to the same location in Block B, which is a valid block.
3. The Nth page of block A, which is in controller buffer memory, is copied into the Nth page of Block B.
4. Bad block table should be updated to prevent from erasing or programming Block A.

8.2 Bad Block Management

Devices with Bad Blocks have the same quality level and the same AC and DC characteristics as devices where all the blocks are valid. A Bad Block does not affect the performance of valid blocks because it is isolated from the bit line and common source line by a select transistor. The devices are supplied with all the locations inside valid blocks erased (FFh). The Bad Block Information is written prior to shipping. Any block where the 1st byte in the spare area of the 1st or 2nd or last page does not contain FFh is a Bad Block. That is, if the first page has an FF value and should have been a non-FF value, then the non-FF value in the second page or the last page will indicate a bad block. The Bad Block Information must be read before any erase is attempted, as the Bad Block Information may be erased. For the system to be able to recognize the Bad Blocks based on the original information, it is recommended to create a Bad Block table following the flowchart shown in Figure 9.2. The host is responsible to detect and track bad blocks, both factory bad blocks and blocks that may go bad during operation. Once a block is found to be bad, data should not be written to that block. The 1st block, which is placed on 00h block address is guaranteed to be a valid block.

Figure 9.2 Bad Block Management Flowchart

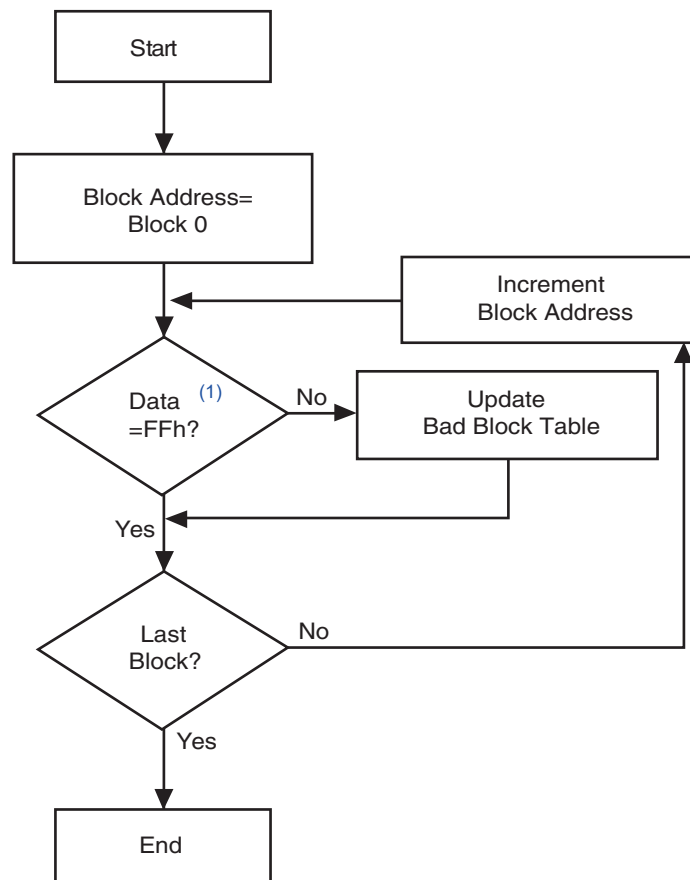

Note:

1. Check for FFh at the 1st byte in the spare area of the 1st, 2nd, and last pages.

8Gbit LPDDR4X SDRAM

FEATURES

- VDD1 = 1.8V (1.7V to 1.95V)
- VDD2 = 1.1V (1.06V to 1.17V)
- VDDQ = 0.6V (0.57V to 0.65V)
- Programmable CA ODT and DQ ODT with VSSQ termination
- VOH compensated output driver
- Single data rate command and address entry
- Double data rate architecture for data Bus;
 - two data accesses per clock cycle
- Differential clock inputs (CK_t, CK_c)
- Bi-directional differential data strobe (DQS_t, DQS_c)
- DMI pin support for write data masking and DBIdc functionality
- Programmable RL (Read Latency) and WL (Write Latency)
- Burst length: 16 (default), 32 and On-the-fly
 - On the fly mode is enabled by MRS
- Auto refresh and self refresh supported
- All bank auto refresh and directed per bank auto refresh supported
- Auto TCSR (Temperature Compensated Self Refresh)
- PASR (Partial Array Self Refresh) by Bank Mask and Segment Mask
- Background ZQ Calibration

Pin Description

Symbol	Type	Description
CK_t, CK_c	Input	Clock: CK_t and CK_c are differential clock inputs. All address, command, and control input signals are sampled on the crossing of the positive edge of CK_t and the negative edge of CK_c. AC timings for CA parameters are referenced to CK.
CKE	Input	Clock Enable: CKE HIGH activates and CKE LOW deactivates the internal clock circuits, input buffers, and output drivers. Power-saving modes are entered and exited via CKE transitions. CKE is part of the command code.
CS	Input	Chip Select: CS is part of the command code.
CA[5:0]	Input	Command/Address Inputs: CA signals provide the Command and Address inputs according to the Command Truth Table.
ODT(ca)	Input	CA ODT Control: The ODT_CA pin is used in conjunction with the Mode Register to turn on/off the On-Die-Termination for CA pins.
DQ[15:0]	I/O	Data Input/Output: Bi-direction data bus.
DQS[1:0]_t, DQS[1:0]_c	I/O	Data Strobe: DQS_t and DQS_c are bi-directional differential output clock signals used to strobe data during a READ or WRITE. The Data Strobe is generated by the DRAM for a READ and is edge-aligned with Data. The Data Strobe is generated by the Memory Controller for a WRITE and must arrive prior to Data. Each byte of data has a Data Strobe signal pair.
DMI[1:0]	I/O	Data Mask Inversion: DMI is a bi-directional signal which is driven HIGH when the data on the data bus is inverted, or driven LOW when the data is in its normal state. Data Inversion can be disabled via a mode register setting. Each byte of data has a DMI signal. This signal is also used along with the DQ signals to provide write data masking information to the DRAM. The DMI pin function - Data Inversion or Data mask - depends on Mode Register setting.
ZQ	Reference	Calibration Reference: Used to calibrate the output drive strength and the termination resistance. There is one ZQ pin per die. The ZQ pin shall be connected to VDDQ through a 240Ω ± 1% resistor.
VDDQ, VDD1, VDD2	Supply	Power Supplies: Isolated on the die for improved noise immunity.
VSS, VSSQ	GND	Ground Reference: Power supply ground reference
RESET_n	Input	RESET: When asserted LOW, the RESET_n signal resets the channel of the die. There is one RESET_n pad per die.

1. Functional Description

LPDDR4-SDRAM is a high-speed synchronous DRAM device internally configured with either 1 channel. Single-channel is comprised of 8-banks with from 1 Gb to 16 Gb per channel density. The device contains the following number of bits:

Single-channel SDRAM devices contain the following number of bits:

1Gb has 1,073,741,824 bits

2Gb has 2,147,483,648 bits

3Gb has 3,221,225,472 bits

4Gb has 4,294,967,296 bits

6Gb has 6,442,450,944 bits

8Gb has 8,589,934,592 bits

12Gb has 12,884,901,888 bits

16Gb has 17,179,869,184 bits

LPDDR4 devices use multi cycle of single data rate architecture on the Command/Address (CA) bus to reduce the number of input pins in the system. The 6-bit CA bus contains command, address and bank information. Each command uses two clock cycles, during which command information is transferred on positive edge of the corresponding clock.

These devices also use a double data rate architecture on the DQ pins to achieve high speed operation. The double data rate architecture is essentially an 16n prefetch architecture with an interface designed to transfer two data bits per DQ every clock cycle at the I/O pins. A single read or write access for the LPDDR4 SDRAM effectively consists of a single 16n-bit wide, one clock cycle data transfer at the internal DRAM core and eight corresponding n-bit wide, one-half-clock-cycle data transfers at the I/O pins.

Read and write accesses to the LPDDR4 SDRAMs are burst oriented; accesses start at a selected location and continue for a programmed number of locations in a programmed sequence. Accesses begin with the registration of an Activate command, which is then followed by a Read or Write command. The address and BA bits registered coincident with the Activate command are used to select the row and the bank to be accessed. The address bits registered coincident with the Read, Write or Mask Write command are used to select the bank and the starting column location for the burst access.

Prior to normal operation, the LPDDR4 SDRAM must be initialized. The following section provides detailed information covering device initialization, register definition, command description and device operation

1.1. LPDDR4 SDRAM Addressing

Memory Density (per Die)	1Gb	2Gb	3Gb	4Gb	6Gb	8Gb	12Gb	16Gb	
Memory Density (per x16 ch)	1Gb	2Gb	3Gb	4Gb	6Gb	8Gb	12Gb	16Gb	
Configuration	8Mb x 16DQ x 8 banks x 1 channels	16Mb x 16DQ x 8 banks x 1 channels	24Mb x 16DQ x 8 banks x 1 channels	32Mb x 16DQ x 8 banks x 1 channels	48Mb x 16DQ x 8 banks x 1 channels	64Mb x 16DQ x 8 banks x 1 channels	96Mb x 16DQ x 8 banks x 1 channels	128Mb x 16DQ x 8 banks x 1 channels	
Number of Channels (per die)	1	1	1	1	1	1	1	1	
Number of Banks (per Channel)	8	8	8	8	8	8	8	8	
Array Pre-Fetch (bits, perchannel)	256	256	256	256	256	256	256	256	
Number of Rows (per Channel)	8,192	16,384	24,576	32,768	49,152	65,536	98,304	131,072	
Number of Columns (fetch boundaries)	64	64	64	64	64	64	64	64	
Page Size (Bytes)	2048	2048	2048	2048	2048	2048	2048	2048	
Channel Density (Bits per channel)	1,073,741,824	2,147,483,648	3,221,225,472	4,294,967,296	6,442,450,944	8,589,934,592	12,884,901,888	17,179,869,184	
Total Density (Bits per die)	1,073,741,824	2,147,483,648	3,221,225,472	4,294,967,296	6,442,450,944	8,589,934,592	12,884,901,888	17,179,869,184	
Bank Address	BA0 - BA2	BA0 - BA2	BA0 - BA2	BA0 - BA2	BA0 - BA2	BA0 - BA2	BA0 - BA2	BA0 - BA2	
x16	Row Addresses	R0 - R12	R0 - R13	R0 - R14 (R13=0 when R14=1)	R0 - R14	R0 - R15 (R14=0 when R15=1)	R0 - R15	R0 - R16 (R15=0 when R16=1)	R0 - R16
	Column Addresses	C0 - C9	C0 - C9	C0 - C9	C0 - C9	C0 - C9	C0 - C9	C0 - C9	C0 - C9
Burst Starting Address Boundary	64 - bit	64 - bit	64 - bit	64 - bit	64 - bit	64 - bit	64 - bit	64 - bit	

1. The lower two column addresses (C0 - C1) are assumed to be "zero" and are not transmitted on the CA bus.
2. Row and Column address values on the CA bus that are not used for a particular density is required to be at valid logic levels.
3. For non - binary memory densities, only quarter of the row address space is invalid. When the MSB address bit is "HIGH", then the MSB - 1 address bit must be "LOW".
4. The row address input which violates restriction described in note 3 in this table may result in undefined or vendor specific behavior. Consult memory vendor for more information.

Memory Density (per Die)	1Gb	2Gb	3Gb	4Gb	6Gb	8Gb	12Gb	16Gb
Memory Density (per x8 ch)	1Gb	2Gb	3Gb	4Gb	6Gb	8Gb	12Gb	16Gb
Configuration	16Mb x 8DQ x 8 banks	32Mb x 8DQ x 8 banks	48Mb x 8DQ x 8 banks	64Mb x 8DQ x 8 banks	96Mb x 8DQ x 8 banks	128Mb x 8DQ x 8 banks	192Mb x 8DQ x 8 banks	256Mb x 8DQ x 8 banks
Number of Channels (per die)	1	1	1	1	1	1	1	1
Number of Banks (per Channel)	8	8	8	8	8	8	8	8
Array Pre-Fetch (bits, perchannel)	128	128	128	128	128	128	128	128
Number of Rows (per Channel)	16,384	32,768	49,152	65,536	98,304	131,072	196,608	262,144
Number of Columns (fetch boundaries)	64	64	64	64	64	64	64	64
Page Size (Bytes)	1024	1024	1024	1024	1024	1024	1024	1024
Channel Density (Bits per channel)	1,073,741,824	2,147,483,648	3,221,225,472	4,294,967,296	6,442,450,944	8,589,934,592	12,884,901,888	17,179,869,184
Total Density (Bits per die)	1,073,741,824	2,147,483,648	3,221,225,472	4,294,967,296	6,442,450,944	8,589,934,592	12,884,901,888	17,179,869,184
Bank Address	BA0 - BA2	BA0 - BA2	BA0 - BA2	BA0 - BA2	BA0 - BA2	BA0 - BA2	BA0 - BA2	BA0 - BA2
x8	Row Addresses	R0 - R13	R0 - R14 (R14=0 when R15=1)	R0 - R15	R0 - R16 (R15=0 when R16=1)	R0 - R16	R0 - R17 (R16=0 when R17=1)	R0 - R17
	Column Addresses	C0 - C9	C0 - C9	C0 - C9	C0 - C9	C0 - C9	C0 - C9	C0 - C9
Burst Starting Address Boundary	64 - bit	64 - bit	64 - bit	64 - bit	64 - bit	64 - bit	64 - bit	64 - bit

Notes

1. The lower two column addresses (C0 - C1) are assumed to be "zero" and are not transmitted on the CA bus.
2. Row and Column address values on the CA bus that are not used for a particular density is required to be at valid logic levels.
3. For non - binary memory densities, only quarter of the row address space is invalid. When the MSB address bit is "HIGH", then the MSB - 1 address bit must be "LOW".
4. The row address input which violates restriction described in note 3 in this table may result in undefined or vendor specific behavior. Consult memory vendor for more information.
5. Two byte-mode (one lower byte and one upper byte) die of a given density can be logically and physically combined into a 16-bit standard configuration with twice the given density. See Section of 2.1.1 for an example.

1.2. Simplified State Diagram

The state diagram provides a simplified illustration of the bus interface, supported state transitions, and the commands that control them. For a complete description of device behavior, use the information provided in the state diagram with the truth tables and timing specifications. The truth tables describe device behavior and applicable restrictions when considering the actual state of all banks. For command descriptions, see the Commands and Timing section.

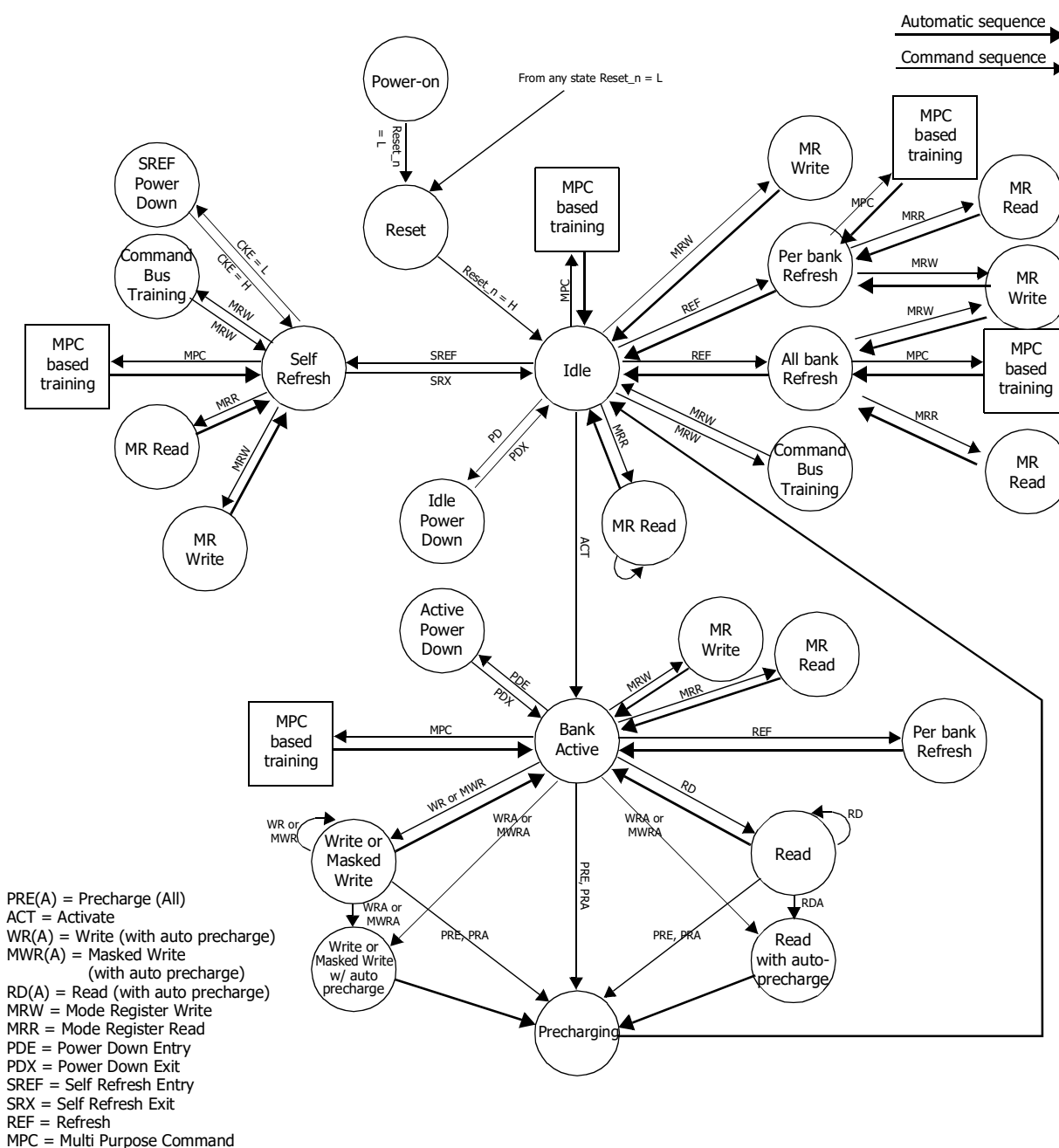

Figure 1 - Simplified State Diagram

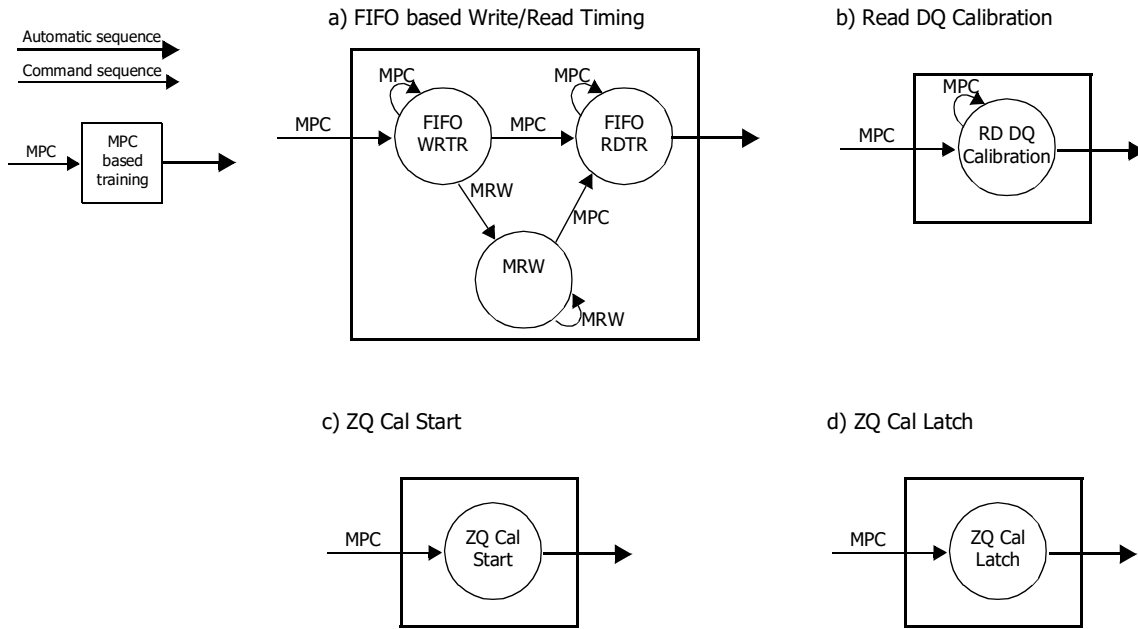

Figure 2 - Simplified Bus Interface State Diagram

Notes

1. From the Self-Refresh state the device can enter Power-Down, MRR, MRW, or MPC states. See the section on Self-Refresh for more information.
2. In IDLE state, all banks are pre-charged.
3. In the case of a MRW command to enter a training mode, the state machine will not automatically return to the IDLE state at the conclusion of training. See the applicable training section for more information.
4. In the case of a MPC command to enter a training mode, the state machine may not automatically return to the IDLE state at the conclusion of training. See the applicable training section for more information.
5. This simplified State Diagram is intended to provide an overview of the possible state transitions and the commands to control them. In particular, situations involving more than one bank, the enabling or disabling of on-die termination, and some other events are not captured in full detail.
6. States that have an "automatic return" and can be accessed from more than one prior state (Ex. MRW from either Idle or Active states) will return to the state from when they were initiated (Ex. MRW from Idle will return to Idle).
7. The RESET_n pin can be asserted from any state, and will cause the SDRAM to go to the Reset State. The diagram shows RESET applied from the Power-On as an example, but the Diagram should not be construed as a restriction on RESET_n.

1.3. Power-up and Initialization

For power-up and reset initialization, in order to prevent DRAM from functioning improperly, default values of the following MR settings are defined as following table.

Table 1 - MRS defaults settings

Item	MRS	Default setting	Description
FSP-OP/WR	MR13 OP[7:6]	00B	FS-OP/WR[0] are enabled
WLS	MR2 OP[6]	0B	Write Latency Set 0 is selected
WL	MR2 OP[5:3]	000B	WL = 4
RL	MR2 OP[2:0]	000B	RL = 6, nRTP = 8
nWR	MR1 OP[6:4]	000B	nWR = 6
DBI-WR/RD	MR3 OP[7:6]	00B	Write & Read DBI are disabled
CA ODT	MR11 OP[6:4]	000B	CA ODT is disabled
DQ ODT	MR11 OP[2:0]	000B	DQ ODT is disabled
VREF(CA) Setting	MR12 OP[6]	1B	VREF(CA) Range[1] enabled
VREF(CA) value	MR12 OP[5:0]	011101B	Range1: 50.3% of VDDQ
VREF(DQ) Setting	MR14 OP[6]	1B	VREF(DQ) Range[1] enabled
VREF(DQ) Value	MR14 OP[5:0]	011101B	Range1: 50.3% of VDDQ

1.3.1. Voltage Ramp and Device Initialization

The following sequence shall be used to power up the LPDDR4 device. Unless specified otherwise, these steps are mandatory. Note that the power-up sequence of all channels must proceed simultaneously.

1. While applying power (after T_a), RESET_n is recommended to be LOW ($\leq 0.2 \times VDD2$) and all other inputs must be between VIL_{min} and VIH_{max} . The device outputs remain at High-Z while RESET_n is held LOW. Power supply voltage ramp requirements are provided in Table "Voltage Ramp Conditions". VDD1 must ramp at the same time or earlier than VDD2. VDD2 must ramp at the same time or earlier than VDDQ.

Table 2 - Voltage Ramp Conditions

After	Applicable Conditions
Ta is reached	VDD1 must be greater than VDD2
	VDD2 must be greater than VDDQ - 200mV

Notes

1. T_a is the point when any power supply first reaches 300mV.
2. Voltage ramp conditions in above table apply between T_a and power-off (controlled or uncontrolled).
3. T_b is the point at which all supply and reference voltages are within their defined ranges.
4. Power ramp duration t_{INIT0} ($T_b - T_a$) must not exceed 20ms.
5. The voltage difference between any of VSS and VSSQ pins must not exceed 100mV.

2. Following the completion of the voltage ramp (Tb), RESET_n must be maintained LOW. DQ, DMI, DQS_t and DQS_c voltage levels must be between Vssq and Vddq during voltage ramp to avoid latch-up. CKE, CK_t, CK_c, CS_n and CA input levels must be between Vss and VDD2 during voltage ramp to avoid latch-up.

3. Beginning at Tb, RESET_n must remain LOW for at least tINIT1(Tc), after which RESET_n can be de-asserted to HIGH(Tc). At least 10ns before Reset_n de-assertion, CKE is required to be set LOW. All other input signals are "Don't Care".

Figure 3 - Power Ramp and Initialization Sequence

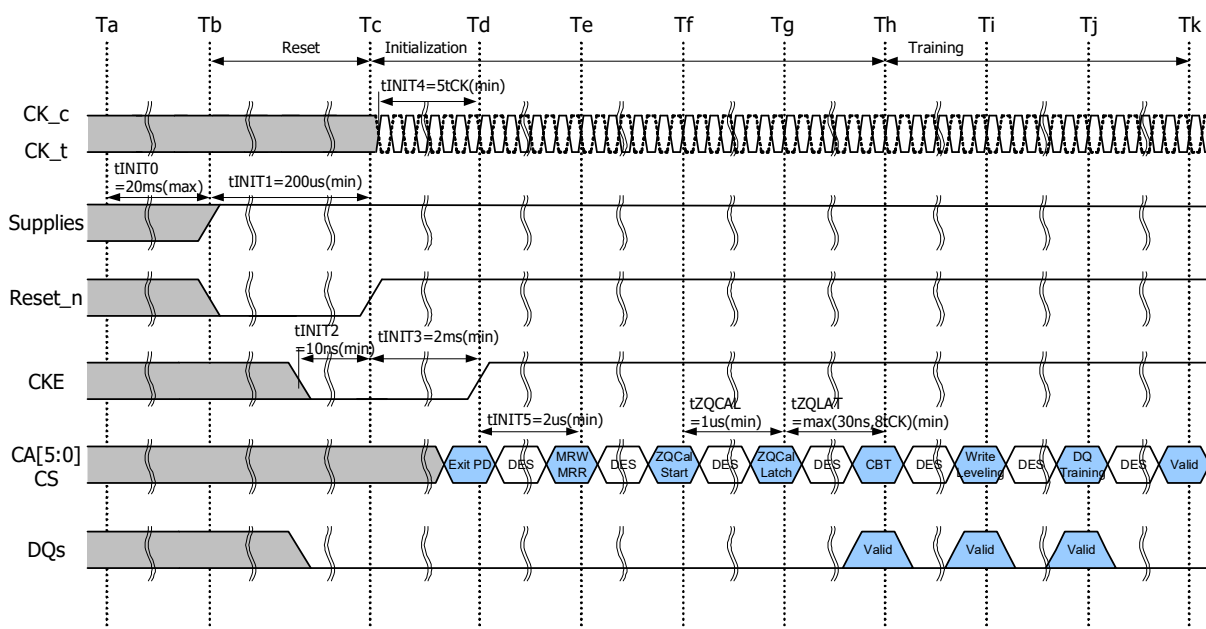

Notes

1. Training is optional and may be done at the system architects discretion. The training sequence after ZQ_CAL Latch(Th, Sequence7~9) in the above figure, is simplified recommendation and actual training sequence may vary depending on systems.

4. After RESET_n is de-asserted(Tc), wait at least tINIT3 before activating CKE. Clock(CK_t,CK_c) is required to be started and stabilized for tINIT4 before CKE goes active(Td). CS is required to be maintained LOW when controller activates CKE.

5. After setting CKE high, wait minimum of tINIT5 to issue any MRR or MRW commands(Te). For both MRR and MRW commands, the clock frequency must be within the range defined for tCKb. Some AC parameters (for example, tDQSCK) could have relaxed timings (such as tDQSCKb) before the system is appropriately configured.

6. After completing all MRW commands to set the Pull-up, Pull-down and Rx termination values, the DRAM controller can issue ZQCAL Start command to the memory(Tf). This command is used to calibrate VOH level and output impedance over process, voltage and temperature. In systems where more than one LPDDR4 DRAM devices share one external ZQ resistor, the controller must not overlap the ZQ calibration sequence of each LPDDR4 device. ZQ calibration sequence is completed after tZQCAL (Tg) and the ZQCAL Latch command must be issued to update the DQ drivers and DQ+CA ODT to the calibrated values.

7. After tZQLAT is satisfied (Th) the command bus (internal VREF(CA), CS, and CA) should be trained for high-speed operation by issuing an MRW command (Command Bus Training Mode). This command is used to calibrate the device's internal VREF and align CS/CA with CK for high-speed operation. The LPDDR4 device will power-up with receivers configured for low-speed operations, and

VREF(CA) set to a default factory setting. Normal device operation at clock speeds higher than tCKb may not be possible until command bus training has been completed.

The command bus training MRW command uses the CA bus as inputs for the calibration data stream, and outputs the results asynchronously on the DQ bus. See command bus training in the MRW section for information on how to enter/exit the training mode.

8. After command bus training, DRAM controller must perform write leveling. Write leveling mode is enabled when MR2 OP[7] is high(Ti). See write leveling section for detailed description of write leveling entry and exit sequence. In write leveling mode, the DRAM controller adjusts write DQS_t/_c timing to the point where the LPDDR4 device recognizes the start of write DQ data burst with desired write latency.

9. After write leveling, the DQ Bus (internal VREF(DQ), DQS, and DQ) should be trained for high-speed operation using the MPC training commands and by issuing MRW commands to adjust VREF(DQ)(Tj). The LPDDR4 device will power-up with receivers configured for low-speed operations and VREF(DQ) set to a default factory setting. Normal device operation at clock speeds higher than tCKb should not be attempted until DQ Bus training has been completed. The MPC Read Calibration command is used together with MPC FIFO Write/Read commands to train DQ bus without disturbing the memory array contents. See DQ Bus Training section for detailed DQ Bus Training sequence.

10. At Tk the LPDDR4 device is ready for normal operation, and is ready to accept any valid command. Any more registers that have not previously been set up for normal operation should be written at this time.

Table 3 - Initialization Timing Parameters

Parameter	Value		Unit	Comment
	Min	Max		
tINIT0		20	ms	Maximum Voltage Ramp Time
tINIT1	200		us	Minimum RESET_n LOW time after completion of voltage ramp
tINIT2	10		ns	Minimum CKE LOW time before RESET_n goes HIGH
tINIT3	2		ms	Minimum CKE LOW time after RESET_n goes HIGH
tINIT4	5		tCK	Minimum stable clock before first CKE HIGH
tINIT5	2		us	Minimum idle time before first MRW/MRR command
tZQCAL	1		us	ZQ Calibration time
tZQLAT	Max(30ns.8tCK)		ns	ZQCAL latch quite time
tCKb	Note 1, 2	Note 1, 2	ns	Clock cycle time during boot

Notes

1. Min tCKb guaranteed by DRAM test is 18ns.
2. The system may boot at a higher frequency than dictated by min tCKb. The higher boot frequency is system dependent

1.3.2. Reset Initialization with Stable Power

The following sequence is required for RESET at no power interruption initialization.

1. Assert RESET_n below 0.2 x VDD2 anytime when reset is needed. RESET_n needs to be maintained for minimum tPW_RESET. CKE must be pulled LOW at least 10 ns before de-asserting RESET_n.
2. Repeat steps 4 to 10 in "Voltage Ramp and Device Initialization" section.

Table 4 - Reset Timing Parameter

Parameter	Value		Unit	Comment
	Min	Max		
tPW_RESET	100	-	ns	Minimum RESET_n low time for Reset Initialization with stable power

1.3.3. Power-off Sequence

The following procedure is required to power off the device.

While powering off, CKE must be held LOW ($\leq 0.2 \times VDD2$) and all other inputs must be between VILmin and VIHmax. The device outputs remain at High-Z while CKE is held LOW. DQ, DMI, DQS_t and DQS_c voltage levels must be between VSSQ and VDDQ during voltage ramp to avoid latch-up. RESET_n, CK_t, CK_c, CS and CA input levels must be between VSS and VDD2 during voltage ramp to avoid latch-up.

Tx is the point where any power supply drops below the minimum value specified.

Tz is the point where all power supplies are below 300mV. After TZ, the device is powered off.

Table 5 - Power Supply Conditions for Power-off

Between	Applicable Conditions
TX and TZ	VDD1 must be greater than VDD2
	VDD2 must be greater than VDDQ - 200mV

Notes

The voltage difference between any of VSS, VSSQ pins must not exceed 100mV

1.3.4. Uncontrolled Power-off Sequence

When an uncontrolled power-off occurs, the following conditions must be met:

At Tx, when the power supply drops below the minimum values specified, all power supplies must be turned off and all power supply current capacity must be at zero, except any static charge remaining in the system.

After Tz (the point at which all power supplies first reach 300mV), the device must power off. During this period the relative voltage between power supplies is uncontrolled. VDD1 and VDD2 must decrease with a slope lower than 0.5V/ μ s between Tx and Tz.

An uncontrolled power-off sequence can occur a maximum of 400 times over the life of the device.

Table 6 - Timing Parameters for Power-off

Symbol	Value		Unit	Comment
	Min	Max		
tPOFF	-	2	s	Maximum Power-off ramp time

1.4. Mode Register Definition

Table below shows the mode registers for LPDDR4 SDRAM. Each register is denoted as "R" if it can be read but not written, "W" if it can be written but not read, and "R/W" if it can be read and written. A Mode Register Read command is used to read a mode register. A Mode Register Write command is used to write a mode register.

Table 7 - Mode Register Assignment

MR#	OP7	OP6	OP5	OP4	OP3	OP2	OP1	OP0
0	Reserved	RFU		RZQI		RFU	Latency Mode	Refresh Mode
1	RPST	nWR (for AP)			RD-PRE	WR-PRE		
2	WR Lev	WLS	WL			RL		
3	DBI-WR	DBI-RD	PDDS			PPRP	WR-PST	PU-CAL
4	TUF	Thermal Offset		PPRE	SR Abort	Refresh Rate		
5	LPDDR4 Manufacturer ID							
6	Revision ID-1							
7	Revision ID-2							
8	IO Width		Density				Type	
9	Vendor Specific Test Mode							
10	RFU							ZQ Reset
11	RFU	CA ODT			RFU	DQ ODT		
12	CBT Mode	VR-CA	VREF(CA)					
13	FSP-OP	FSP-WR	DMD	RRO	VRCG	VRO	RPT	CBT
14	RFU	VR(DQ)	VREF(DQ)					
15	Lower Byte Invert for DQ Calibration							
16	PASR Bank Mask							
17	PASR Segment Mask							
18	DQS Oscillator Count - LSB							
19	DQS Oscillator Count - MSB							
20	Upper Byte Invert for DQ Calibration							
21	RFU							
22	ODT for x8 2ch(Byte) mode	ODTD-CA	ODTE-CS	ODTE-CK	CODT			
23	DQS Oscillator Interval Timer Run Time Setting							
24	TRR Mode	TRR Mode BAn			Unlimited MAC	MAC Value		
25	Post Package Repair Resources							
26	RFU							
27	RFU							
28	RFU							
29	RFU							
30	RFU							
31	RFU							
32	See "DQ Calibration" section							
33:39	RFU							
40	See "DQ Calibration" section							
41:47	Do Not Use							
48:63	RFU							

1. RFU bits should be set to '0' during mode register writes
2. RFU bits should be read as '0' during mode register reads
3. All mode registers that are specified as RFU or Write-only shall return undefined data when read and DQS_t/DQS_c shall be toggled
4. All mode registers that are specified as RFU shall not be written
5. See vendor device datasheet for details on vendor-specific mode registers
6. Writes to Read-only registers shall have no effect on the functionality of the device

1.4.1. MR0 Register Information (MA[5:0] = 00H)

OP[7]	OP[6]	OP[5]	OP[4]	OP[3]	OP[2]	OP[1]	OP[0]
Reserved	RFU		RZQI		RFU	Latency Mode	Refresh Mode

Function	Register Type	Operand	Data	Notes
Refresh Mode	Read-only	OP[0]	0B: Both legacy & modified refresh mode supported 1B: Only modified refresh mode supported	
Latency Mode		OP[1]	0B: Device supports normal latency 1B: Device supports byte mode latency	5,6
RZQI (Built-in Self-Test for RZQ)		OP[4:3]	00B: RZQ Self-Test Not Supported 01B: ZQ pin may connect to VSSQ or float 10B: ZQ-pin may short to VDDQ 11B: ZQ-pin Self-Test Completed, no error condition detected (ZQ-pin may not connect to VSSQ or float, nor short to VDDQ)	1,2,3,4

Notes

1. RZQI MR value, if supported, will be valid after the following sequence:
 - a. Completion of MPC ZQCAL Start command to the channel.
 - b. Completion of MPC ZQCAL Latch command to the channel then tZQLAT is satisfied. RZQI value will be lost after Reset.
2. If the ZQ-pin is connected to VSSQ to set default calibration, OP[4:3] shall be set to 01B.
If the ZQ-pin is not connected to VSSQ, either OP[4:3] = 01B or OP[4:3] = 10B might indicate might indicate a ZQ-pin assembly error.
It is recommended that the assembly error is corrected.
3. In the case of possible assembly error, the LPDDR4-SDRAM device will default to factory trim settings for RON, and will ignore ZQ Calibration commands. In either case, the device may not function as intended.
4. If ZQ Self-Test returns OP[4:3] = 11B, the device has detected a resistor connected to the ZQ-pin. However, this result cannot be used to validate the ZQ resistor value or that the ZQ resistor tolerance meets the specified limits (i.e., 240 Ω ± 1%).
5. See byte mode addendum spec for byte mode latency details.
6. Byte mode latency for 2Ch. x16 device is only allowed when it is stacked in a same package with byte mode device.

1.4.2. MR1 Register Information (MA[5:0] = 01H)

OP[7]	OP[6]	OP[5]	OP[4]	OP[3]	OP[2]	OP[1]	OP[0]
RPST	nWR (for AP)			RD-PRE	WR-PRE	BL	

Function	Register Type	Operand	Data	Notes
BL (Burst Length)	Write-only	OP[1:0]	00B: BL=16 Sequential (default) 01B: BL=32 Sequential 10B: BL=16 or 32 Sequential (on-the-fly) All Others: Reserved	1,7
WR-PRE (WR Pre-amble Length)		OP[2]	0B: Reserved 1B: WR Pre-amble = 2tCK (default)	5,6
RD-PRE (RD Pre-amble Type)		OP[3]	0B: RD Pre-amble = Static (default) 1B: RD Pre-amble = Toggle	3,5,6
nWR (Write-Recovery for Auto Precharge commands)		OP[6:4]	For x16 mode 000 _B : nWR = 6 (default) 001 _B : nWR = 10 010 _B : nWR = 16 011 _B : nWR = 20 100 _B : nWR = 24 101 _B : nWR = 30 110 _B : nWR = 34 111 _B : nWR = 40 For Byte (x8) mode 000 _B : nWR = 6 (default) 001 _B : nWR = 12 010 _B : nWR = 16 011 _B : nWR = 22 100 _B : nWR = 28 101 _B : nWR = 32 110 _B : nWR = 38 111 _B : nWR = 44	2,5,6
RPST (RD Post-amble Length)		OP[7]	0B: RD Post-amble = 0.5*tCK (default) 1B: RD Post-amble = 1.5*tCK	4,5,6

Notes

- Burst length on-the-fly can be set to either BL=16 or BL=32 by setting the "BL" bit in the command operands. See the Command Truth Table.
- The programmed value of nWR is the number of clock cycles the LPDDR4-SDRAM device uses to determine the starting point of an internal Precharge operation after a Write burst with AP (auto-precharge) enabled.
- For Read operations this bit must be set to select between a "toggling" pre-amble and a "Non-toggling" Pre-amble.
- OP[7] provides an optional READ post-amble with an additional rising and falling edge of DQS_t. The optional postamble cycle is provided for the benefit of certain memory controllers.
- There are two physical registers assigned to each bit of this MR parameter, designated set point 0 and set point 1. Only the registers for the set point determined by the state of the FSP-WR bit (MR13 OP[6]) will be read from with an MRR command to this MR address.
- There are two physical registers assigned to each bit of this MR parameter, designated set point 0 and set point 1. The device will operate only according to the values stored in the registers for the active set point, i.e., the set point determined by the state of the FSP-OP bit (MR13 OP[7]). The values in the registers for the inactive set point will be ignored by the device, and may be changed without affecting device operation.
- Supporting the two physical registers for Burst Length: MR1 OP[1:0] as optional feature. Applications requiring support of both vendor options shall assure that both FSP-OP[0] and FSP-OP[1] are set to the same code. Refer to vendor datasheets for detail

1.4.3. MR2 Register Information (MA[5:0] = 02H)

OP[7]	OP[6]	OP[5]	OP[4]	OP[3]	OP[2]	OP[1]	OP[0]
WR Lev	WLS	WL			RL		

Function	Register Type	Operand	Data	Notes
RL (Read latency)	Write-only	OP[2:0]	<p>For Byte (x8) mode RL & nRTP for DBI-RD Disabled (MR3 OP[6]=0_B) 000_B: RL= 6 & nRTP = 8 (Default) 001_B: RL= 10 & nRTP = 8 010_B: RL= 16 & nRTP = 8 011_B: RL= 22 & nRTP = 8 100_B: RL= 26 & nRTP = 10 101_B: RL= 32 & nRTP = 12 110_B: RL= 36 & nRTP = 14 111_B: RL= 40 & nRTP = 16</p> <p>RL & nRTP for DBI-RD Enabled (MR3 OP[6]=1_B) 000_B: RL= 6 & nRTP = 8 001_B: RL= 12 & nRTP = 8 010_B: RL= 18 & nRTP = 8 011_B: RL= 24 & nRTP = 8 100_B: RL= 30 & nRTP = 10 101_B: RL= 36 & nRTP = 12 110_B: RL= 40 & nRTP = 14 111_B: RL= 44 & nRTP = 16</p>	1,3,4
WL (Write latency)	Write-only	OP[5:3]	<p>For Byte (x8) mode WL Set "A" (MR2 OP[6]=0_B) 000_B: WL=4 (Default) 001_B: WL=6 010_B: WL=8 011_B: WL=10 100_B: WL=12 101_B: WL=14 110_B: WL=16 111_B: WL=18</p> <p>WL Set "B" (MR2 OP[6]=1_B) 000_B: WL=4 001_B: WL=8 010_B: WL=12 011_B: WL=18 100_B: WL=22 101_B: WL=26 110_B: WL=30 111_B: WL=34</p>	1,3,4
WLS (Write Latency Set)		OP[6]	0 _B : WL Set "A" (default) 1 _B : WL Set "B"	1,3,4
WR LEV (Write Leveling)		OP[7]	0 _B : Disabled (default) 1 _B : Enabled	2

1. See Latency Code Frequency Table for allowable frequency ranges for RL/WL/nWR/nRTP.
2. After a MRW to set the Write Leveling Enable bit (OP[7]=1B), the LPDDR4-SDRAM device remains in the MRW state until another MRW command clears the bit (OP[7]=0B). No other commands are allowed until the Write Leveling Enable bit is cleared.
3. There are two physical registers assigned to each bit of this MR operand, designated set point 0 and set point 1. Only the registers for the set point determined by the state of the FSP-WR bit (MR13 OP[6]) will be written to with an MRW command to this MR address.
4. There are two physical registers assigned to each bit of this MR operand, designated set point 0 and set point 1. The device will operate only according to the values stored in the registers for the active set point, i.e., the set point determined by the state of the FSP-OP bit (MR13 OP[7]). The values in the registers for the inactive set point will be ignored by the device, and may be changed without affecting device operation.

1.4.4. MR3 Register Information (MA[5:0] = 03H)

OP[7]	OP[6]	OP[5]	OP[4]	OP[3]	OP[2]	OP[1]	OP[0]
DBI-WR	DBI-RD	PDDS			PPRP	WR-PST	PU-CAL

Function	Register Type	Operand	Data	Notes
PU-CAL (Pull-up Calibration Point)	Write-only	OP[0]	0B: VDDQ*0.6 1B: VDDQ*0.5 (default)	1
WR-PST (Write Post-amble length)		OP[1]	0B: WR Post-amble = 0.5*tCK (default) 1B: WR Post-amble = 1.5*tCK (Vendor Specific)	2,3,4
Post Package Repair Protection		OP[2]	0B: PPR Protection Disabled (Default) 1B: PPR Protection Enabled	5
PDDS (Pull-down Drive Strength)		OP[5:3]	000B: RFU 001B: RZQ/1 010B: RZQ/2 011B: RZQ/3 100B: RZQ/4 101B: RZQ/5 110B: RZQ/6 (default) 111B: Reserved	1,2,3
DBI-RD (DBI-Read Enable)		OP[6]	0B: Disabled (default) 1B: Enabled	2,3
DBI-WR (DBI-WR Enable)		OP[7]	0B: Disabled (default) 1B: Enabled	2,3

Notes

1. All values are "typical". The actual value after calibration will be within the specified tolerance for a given voltage and temperature. Re-calibration may be required as voltage and temperature vary.
2. There are two physical registers assigned to each bit of this MR parameter, designated set point 0 and set point 1. Only the registers for the set point determined by the state of the FSP-WR bit (MR13 OP[6]) will be written to with an MRW command to this MR address, or read from with an MRR command to this address.
3. There are two physical registers assigned to each bit of this MR parameter, designated set point 0 and set point 1. The device will operate only according to the values stored in the registers for the active set point, i.e., the set point determined by the state of the FSP-OP bit (MR13 OP[7]). The values in the registers for the inactive set point will be ignored by the device, and may be changed without affecting device operation.
4. Refer to the supplier data sheet for vender specific function. 1.5*tCK apply > 1.6GHz clock.
5. If MR3 OP[2] is set to 1b then PPR protection mode is enabled. The PPR Protection bit is a sticky bit and can only be set to 0b by a power on reset. MR4 OP[4] controls entry to PPR Mode. If PPR protection is enabled then DRAM will not allow writing of 1 to MR4 OP[4].

1.4.5. MR4 Register Information (MA[5:0] = 04H)

OP[7]	OP[6]	OP[5]	OP[4]	OP[3]	OP[2]	OP[1]	OP[0]
TUF	Thermal Offset		PPRE	SR Abort	Refresh Rate		

Function	Register Type	Operand	Data	Notes
Refresh Rate	Read	OP[2:0]	000B: SDRAM Low temperature operating limit exceeded 001B: 4x refresh 010B: 2x refresh 011B: 1x refresh (default) 100B: 0.5x refresh 101B: 0.25x refresh, no de-rating 110B: 0.25x refresh, with de-rating 111B: SDRAM High temperature operating limit exceeded	1,2,3,4, 7,8,9
Self Refresh Abort	Write	OP[3]	0B: Disabled (default) 1B: Enabled	9
PPRE (Post-package repair entry/exit)	Write	OP[4]	0B: Exit PPR mode (default) 1B: Enter PPR mode	5,9
Thermal Offset	Write	OP[6:5]	00B: No offset, 0-5°C gradient (default) 01B: 5°C offset, 5-10°C gradient 10B: 10°C offset, 10-15°C gradient 11B: Reserved	
TUF (Temperature Update Flag)	Read	OP[7]	0B: No change in OP[2:0] since last MR4 read (default) 1B: Change in OP[2:0] since last MR4 read	6,7,8

Notes

- The refresh rate for each MR4-OP[2:0] setting applies to tREFI, tREFIpb, and tREFW. If OP[2]=0B, the device temperature is less or equal to 85°C. Other values require either a longer (2x, 4x) refresh interval at lower temperatures, or a shorter (0.5x, 0.25x) refresh interval at higher temperatures. If OP[2]=1, the device temperature is greater than 85°C.
- At higher temperatures (>85°C), AC timing de-rating may be required. If de-rating is required the LPDDR4-SDRAM will set OP[2:0]=110B. See de-rating timing requirements in the AC Timing section.
- DRAM vendors may or may not report all of the possible settings over the operating temperature range of the device. Each vendor guarantees that their device will work at any temperature within the range using the refresh interval requested by their device.
- The device may not operate properly when OP[2:0]=000B or 111B.
- Post-package repair can be entered or exited by writing to OP[4].
- When OP[7]=1, the refresh rate reported in OP[2:0] has changed since the last MR4 read. A mode register read from MR4 will reset OP[7] to '0'.
- OP[7]=0 at power-up. OP[2:0] bits are undefined at power-up.
- See the section on "Temperature Sensor" for information on the recommended frequency of reading MR4.
- OP[6:3] bits are that can be written in this register. All other bits will be ignored by the DRAM during a MRW to this register

1.4.6. MR5 Register Information (MA[5:0] = 05H)

OP[7]	OP[6]	OP[5]	OP[4]	OP[3]	OP[2]	OP[1]	OP[0]
LPDDR4 Manufacturer ID							

Function	Register Type	Operand	Data	Notes
LPDDR4 Manufacturer ID	Read-only	OP[7:0]	00000110B : SK hynix	

1.4.7. MR6 Register Information (MA[5:0] = 06H)

OP[7]	OP[6]	OP[5]	OP[4]	OP[3]	OP[2]	OP[1]	OP[0]
Revision ID-1							

Function	Register Type	Operand	Data	Notes
LPDDR4 Revision ID-1	Read-only	OP[7:0]	00000000B: A-version 00000001B: B-version	1

Notes

1. Please contact SK hynix office for MR6 code for this device.

1.4.8. MR7 Register Information (MA[5:0] = 07H)

OP[7]	OP[6]	OP[5]	OP[4]	OP[3]	OP[2]	OP[1]	OP[0]
Revision ID-2							

Function	Register Type	Operand	Data	Notes
LPDDR4 Revision ID-1	Read-only	OP[7:0]	00000000B: A-version 00000001B: B-version	1

Notes

1. Please contact SK hynix office for MR7 code for this device.

1.4.9. MR8 Register Information (MA[5:0] = 08H)

OP[7]	OP[6]	OP[5]	OP[4]	OP[3]	OP[2]	OP[1]	OP[0]
IO Width		Density				Type	

Function	Register Type	Operand	Data	Notes
Type	Read-only	OP[1:0]	00B: S16 SDRAM (16n pre-fetch) All Others: Reserved	
Density		OP[5:2]	0000 _B : 2Gb single channel die 0001 _B : 3Gb single channel die 0010 _B : 4Gb single channel die 0011 _B : 6Gb single channel die 0100 _B : 8Gb single channel die 0101 _B : 12Gb single channel die 0110 _B : 16Gb single channel die 1100 _B : 1Gb single channel die All Others: Reserved	
IO Width		OP[7:6]	00B: x16 (per channel) 01B: x8 (per channel) All Others: Reserved	

1.4.10. MR9 Register Information (MA[5:0] = 09H)

OP[7]	OP[6]	OP[5]	OP[4]	OP[3]	OP[2]	OP[1]	OP[0]
Vendor Specific Test Register							

Notes

1. Only 00H should be written to this register.

1.4.11. MR10 Register Information (MA[5:0] = 0AH)

OP[7]	OP[6]	OP[5]	OP[4]	OP[3]	OP[2]	OP[1]	OP[0]
RFU							ZQ Reset

Function	Register Type	Operand	Data	Notes
ZQ Reset	Write-only	OP[0]	0B: Normal Operation (Default) 1B: ZQ Reset	1,2

Notes

1. See the AC Timing tables for calibration latency and timing
2. If the ZQ-pin is connected to VDDQ through RZQ, either the ZQ calibration function or default calibration (via ZQ-Reset) is supported. If the ZQ-pin is connected to VSS, the device operates with default calibration, and ZQ calibration commands are ignored. In both cases, the ZQ connection shall not change after power is applied to the device.

1.4.12. MR11 Register Information (MA[5:0] = 0BH)

OP[7]	OP[6]	OP[5]	OP[4]	OP[3]	OP[2]	OP[1]	OP[0]
RFU	CA ODT			RFU	DQ ODT		

Function	Register Type	Operand	Data	Notes
DQ ODT (DQ Bus Receiver On-Die-Termination)	Write-only	OP[2:0]	000B: Disable (Default) 001B: RZQ/1 010B: RZQ/2 011B: RZQ/3 100B: RZQ/4 101B: RZQ/5 110B: RZQ/6 111B: RFU	1,2,3
CA ODT (CA Bus Receiver On-Die-Termination)		OP[6:4]	0000B: Disable (Default) 0001B: RZQ/1 0010B: RZQ/2 0011B: RZQ/3 0100B: RZQ/4 0101B: RZQ/5 0110B: RZQ/6 0111B: RFU	1,2,3

Notes

1. All values are "typical". The actual value after calibration will be within the specified tolerance for a given voltage and temperature. Re-calibration may be required as voltage and temperature vary.
2. There are two physical registers assigned to each bit of this MR parameter, designated set point 0 and set point 1. Only the registers for the set point determined by the state of the FSP-WR bit (MR13 OP[6]) will be written to with an MRW command to this MR address.
3. There are two physical registers assigned to each bit of this MR parameter, designated set point 0 and set point 1. The device will operate only according to the values stored in the registers for the active set point, i.e., the set point determined by the state of the FSP-OP bit (MR13 OP[7]). The values in the registers for the inactive set point will be ignored by the device, and may be changed without affecting device operation.

1.4.13. MR12 Register Information (MA[5:0] = 0CH)

OP[7]	OP[6]	OP[5]	OP[4]	OP[3]	OP[2]	OP[1]	OP[0]
CBT Mode	VR-CA	VREF(CA)					

Function	Register Type	Operand	Data	Notes
VREF(CA) (VREF(CA) Setting)	Read/Write	OP[5:0]	000000B: -- Thru -- 110010B: See table below All Others: Reserved	1,2,3,5,6
VREF(CA) Range		OP[6]	0B: VREF(CA) Range[0] enabled 1B: VREF(CA) Range[1] enabled (default)	1,2,4,5,6
CBT Mode	Write	OP[7]	0B: Mode1 (Default) 1B: Mode2	7

Notes

1. This register controls the VREF(CA) levels. Refer to Table 3 for actual voltage of VREF(CA).
2. A read to this register places the contents of OP[7:0] on DQ[7:0]. Any RFU bits and unused DQ's shall be set to '0'. See the section on MRR Operation.
3. A write to OP[5:0] sets the internal VREF(CA) level for FSP[0] when MR13 OP[6] = 0B, or sets FSP[1] when MR13 OP[6] = 1B. The time required for VREF(CA) to reach the set level depends on the step size from the current level to the new level. See the section on VREF(CA) training for more information.
4. A write to OP[6] switches the LPDDR4-SDRAM between two internal VREF(CA) ranges. The range (Range[0] or Range[1]) must be selected when setting the VREF(CA) register. The value, once set, will be retained until overwritten, or until the next power-on or RESET event.
5. There are two physical registers assigned to each bit of this MR parameter, designated set point 0 and set point 1. Only the registers for the set point determined by the state of the FSP-WR bit (MR13 OP[6]) will be written to with an MRW command to this MR address, or read from with an MRR command to this address.
6. There are two physical registers assigned to each bit of this MR parameter, designated set point 0 and set point 1. The device will operate only according to the values stored in the registers for the active set point, i.e., the set point determined by the state of the FSP-OP bit (MR13 OP[7]). The values in the registers for the inactive set point will be ignored by the device, and may be changed without affecting device operation.
7. This field can be activated in only Byte Mode: x8. Device.

Table 10 - VREF Settings for Range[0] and Range[1]

Function	Operand	Range[0] Values (% of VDDQ)		Range[1] Values (% of VDDQ)		Notes
VREF Settings for MR12	OP[5:0]	000000B: 15.0%	011010B: 30.5%	000000B: 32.9%	011010B: 48.5%	1,2,3
		000001B: 15.6%	011011B: 31.1%	000001B: 33.5%	011011B: 49.1%	
		000010B: 16.2%	011100B: 31.7%	000010B: 34.1%	011100B: 49.7%	
		000011B: 16.8%	011101B: 32.3%	000011B: 34.7%	011101B: 50.3%	
		000100B: 17.4%	011110B: 32.9%	000100B: 35.3%	011110B: 50.9%	
		000101B: 18.0%	011111B: 33.5%	000101B: 35.9%	011111B: 51.5%	
		000110B: 18.6%	100000B: 34.1%	000110B: 36.5%	100000B: 52.1%	
		000111B: 19.2%	100001B: 34.7%	000111B: 37.1%	100001B: 52.7%	
		001000B: 19.8%	100010B: 35.3%	001000B: 37.7%	100010B: 53.3%	
		001001B: 20.4%	100011B: 35.9%	001001B: 38.3%	100011B: 53.9%	
		001010B: 21.0%	100100B: 36.5%	001010B: 38.9%	100100B: 54.5%	
		001011B: 21.6%	100101B: 37.1%	001011B: 39.5%	100101B: 55.1%	
		001100B: 22.2%	100110B: 37.7%	001100B: 40.1%	100110B: 55.7%	
		001101B: 22.8%	100111B: 38.3%	001101B: 40.7%	100111B: 56.3%	
		001110B: 23.4%	101000B: 38.9%	001110B: 41.3%	101000B: 56.9%	
		001111B: 24.0%	101001B: 39.5%	001111B: 41.9%	101001B: 57.5%	
		010000B: 24.6%	101010B: 40.1%	010000B: 42.5%	101010B: 58.1%	
		010001B: 25.1%	101011B: 40.7%	010001B: 43.1%	101011B: 58.7%	
		010010B: 25.7%	101100B: 41.3%	010010B: 43.7%	101100B: 59.3%	
		010011B: 26.3%	101101B: 41.9%	010011B: 44.3%	101101B: 59.9%	
		010100B: 26.9%	101110B: 42.5%	010100B: 44.9%	101110B: 60.5%	
		010101B: 27.5%	101111B: 43.1%	010101B: 45.5%	101111B: 61.1%	
		010110B: 28.1%	110000B: 43.7%	010110B: 46.1%	110000B: 61.7%	
		010111B: 28.7%	110001B: 44.3%	010111B: 46.7%	110001B: 62.3%	
		011000B: 29.3%	110010B: 44.9%	011000B: 47.3%	110010B: 62.9%	
		011001B: 29.9%	All Others: Reserved	011001B: 47.9%	All Others: Reserved	

Notes

1. These values may be used for MR12 OP[5:0] to set the VREF(CA) levels in the LPDDR4-SDRAM.
2. The range may be selected in the MR12 register by setting OP[6] appropriately.
3. The MR12 registers represents either FSP[0] or FSP[1]. Two frequency-set-points each for CA and DQ are provided to allow for faster switching between terminated and unterminated operation, or between different high-frequency setting which may use different terminations values.

1.4.14. MR13 Register Information (MA[5:0] = 0DH)

OP[7]	OP[6]	OP[5]	OP[4]	OP[3]	OP[2]	OP[1]	OP[0]
FSP-OP	FSP-WR	DMD	RRO	VRCG	VRO	RPRE-TR	CBT

Function	Register Type	Operand	Data	Notes
CBT (Command Bus Training)	Write-Only	OP[0]	0B: Normal Operation (default) 1B: Command Bus Training mode enabled	1
RPT (Read Preamble Training)		OP[1]	0B: Normal Operation (default) 1B: Read Preamble Training mode enabled	
VRO (Vref Output)		OP[2]	0B: Normal Operation (default) 1B: Output the VREF(CA) value on DQ[0] and the VREF(DQ) value on DQ[1]	2
VRCG (VREF Current Generator)		OP[3]	0B: Normal Operation (default) 1B: VREF Fast Response (high current) mode	3
RRO (Refresh Rate Option)		OP[4]	0B: Disable codes 001 and 010 in MR4 OP[2:0] 1B: Enable MR4 OP[2:0]	4,5
DMD (Data Mask Disable)		OP[5]	0B: Data Mask Operation Enabled (default) 1B: Data Mask Operation Disabled	6
FSP-WR (Frequency Set Point Write Enable)		OP[6]	0B: Frequency-Set-Point[0] (default) 1B: Frequency-Set-Point[1]	7
FSP-OP (Frequency Set Point Operation Mode)		OP[7]	0B: Frequency-Set-Point[0] (default) 1B: Frequency-Set-Point[1]	8

Notes

1. A write to set OP[0]=1 causes the LPDDR4-SDRAM to enter the Command bus training mode. When OP[0]=1 and CKE goes LOW, commands are ignored and the contents of CA[5:0] are mapped to the DQ bus. CKE must be brought HIGH before doing a MRW to clear this bit (OP[0]=0) and return to normal operation. See the VREF(CA) training section for more information.
2. When set, the LPDDR4-SDRAM will output the VREF(CA) voltage on DQ[0] and the VREF(DQ) voltage on DQ[1]. Only the "active" frequency-set-point, as defined by MR13 OP[7], will be output on the DQ pins. This function allows an external test system to measure the internal VREF levels.
3. When OP[3]=1, the VREF circuit uses a high-current mode to improve VREF settling time.
4. MR13 OP4 RRO bit is valid only when MR0 OP0 = 1. For LPDDR4 devices with MR0 OP0 = 0, MR4 OP[2:0] bits are not dependent on MR13 OP4.
5. When OP[4] = 0, only 001b and 010b in MR4 OP[2:0] are disabled. LPDDR4 devices must report 011b instead of 001b or 010b in this case. Controller should follow the refresh mode reported by MR4 OP[2:0], regardless of RRO setting. TCSR function does not depend on RRO setting.
6. When enabled (OP[5]=0B) data masking is enabled for the device. When disabled (OP[5]=1B), Masked Write Command is not allowed and it is illegal. See the Data Mask section for more information.
7. FSP-WR determines which frequency-set-point registers are accessed with MRW commands for the following functions: VREF(CA) Setting, VREF(CA) Range, VREF(DQ) Setting, VREF(DQ) Range, CA ODT Enable, CA ODT value, DQ ODT Enable, DQ ODT value, DQ Calibration Point, WL, RL, nWR, Read and Write Preamble, Read postamble, and DBI Enables.
8. FSP-OP determines which frequency-set-point register values are currently used to specify device operation for the following functions: VREF(CA) Setting, VREF(CA) Range, VREF(DQ) Setting, VREF(DQ) Range, CA ODT Enable, CA ODT value, DQ ODT Enable, DQ ODT value, DQ Calibration Point, WL, RL, nWR, Read and Write Preamble, Read postamble, and DBI Enables.

1.4.15. MR14 Register Information (MA[5:0] = 0EH)

OP[7]	OP[6]	OP[5]	OP[4]	OP[3]	OP[2]	OP[1]	OP[0]
RFU	VR(DQ)	VREF(DQ)					

Function	Register Type	Operand	Data	Notes
VREF(DQ) (VREF(DQ) Setting)	Read / Write	OP[5:0]	00000B: -- Thru -- 110010B: See table below All Others: Reserved	1,2,3,5, 6
VREF(DQ) Range		OP[6]	0B: VREF(DQ) Range[0] enabled 1B: VREF(DQ) Range[1] enabled (default)	1,2,4,5, 6

Notes

1. This register controls the VREF(DQ) levels for Frequency-Set-Point[1:0]. Values from either VR(dq)[0] or VR(dq)[1] may be selected by setting OP[6] appropriately.
2. A read (MRR) to this register places the contents of OP[7:0] on DQ[7:0]. Any RFU bits and unused DQ's shall be set to '0'. See the section on MRR Operation.
3. A write to OP[5:0] sets the internal VREF(DQ) level for FSP[0] when MR13 OP[6]=0B, or sets FSP[1] when MR13 OP[6]=1B. The time required for VREF(DQ) to reach the set level depends on the step size from the current level to the new level. See the section on VREF(DQ) training for more information.
4. A write to OP[6] switches the LPDDR4-SDRAM between two internal VREF(DQ) ranges. The range (Range[0] or Range[1]) must be selected when setting the VREF(DQ) register. The value, once set, will be retained until overwritten, or until the next power-on or RESET event.
5. There are two physical registers assigned to each bit of this MR parameter, designated set point 0 and set point 1. Only the registers for the set point determined by the state of the FSP-WR bit (MR13 OP[6]) will be written to with an MRW command to this MR address, or read from with an MRR command to this address.
6. There are two physical registers assigned to each bit of this MR parameter, designated set point 0 and set point 1. The device will operate only according to the values stored in the registers for the active set point, i.e., the set point determined by the state of the FSP-OP bit (MR13 OP[7]). The values in the registers for the inactive set point will be ignored by the device, and may be changed without affecting device operation.

Table 11 - VREF Settings for Range[0] and Range[1]

Function	Operand	Range[0] Values (% of VDDQ)		Range[1] Values (% of VDDQ)		Notes
VREF Settings for MR14	OP[5:0]	000000B: 15.0%	011010B: 30.5%	000000B: 32.9%	011010B: 48.5%	1,2,3
		000001B: 15.6%	011011B: 31.1%	000001B: 33.5%	011011B: 49.1%	
		000010B: 16.2%	011100B: 31.7%	000010B: 34.1%	011100B: 49.7%	
		000011B: 16.8%	011101B: 32.3%	000011B: 34.7%	011101B: 50.3%	
		000100B: 17.4%	011110B: 32.9%	000100B: 35.3%	011110B: 50.9%	
		000101B: 18.0%	011111B: 33.5%	000101B: 35.9%	011111B: 51.5%	
		000110B: 18.6%	100000B: 34.1%	000110B: 36.5%	100000B: 52.1%	
		000111B: 19.2%	100001B: 34.7%	000111B: 37.1%	100001B: 52.7%	
		001000B: 19.8%	100010B: 35.3%	001000B: 37.7%	100010B: 53.3%	
		001001B: 20.4%	100011B: 35.9%	001001B: 38.3%	100011B: 53.9%	
		001010B: 21.0%	100100B: 36.5%	001010B: 38.9%	100100B: 54.5%	
		001011B: 21.6%	100101B: 37.1%	001011B: 39.5%	100101B: 55.1%	
		001100B: 22.2%	100110B: 37.7%	001100B: 40.1%	100110B: 55.7%	
		001101B: 22.8%	100111B: 38.3%	001101B: 40.7%	100111B: 56.3%	
		001110B: 23.4%	101000B: 38.9%	001110B: 41.3%	101000B: 56.9%	
		001111B: 24.0%	101001B: 39.5%	001111B: 41.9%	101001B: 57.5%	
		010000B: 24.6%	101010B: 40.1%	010000B: 42.5%	101010B: 58.1%	
		010001B: 25.1%	101011B: 40.7%	010001B: 43.1%	101011B: 58.7%	
		010010B: 25.7%	101100B: 41.3%	010010B: 43.7%	101100B: 59.3%	
		010011B: 26.3%	101101B: 41.9%	010011B: 44.3%	101101B: 59.9%	
		010100B: 26.9%	101110B: 42.5%	010100B: 44.9%	101110B: 60.5%	
		010101B: 27.5%	101111B: 43.1%	010101B: 45.5%	101111B: 61.1%	
		010110B: 28.1%	110000B: 43.7%	010110B: 46.1%	110000B: 61.7%	
		010111B: 28.7%	110001B: 44.3%	010111B: 46.7%	110001B: 62.3%	
		011000B: 29.3%	110010B: 44.9%	011000B: 47.3%	110010B: 62.9%	
		011001B: 29.9%	All Others: Reserved	011001B: 47.9%	All Others: Reserved	

Notes

1. These values may be used for MR14 OP[5:0] to set the VREF(DQ) levels in the LPDDR4-SDRAM.
2. The range may be selected in the MR14 register by setting OP[6] appropriately.
3. The MR14 registers represents either FSP[0] or FSP[1]. Two frequency-set-points each for CA and DQ are provided to allow for faster switching between terminated and un-terminated operation, or between different high-frequency settings which may use different terminations values.

1.4.16. MR15 Register Information (MA[5:0] = 0FH)

OP[7]	OP[6]	OP[5]	OP[4]	OP[3]	OP[2]	OP[1]	OP[0]
Lower Byte Invert Register for DQ Calibration							

Function	Register Type	Operand	Data	Notes
Lower Byte Invert for DQ Calibration	Write-Only	OP[7:0]	The following values may be written for any operand OP[7:0], and will be applied to the corresponding DQ locations DQ[7:0] within a byte lane: 0B: Do not invert 1B: Invert the DQ Calibration patterns in MR32 and MR40 Default value for OP[7:0]=55H	1,2,3

Notes

1. This register will invert the DQ Calibration pattern found in MR32 and MR40 for any single DQ, or any combination of DQ's. Example: If MR15 OP[7:0]=00010101B, then the DQ Calibration patterns transmitted on DQ[7,6,5,3,1] will not be inverted, but the DQ Calibration patterns transmitted on DQ[4,2,0] will be inverted.
2. DMI[0] is not inverted, and always transmits the "true" data contained in MR32/MR40.
3. No Data Bus Inversion (DBI) function is enacted during DQ Read Calibration, even if DBI is enabled in MR3-OP[6].

Table 12 - MR15 Invert Register Pin Mapping

Pin	DQ0	DQ1	DQ2	DQ3	DMI0	DQ4	DQ5	DQ6	DQ7
MR15	OP0	OP1	OP2	OP3	No-invert	OP4	OP5	OP6	OP7

1.4.17. MR16 Register Information (MA[5:0] = 10H)

OP[7]	OP[6]	OP[5]	OP[4]	OP[3]	OP[2]	OP[1]	OP[0]
PASR Bank Mask							

Function	Register Type	Operand	Data	Notes
Bank[7:0] Mask	Write-only	OP[7:0]	0B: Bank Refresh enabled (default) : Unmasked 1B: Bank Refresh disabled : Masked	1

OP[n]	Bank Mask	8-Bank SDRAM
0	xxxxxx1	Bank 0
1	xxxxx1x	Bank 1
2	xxxx1xx	Bank 2
3	xxx1xxx	Bank 3
4	xx1xxxx	Bank 4
5	xx1xxxx	Bank 5
6	x1xxxxx	Bank 6
7	1xxxxxx	Bank 7

Notes

1. When a mask bit is asserted (OP[n]=1), refresh to that bank is disabled.
2. PASR bank masking is on a per channel basis.

1.4.18. MR17 Register Information (MA[5:0] = 11H)

OP[7]	OP[6]	OP[5]	OP[4]	OP[3]	OP[2]	OP[1]	OP[0]
PASR Segment Mask							

Function	Register Type	Operand	Data	Notes
PASR Segment Mask	Write-only	OP[7:0]	0B: Segment Refresh enabled (default) 1B: Segment Refresh disabled	1

Segment	OP[n]	Segment Mask	1Gb per Channel	2Gb per channel	3Gb per channel	4Gb per channel	6Gb per channel	8Gb per channel	12Gb per channel	16Gb per channel		
			R12:R10	R13:R11	R14:R12	R14:R12	R15:R13	R15:R13	R16:R14	R16:R14	R17:R15	R16:R14
			(Byte Mode)	(Byte Mode)	(Byte Mode)	(Byte Mode)	(Byte Mode)	(Byte Mode)	(Byte Mode)	(Byte Mode)	(Byte Mode)	(Byte Mode)
0	0	xxxxxx1	000B									
1	1	xxxxx1x	001B									
2	2	xxxxx1xx	010B									
3	3	xxx1xxx	011B									
4	4	xx1xxxx	100B									
5	5	xx1xxxxx	101B									
6	6	x1xxxxxx	110 _B	110 _B	Not Allowed	110 _B	Not Allowed	110 _B	Not Allowed	110 _B		
7	7	1xxxxxxx	111 _B	111 _B		111 _B		111 _B		111 _B	111 _B	

Notes

1. This table indicates the range of row addresses in each masked segment. "X" is don't care for a particular segment.
2. PASR segment-masking is on a per-channel basis.
3. For 3Gb, 6Gb and 12Gb per channel densities, OP[7:6] must always be LOW (=00_B).

1.4.19. MR18 Register Information (MA[5:0] = 12H)

OP[7]	OP[6]	OP[5]	OP[4]	OP[3]	OP[2]	OP[1]	OP[0]
DQS Oscillator Count - LSB							

Function	Register Type	Operand	Data	Notes
DQS Oscillator (WR Training DQS Oscillator)	Read-only	OP[7:0]	0:255 LSB DRAM DQS Oscillator Count	1,2,3

Notes

- MR18 reports the LSB bits of the DRAM DQS Oscillator count. The DRAM DQS Oscillator count value is used to train DQS to the DQ data valid window. The value reported by the DRAM in this mode register can be used by the memory controller to periodically adjust the phase of DQS relative to DQ.
- Both MR18 and MR19 must be read (MRR) and combined to get the value of the DQS Oscillator count.
- A new MPC [Start DQS Oscillator] should be issued to reset the contents of MR18/MR19.

1.4.20. MR19 Register Information (MA[5:0] = 13H)

OP[7]	OP[6]	OP[5]	OP[4]	OP[3]	OP[2]	OP[1]	OP[0]
DQS Oscillator Count - MSB							

Function	Register Type	Operand	Data	Notes
DQS Oscillator (WR Training DQS Oscillator)	Read-only	OP[7:0]	0:255 MSB DRAM DQS Oscillator Count	1,2,3

Notes

1. MR19 reports the MSB bits of the DRAM DQS Oscillator count. The DRAM DQS Oscillator count value is used to train DQS to the DQ data valid window. The value reported by the DRAM in this mode register can be used by the memory controller to periodically adjust the phase of DQS relative to DQ.
2. Both MR18 and MR19 must be read (MRR) and combined to get the value of the DQS Oscillator count.
3. A new MPC [Start DQS Oscillator] should be issued to reset the contents of MR18/MR19.

1.4.21. MR20 Register Information (MA[5:0] = 14H)

OP[7]	OP[6]	OP[5]	OP[4]	OP[3]	OP[2]	OP[1]	OP[0]
Upper Byte Invert Register for DQ Calibration							

Function	Register Type	Operand	Data	Notes
Upper Byte Invert for DQ Calibration	Write-Only	OP[7:0]	<p>The following values may be written for any operand OP[7:0], and will be applied to the corresponding DQ locations DQ[15:8] within a byte lane:</p> <p>0B: Do not invert 1B: Invert the DQ Calibration patterns in MR32 and MR40</p> <p>Default value for OP[7:0]=55H</p>	1,2

Notes

1. This register will invert the DQ Calibration pattern found in MR32 and MR40 for any single DQ, or any combination of DQ's. Example: If MR20 OP[7:0]=00010101B, then the DQ Calibration patterns transmitted on DQ[15,14,13,11,9] will not be inverted, but the DQ Calibration patterns transmitted on DQ[12,10,8] will be inverted.
2. DMI[1] is not inverted, and always transmits the "true" data contained in MR32/MR40.
3. No Data Bus Inversion (DBI) function is enacted during DQ Read Calibration, even if DBI is enabled in MR3-OP[6].

Table 13 - MR20 Invert Register Pin Mapping

Pin	DQ8	DQ9	DQ10	DQ11	DMI1	DQ12	DQ13	DQ14	DQ15
MR20	OP0	OP1	OP2	OP3	No-invert	OP4	OP5	OP6	OP7

1.4.22. MR21 Register Information (MA[5:0] = 15H)

OP[7]	OP[6]	OP[5]	OP[4]	OP[3]	OP[2]	OP[1]	OP[0]
Vendor Specific Mode Register							

1.4.23. MR22 Register Information (MA[5:0] = 16H)

OP[7]	OP[6]	OP[5]	OP[4]	OP[3]	OP[2]	OP[1]	OP[0]
ODTD for x8_2ch(Byte Mode)		ODTD-CA	ODTE-CS	ODTE-CK	SOC ODT		

Function	Register Type	Operand	Data	Notes
SoC ODT (Controller ODT Value for VOH calibration)	Write	OP[2:0]	000B: Disable (Default) 001B: RZQ/1(illegal if MR3 OP[0]=0B) 010B: RZQ/2 011B: RZQ/3(illegal if MR3 OP[0]=0B) 100B: RZQ/4 101B: RZQ/5(illegal if MR3 OP[0]=0B) 110B: RZQ/6(illegal if MR3 OP[0]=0B) 111B: RFU	1,2,3
ODTE-CK (CK ODT enabled for non-terminating rank)		OP[3]	ODT bond PAD is ignored 0B: ODT-CK Enable (Default) 1B: ODT-CK Disable	2,3,4
ODTE-CS (CS ODT enable for non-terminating rank)		OP[4]	ODT bond PAD is ignored 0B: ODT-CS Enable (Default) 1B: ODT-CS Disable	2,3,4
ODTD-CA (CA ODT termination disable)		OP[5]	ODT bond PAD is ignored 0B: ODT-CA Enable (Default) 1B: ODT-CA Disable	2,3,4
x8ODTD[7:0] (CA/CK ODT termination disable, [7:0] Byte select)		OP[6]	x8_2ch only, [7:0] Byte selected Device 0 _B : ODT-CA Obeys ODT_CA bond pad (default) 1 _B : ODT-CS/CA/CLK Disabled	4
x8ODTD[15:8] (CA/CK ODT termination disable, [15:8] Byte select)		OP[7]	x8_2ch only, [15:8] Byte selected Device 0 _B : ODT-CA Obeys ODT_CA bond pad (default) 1 _B : ODT-CS/CA/CLK Disabled	4

Notes

1. All values are "typical".
2. There are two physical registers assigned to each bit of this MR parameter, designated set point 0 and set point 1. Only the registers for the set point determined by the state of the FSP-WR bit (MR13 OP[6]) will be written to with an MRW command to this MR address, or read from with an MRR command to this address.
3. There are two physical registers assigned to each bit of this MR parameter, designated set point 0 and set point 1. The device will operate only according to the values stored in the registers for the active set point, i.e., the set point determined by the state of the FSP-OP bit (MR13 OP[7]). The values in the registers for the inactive set point will be ignored by the device, and may be changed without affecting device operation.
4. The ODT_CA pin is ignored by LPDDR4X devices. The ODT_CA pin shall be connected to either VDD2 or VSS. CA/ CS/ CK ODT is fully controlled through MR11 and MR22. Before enabling CA termination via MR11, all ranks should have appropriate MR22 termination settings programmed.

Table 14 - LPDDR4x Byte Mode Device (MR11 OP[6:4] ≠ 000B Case)

MR22	ODTD Byte Mode		ODT CA	ODT CS	ODT CK	ODT PAD ignore					
	OP[7]	OP[6]				CA		CS		CK	
						Lower Byte	Upper Byte	Lower Byte	Upper Byte	Lower Byte	Upper Byte
LPD4x	0	0	0	0	0	T	T	T	T	T	T
	0	0	0	0	1	T	T	T	T		
	0	0	0	1	0	T	T			T	T
	0	0	0	1	1	T	T				
	0	0	1	0	0			T	T	T	T
	0	0	1	0	1			T	T		
	0	0	1	1	0					T	T
	0	0	1	1	1						
	0	1	0	0	0		T		T		T
	0	1	0	0	1		T		T		
	0	1	0	1	0		T				T
	0	1	0	1	1		T				
	0	1	1	0	0				T		T
	0	1	1	0	1				T		
	0	1	1	1	0						T
	0	1	1	1	1						
	1	0	0	0	0	T		T		T	
	1	0	0	0	1	T		T			
	1	0	0	1	0	T				T	
	1	0	0	1	1	T					
1	0	1	0	0			T		T		
1	0	1	0	1			T				
1	0	1	1	0					T		
1	0	1	1	1							

Notes

1. T Means "terminated" condition. Blank is "unterminated".

1.4.24. MR23 Register Information (MA[5:0] = 17H)

OP[7]	OP[6]	OP[5]	OP[4]	OP[3]	OP[2]	OP[1]	OP[0]
DQS interval timer run time setting							

Function	Register Type	Operand	Data	Notes
DQS interval timer run time	Write-Only	OP[7:0]	00000000B: DQS timer stops via MPC Command (Default) 00000001B: DQS timer stops automatically at 16th clocks after timer start 00000010B: DQS timer stops automatically at 32nd clocks after timer start 00000011B: DQS timer stops automatically at 48th clocks after timer start 00000100B: DQS timer stops automatically at 64th clocks after timer start ----- Thru ----- 00111111B: DQS timer stops automatically at (63X16)th clocks after timer start 01XXXXXXB: DQS timer stops automatically at 2048th clocks after timer start 10XXXXXXB: DQS timer stops automatically at 4096th clocks after timer start 11XXXXXXB: DQS timer stops automatically at 8192nd clocks after timer start	1, 2

Note

1. MPC command with OP[6:0]=1001101B (Stop DQS Interval Oscillator) stops DQS interval timer in case of MR23 OP[7:0] = 00000000B.
2. MPC command with OP[6:0]=1001101B (Stop DQS Interval Oscillator) is illegal with non-zero values in MR23 OP[7:0].

1.4.25. MR24 Register Information (MA[5:0] = 18H)

OP[7]	OP[6]	OP[5]	OP[4]	OP[3]	OP[2]	OP[1]	OP[0]
TRR Mode	TRR Mode Bank Address			Unlimited	MAC Value		

Function	Register Type	Operand	Data	Notes
MAC Value	Read-Only	OP[2:0]	000B: Unknown when bit OP3 =0 (note 1) Unlimited when bit OP3=1 (note 2) 001B: 700K 010B: 600K 011B: 500K 100B: 400K 101B: 300K 110B: 200K 111B: Reserved	
Unlimited MAC		OP[3]	0B: OP[2:0] define MAC value 1B: Unlimited MAC value (note 2, note 3)	
TRR Mode BAn	Write-Only	OP[6:4]	000B: Bank 0 001B: Bank 1 010B: Bank 2 011B: Bank 3 100B: Bank 4 101B: Bank 5 110B: Bank 6 111B: Bank 7	
TRR Mode		OP[7]	0B: Disabled (default) 1B: Enabled	

Notes

1. Unknown means that the device is not tested for tMAC and pass/fail value in unknown.
2. There is no restriction to number of activates.
3. MR24 OP [2:0] is set to zero.

1.4.26. MR25 Register Information (MA[5:0] = 19H)

OP[7]	OP[6]	OP[5]	OP[4]	OP[3]	OP[2]	OP[1]	OP[0]
Bank 7	Bank 6	Bank 5	Bank 4	Bank 3	Bank 2	Bank 1	Bank 0

Function	Register Type	Operand	Data	Notes
PPR Resource	Read-Only	OP[7:0]	0B: PPR Resource is not available 1B: PPR Resource is available	

1.4.27. MR26:31 Register Information (MA[5:0] = 1AH:1FH)

OP[7]	OP[6]	OP[5]	OP[4]	OP[3]	OP[2]	OP[1]	OP[0]
Reserved							

1.4.28. MR32 Register Information (MA[5:0] = 20H)

OP[7]	OP[6]	OP[5]	OP[4]	OP[3]	OP[2]	OP[1]	OP[0]
DQ Calibration Pattern "A" (default = 5AH)							

Function	Register Type	Operand	Data	Notes
Return DQ Calibration Pattern MR32 + MR40	Write	OP[7:0]	<p>XB: An MPC command with OP[6:0]=1000011B causes the device to return the DQ Calibration Pattern contained in this register and (followed by) the contents of MR40. A default pattern "5AH" is loaded at power-up or RESET, or the pattern may be overwritten with a MRW to this register. The contents of MR15 and MR20 will invert the data pattern for a given DQ (See MR15 for more information)</p>	

1.4.29. MR33:39 Register Information (MA[5:0] = 21H:27H)

OP[7]	OP[6]	OP[5]	OP[4]	OP[3]	OP[2]	OP[1]	OP[0]
Do Not Use							

1.4.30. MR40 Register Information (MA[5:0] = 28H)

OP[7]	OP[6]	OP[5]	OP[4]	OP[3]	OP[2]	OP[1]	OP[0]
DQ Calibration Pattern "B" (default = 3CH)							

Function	Register Type	Operand	Data	Notes
Return DQ Calibration Pattern MR32 + MR40	Write-Only	OP[7:0]	XB: A default pattern "3CH" is loaded at power-up or RESET, or the pattern may be overwritten with a MRW to this register. See MR32 for more information.	1,2,3,4

Notes

1. The pattern contained in MR40 is concatenated to the end of MR32 and transmitted on DQ[15:0] and DMI[1:0] when DQ Read Calibration is initiated via a MPC command. The pattern transmitted serially on each data lane, organized "little endian" such that the low-order bit in a byte is transmitted first. If the data pattern in MR40 is 27H, then the first bit transmitted will be a '1', followed by '1', '1', '0', '0', '1', '0', and '0'. The bit stream will be 00100111B.
2. MR15 and MR20 may be used to invert the MR32/MR40 data patterns on the DQ pins. See MR15 and MR22 for more information. Data is never inverted on the DMI[1:0] pins.
3. The data pattern is not transmitted on the DMI[1:0] pins if DBI-RD is disabled via MR3-OP[6].
4. No Data Bus Inversion (DBI) function is enacted during DQ Read Calibration, even if DBI is enabled in MR3-OP[6].

2. LPDDR4 Command Definitions and Timing Diagrams

2.1. Activate Command

The ACTIVATE command is composed of two consecutive commands, Activate-1 command and Activate-2. Activate-1 command is issued by holding CS HIGH, CA0 HIGH and CA1 LOW at the first rising edge of the clock and Activate-2 command issued by holding CS HIGH, CA0 HIGH and CA1 HIGH at the first rising edge of the clock. The bank addresses BA0, BA1 and BA2 are used to select desired bank. Row addresses are used to determine which row to activate in the selected bank. The ACTIVATE command must be applied before any READ or WRITE operation can be executed. The device can accept a READ or WRITE command at t_{RCD} after the ACTIVATE command is issued. After a bank has been activated it must be precharged before another ACTIVATE command can be applied to the same bank. The bank active and precharge times are defined as t_{RAS} and t_{RP} respectively. The minimum time interval between ACTIVATE commands to the same bank is determined by the RAS cycle time of the device (t_{RC}). The minimum time interval between ACTIVATE commands to different banks is t_{RRD} .

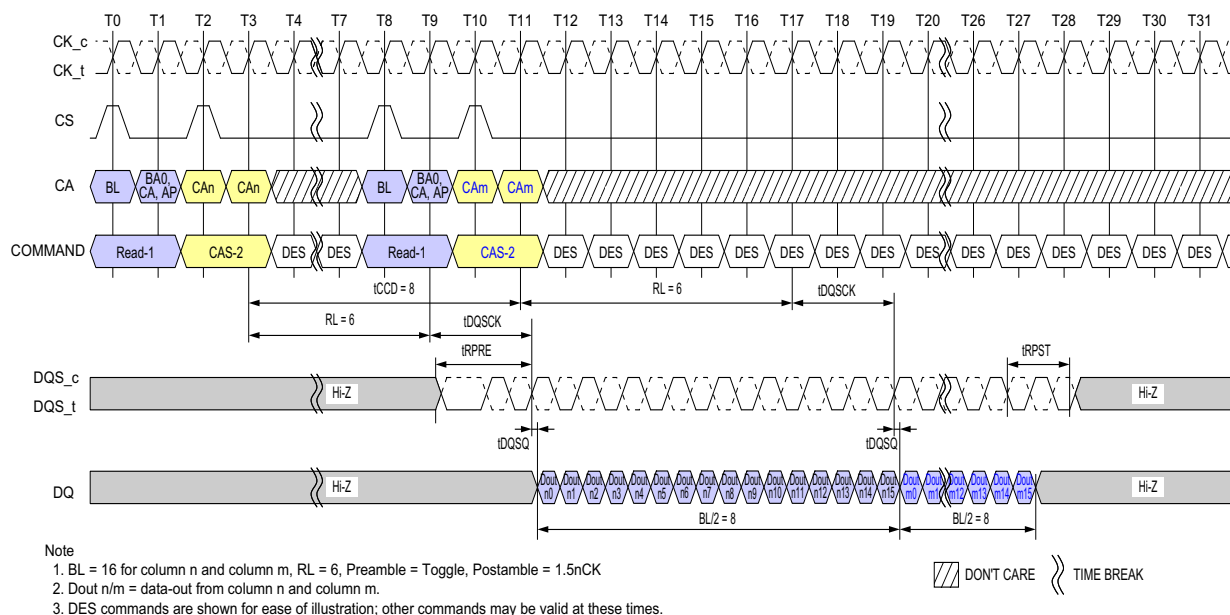

Figure 5 - Activate Command

2.2. 8-Bank Device Operation

Certain restrictions on operation of the 8-bank LPDDR4 devices must be observed. There are two rules: One rule restricts the number of sequential ACTIVATE commands that can be issued; the other provides more time for RAS precharge for a PRECHARGE ALL command. The rules are as follows:

8 bank device Sequential Bank Activation Restriction: No more than 4 banks may be activated (or refreshed, in the case of REFpb) in a rolling tFAW window. The number of clocks in a tFAW period is dependent upon the clock frequency, which may vary. If the clock frequency is not changed over this period, converting clocks is done by dividing tFAW[ns] by tCK[ns], and rounding up to the next integer value. As an example of the rolling window, if $\text{RU}(t_{\text{FAW}}/t_{\text{CK}})$ is 10 clocks, and an ACTIVATE command is issued in clock n, no more than three further ACTIVATE commands can be issued at or between clock n + 1 and n + 9. REFpb also counts as

bank activation for purposes of tFAW. If the clock frequency is changed during the tFAW period, the rolling tFAW window may be calculated in clock cycles by adding up the time spent in each clock period. The tFAW requirement is met when the previous n clock cycles exceeds the tFAW time.

The 8-Bank Device Precharge-All Allowance: tRP for a PRECHRG ALL command must equal tRPab, which is greater than tRPpb.

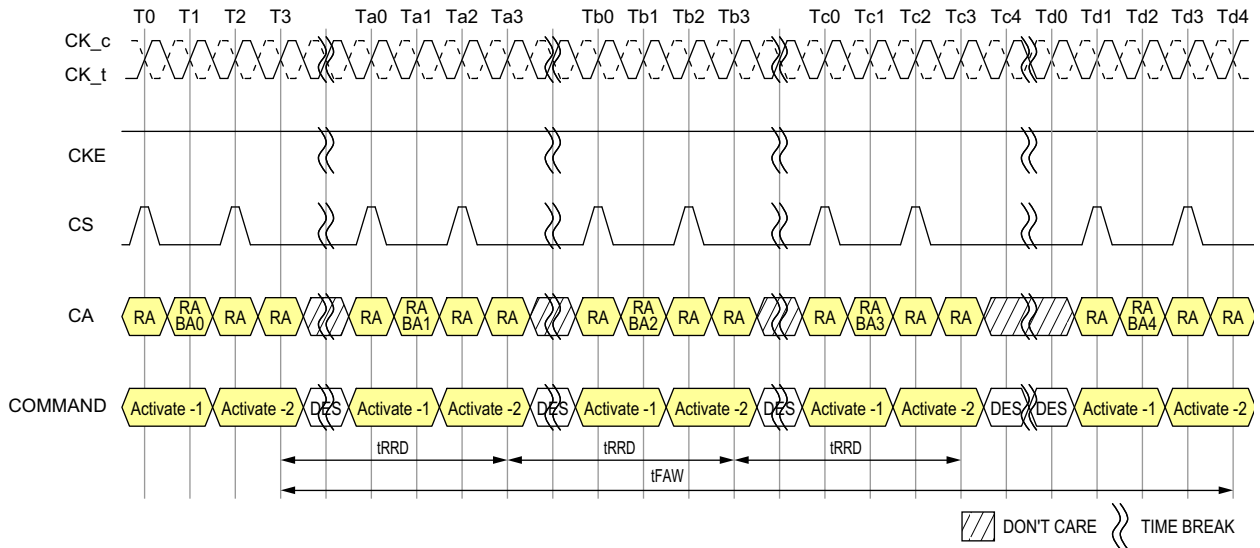

Figure 6 - tFAW Timing

2.3. Core Timing
Table 15 - Core AC timing for x16 mode

Parameter	Symbol	min max	Data Rate							Unit	Note	
			533	1066	1600	2133	2667	3200	3733			4266
ACTIVATE-to-ACTIVATE command period (same bank)	tRC	MIN	tRAS + tRPab (with all bank precharge) tRAS + tRPpb (with per bank precharge)							ns		
Minimum Self RefreshTime (Entry to Exit)	tSR	MIN	max(15ns, 3nCK)							ns		
Self Refresh exit to next valid command delay	tXSR	MIN	max(tRFCab + 7.5ns, 2nCK)							ns		
Exit Power-Down to next valid command delay	tXP	MIN	max(7.5ns, 5nCK)							ns		
CAS-to-CAS delay	tCCD	MIN	8							tCK(avg)	2	
CAS to CAS delay Masked Write w/ECC	tCCDMW	min	4 * tCCD							tCK(avg)		
Internal READ to PRECHARGE command delay	tRTP	MIN	max(7.5ns, 8nCK)							ns		
RAS-to-CAS delay	tRCD	MIN	max(18ns, 4nCK)							ns		
Row precharge time (single bank)	tRPpb	MIN	max(18ns, 4nCK)							ns		
Row precharge time (all banks)	tRPab	MIN	max(21ns, 4nCK)							ns		
Row active time	tRAS	MIN	max(42ns, 3nCK)							ns		
		MAX	min(9 * tREFI * Refresh Rate, 70.2us)							us	3	
WRITE recovery time	tWR	MIN	max(18ns, 6nCK)							ns		
WRITE-to-READ delay	tWTR	MIN	max(10ns, 8nCK)							ns		
Active bank-A to active bank-B	tRRD	MIN	max(10ns, 4nCK)							max(7.5ns, 4nCK)	ns	
Precharge to Precharge Delay	tPPD	MIN	4							tCK(avg)	1	
Four-bank ACTIVATE window	tFAW	MIN	40							30	ns	

Notes

1. Precharge to precharge timing restriction does not apply to Auto-Precharge commands.
2. The value is based on BL16. For BL32 need additional 8 tCK (avg) delay.
3. Refresh Rate is specified by MR4 OP[2:0].

Table 16 - Core AC Timing for Byte (x8) mode

Parameter	Symbol	min max	Data Rate							Unit	Note
			533	1066	1600	2133	2667	3200	3733		
WRITE recovery time	tWR	MIN	max(20ns, 6nCK)							ns	
WRITE-to-READ delay	tWTR	MIN	max(12ns, 8nCK)							ns	

Notes

1. The rest of the Core AC timing is the same as x16 mode.

2.4. Read and Write Access Operations

After a bank has been activated, a read or write command can be executed. This is accomplished by asserting CKE asynchronously, with CS and CA[5:0] set to the proper state (see Command Truth Table) at a rising edge of CK.

The LPDDR4-SDRAM provides a fast column access operation. A single Read or Write command will initiate a burst read or write operation, where data is transferred to/from the DRAM on successive clock cycles. Burst interrupts are not allowed, but the optimal burst length may be set on the fly (see command truth table).

2.5. Read Preamble and Postamble

The DQS strobe for the LPDDR4-SDRAM requires a pre-amble prior to the first latching edge (the rising edge of DQS_t with DATA "valid"), and it requires a post-amble after the last latching edge. The pre-amble and post-amble lengths are set via mode register writes (MRW).

For READ operations the pre-amble is $2 * tCK$, but the pre-amble is static (no-toggle) or toggling, selectable via mode register.

LPDDR4 will have a DQS Read post-ample of $0.5 * tCK$ (or extended to $1.5 * tCK$). Standard DQS postamble will be $0.5 * tCK$ driven by the DRAM for Reads. A mode register setting instructs the DRAM to drive an additional (extended) one cycle DQS Read post-ample. The drawings below show examples of DQS Read post-ample for both standard (tRPST) and extended (tRPSTE) post-ample operation.

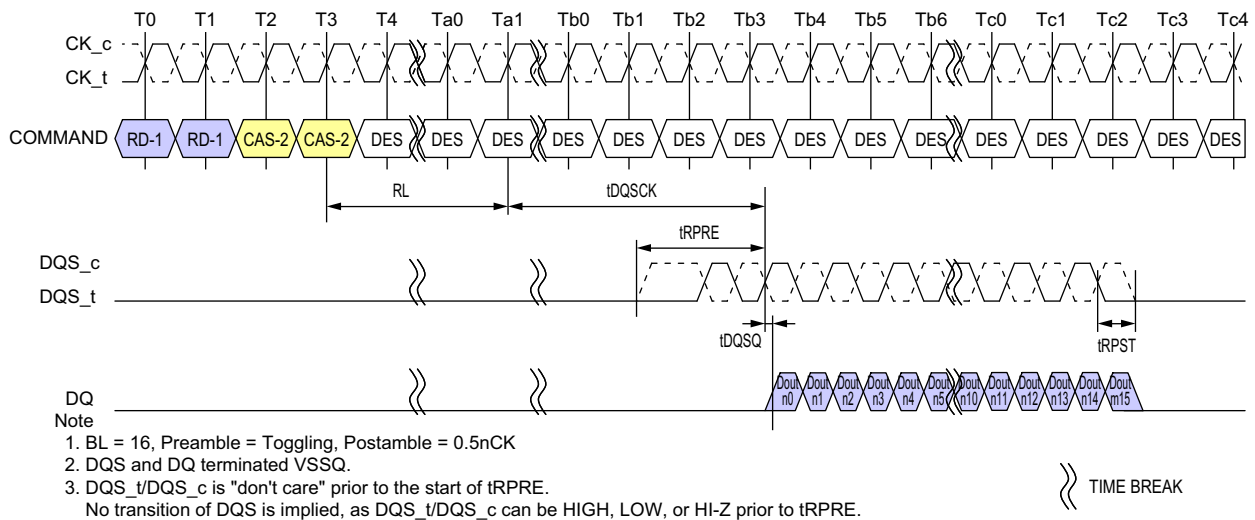

Figure 7 - DQS Read Preamble and Postamble: Toggling Preamble and 0.5nCK Postamble

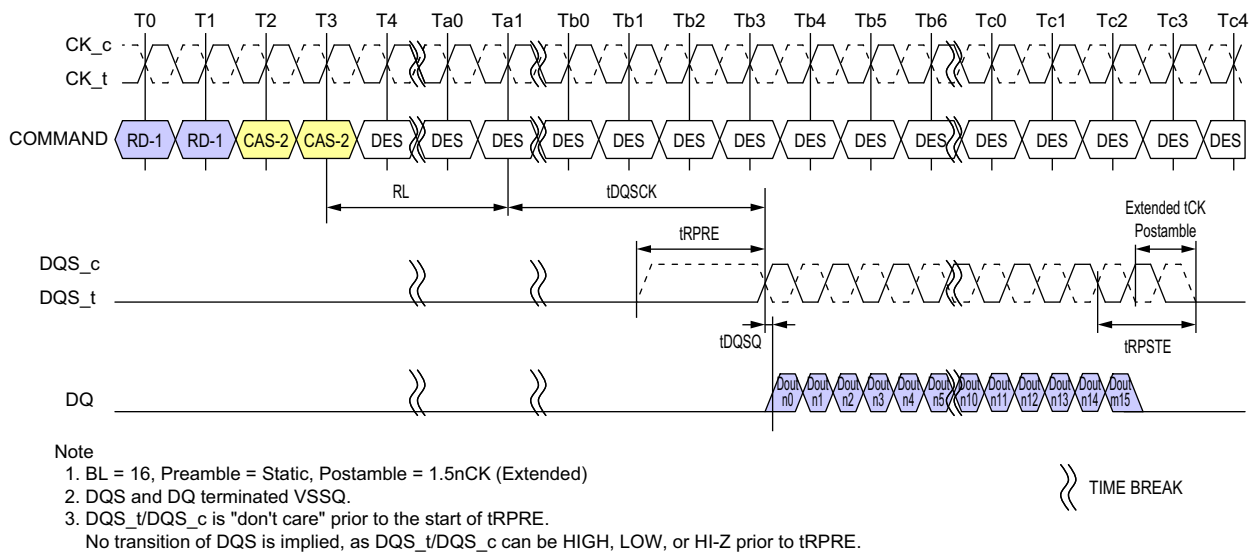

Figure 8 - DQS Read Preamble and Postamble: Static Preamble and 1.5nCK Postamble

2.6. Burst Read Operation

A burst Read command is initiated with CKE, CS, and CA[5:0] asserted to the proper state at the rising edge of CK, as defined by the Command Truth Table. The command address bus inputs determine the starting column address for the burst. The two low-order address bits are not transmitted on the CA bus and are implied to be "0", so that the starting burst address is always a multiple of four (ex. 0x0, 0x4, 0x8, 0xC). The read latency (RL) is defined from the last rising edge of the clock that completes a read command (Ex: the second rising edge of the CAS-2 command) to the rising edge of the clock from which the tDQSK delay is measured. The first valid data is available $RL * tCK + tDQSK + tDQSQ$ after the rising edge of Clock that completes a read command. The data strobe output is driven tRPRE before the first valid rising strobe edge. The first data-bit of the burst is synchronized with the first valid (i.e. post-preamble) rising edge of the data strobe. Each subsequent dataout appears on each DQ pin, edge-aligned with the data strobe. At the end of a burst the DQS signals are driven for another half cycle post-amble, or for a 1.5-cycle postamble if the programmable post-amble bit is set in the mode register. The RL is programmed in the mode registers. Pin timings for the data strobe are measured relative to the cross-point of DQS_t and DQS_c.

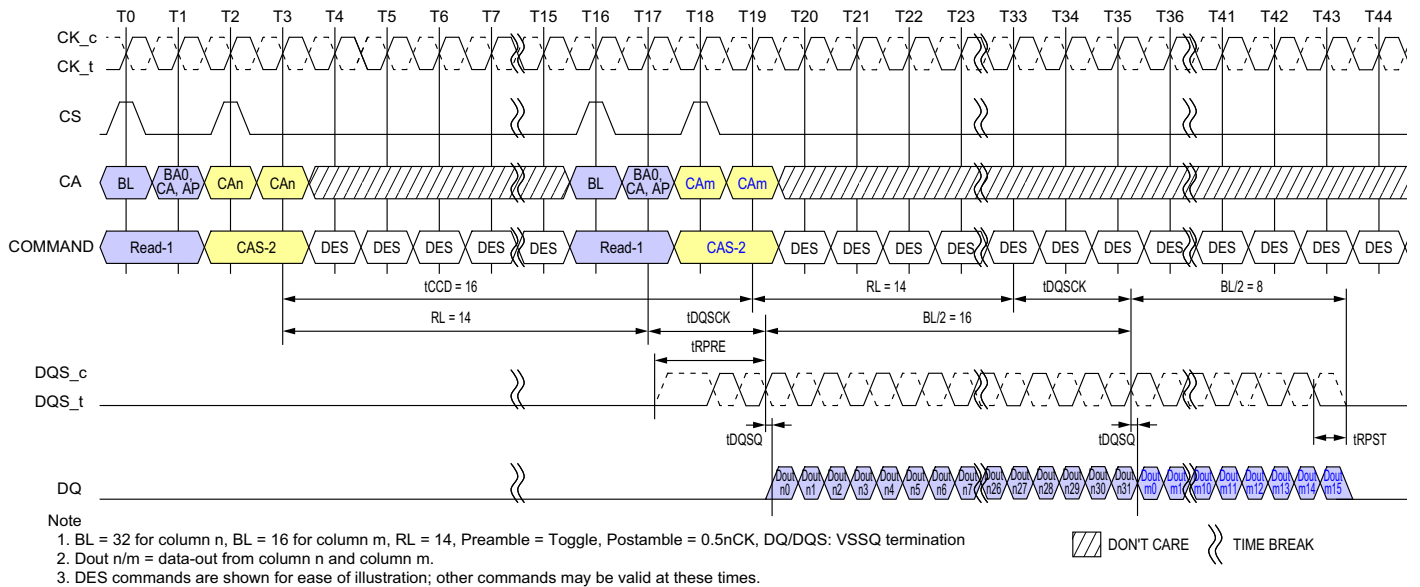
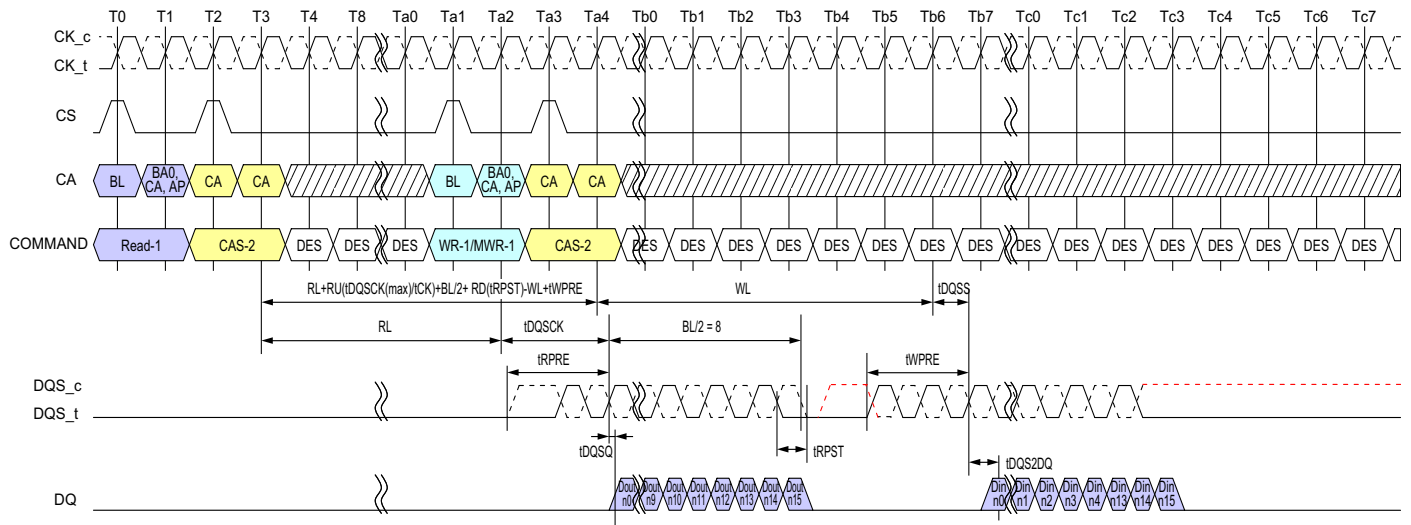

Figure 9 - Burst Read Timing



- Note
1. BL=16, Read Preamble = Toggle, Read Postamble = 0.5nCK, Write Preamble = 2nCK, Write Postamble = 0.5nCK, DQ/DQS: VSSQ termination
 2. Dout n = data-out from column n and Din n = data-in to column n
 3. DES commands are shown for ease of illustration; other commands may be valid at these times.

Figure 10 - Burst Read followed by Burst Write or Burst Mask Write

The minimum time from a Burst Read command to a Write or MASK WRITE command is defined by the read latency (RL) and the burst length (BL). Minimum READ-to-WRITE or MASK WRITE latency is $RL + RU(tDQSK(max)/tCK) + BL/2 + RD(tRPST) - WL + tWPRE$.

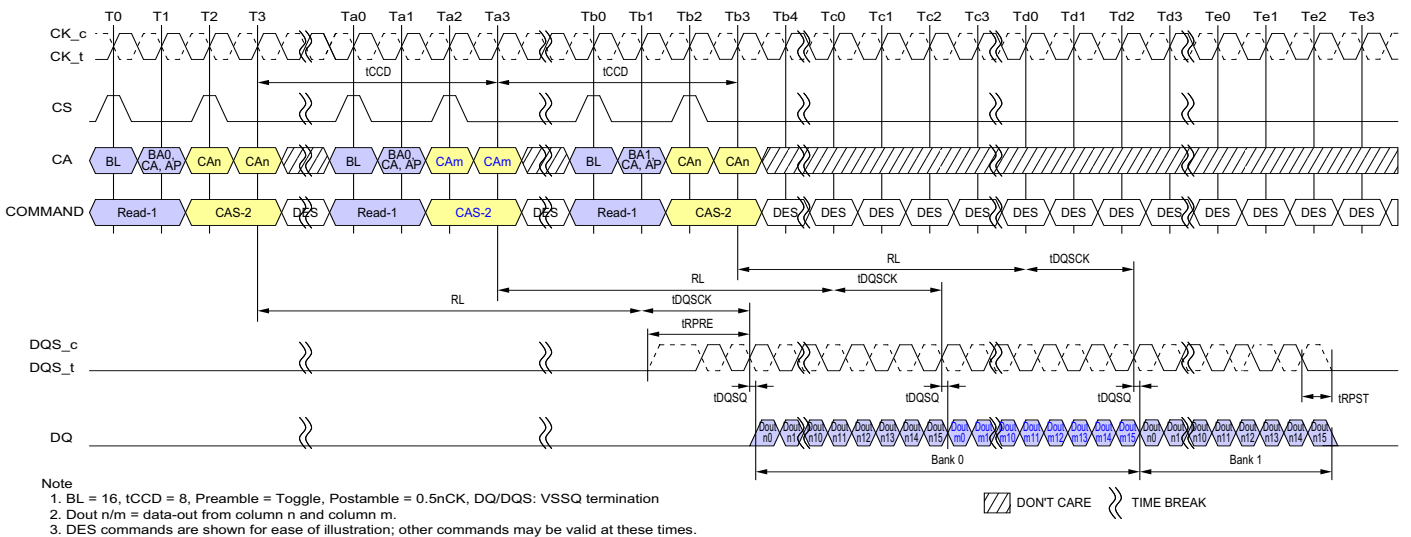

- Note
1. BL = 16, tCCD = 8, Preamble = Toggle, Postamble = 0.5nCK, DQ/DQS: VSSQ termination
 2. Dout n/m = data-out from column n and column m.
 3. DES commands are shown for ease of illustration; other commands may be valid at these times.

▨ DONT CARE ⋈ TIME BREAK

Figure 11 - Seamless Burst Read

The seamless Burst READ operation is supported by placing a READ command at every tCCD(min) interval for BL16 (or every 2 x tCCD for BL32). The seamless Burst READ can access any open bank.

2.7. Read Timing

The read timing is shown in following figure.

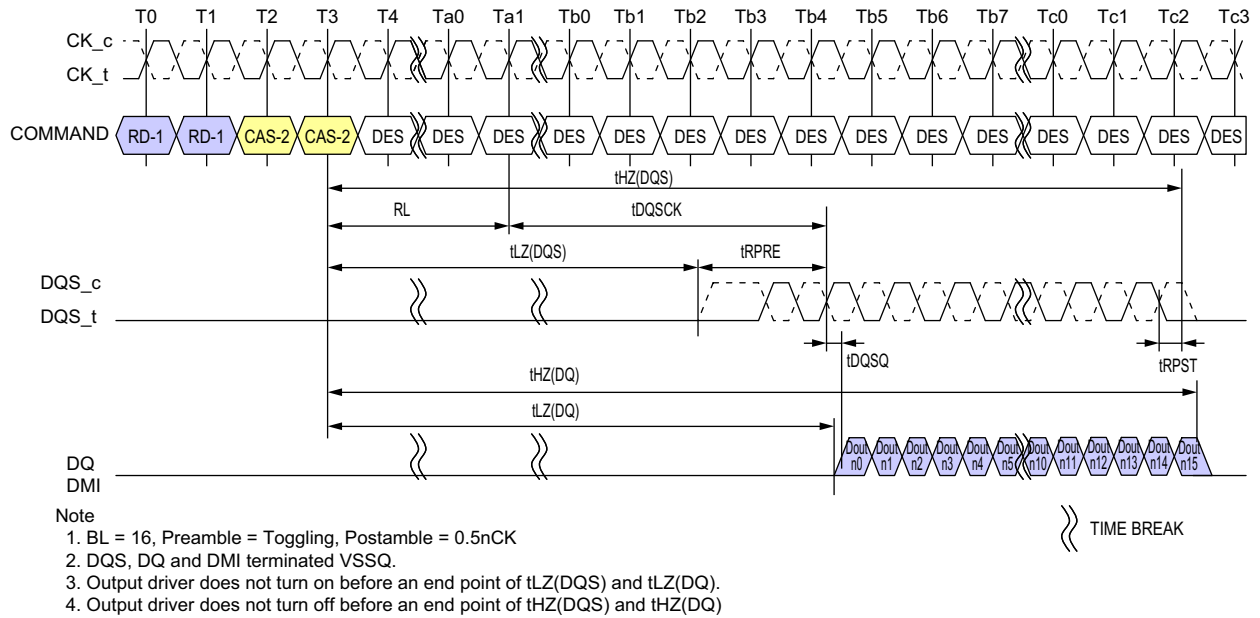
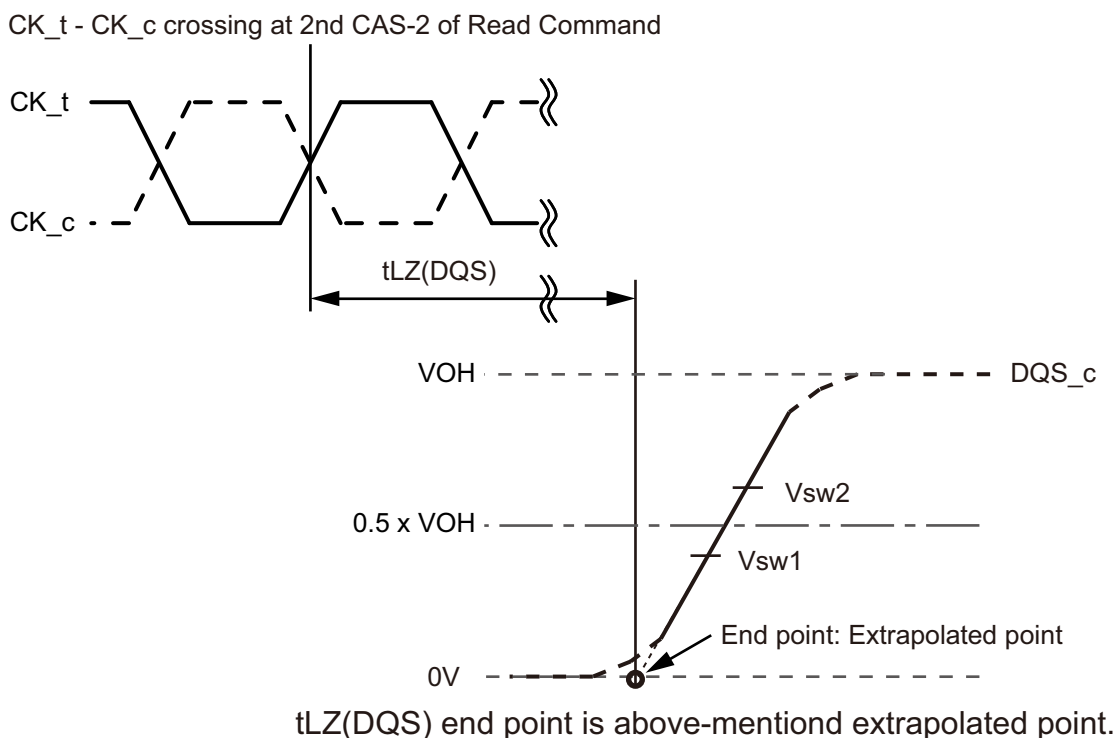

Figure 12 - Read Timing

2.8. tLZ(DQS), tLZ(DQ), tHZ(DQS), tHZ(DQ) Calculation

tHZ and tLZ transitions occur in the same time window as valid data transitions. These parameters are referenced to a specific voltage level that specifies when the device output is no longer driving tHZ(DQS) and tHZ(DQ), or begins driving tLZ(DQS), tLZ(DQ). This section shows a method to calculate the point when the device is no longer driving tHZ(DQS) and tHZ(DQ), or begins driving tLZ(DQS), tLZ(DQ), by measuring the signal at two different voltages. The actual voltage measurement points are not critical as long as the calculation is consistent. The parameters tLZ(DQS), tLZ(DQ), tHZ(DQS), and tHZ(DQ) are defined as single ended.

2.8.1. tLZ(DQS) and tHZ(DQS) Calculation for ATE (Automatic Test Equipment)



Note

1. Conditions for Calibration: Pull Down Driver Ron = 40ohm, VOH = VDDQ/3
2. Termination condition for DQS_t and DQS_c = 50ohm to VSSQ.
3. The VOH level depends on MR22 OP[2:0] and MR3 OP[0] settings as well as device tolerances. Use the actual VOH value for tHZ and tLZ measurements.

Figure 13 - tLZ(DQS) method for calculating transitions and end point

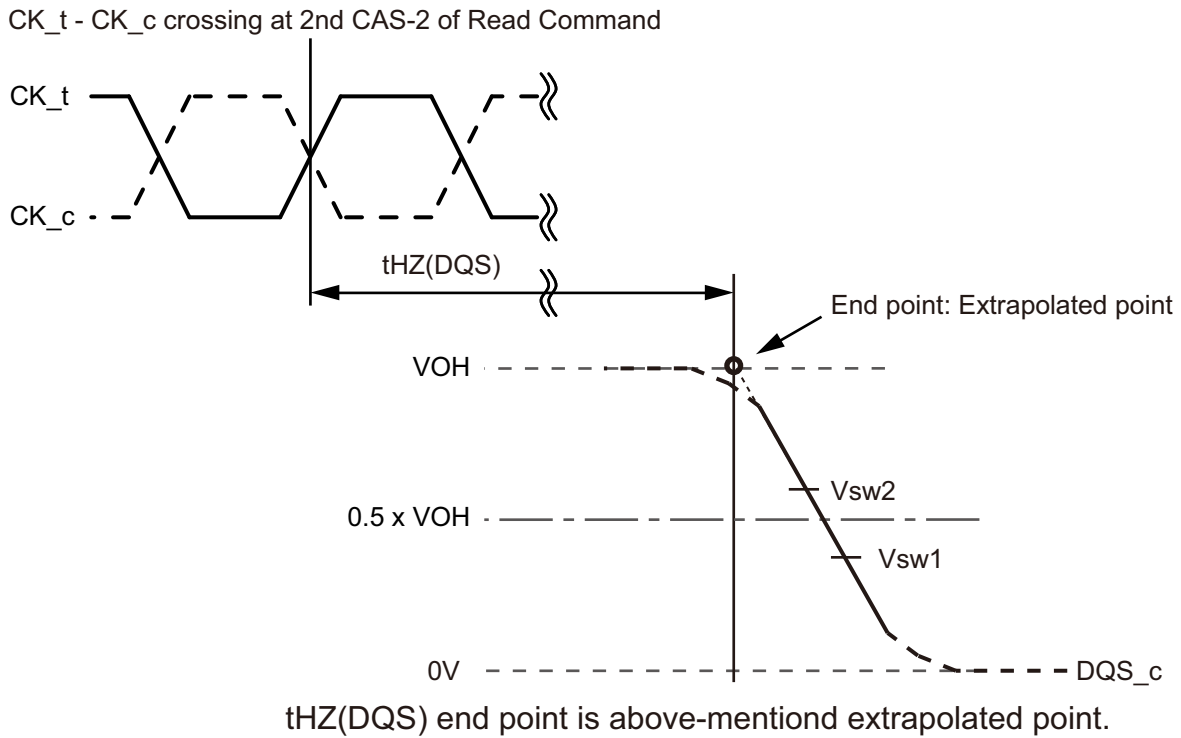

Note

1. Conditions for Calibration: Pull Down Driver Ron = 40ohm, VOH = VDDQ/3
2. Termination condition for DQS_t and DQS_c = 50ohm to VSSQ.
3. The VOH level depends on MR22 OP[2:0] and MR3 OP[0] settings as well as device tolerances. Use the actual VOH value for tHZ and tLZ measurements.

Figure 14 - tHZ(DQS) method for calculating transitions and end point

Table 17 - Reference voltage for tLZ(DQS), tHZ(DQS) Timing Measurements

Measured Parameter	Symbol	Vsw1 [V]	Vsw2 [V]
DQS _c low-impedance time from CK _t , CK _c	tLZ(DQS)	0.4 x VOH	0.6 x VOH
DQS _c high impedance time from CK _t , CK _c	tHZ(DQS)	0.4 x VOH	0.6 x VOH

2.8.2. tLZ(DQ) and tHZ(DQ) Calculation for ATE (Automatic Test Equipment)

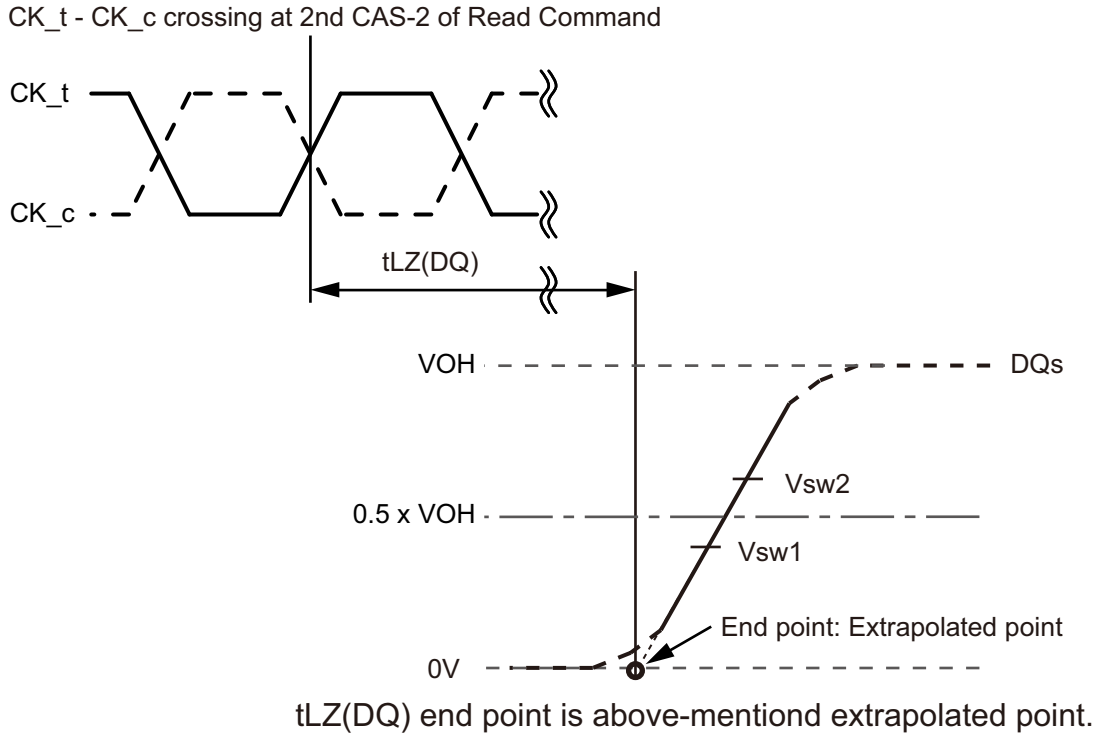

Note

1. Conditions for Calibration: Pull Down Driver Ron = 40ohm, VOH = VDDQ/3
2. Termination condition for DQ and DMI = 50ohm to VSSQ.
3. The VOH level depends on MR22 OP[2:0] and MR3 OP[0] settings as well as device tolerances. Use the actual VOH value for tHZ and tLZ measurements.

Figure 15 - tLZ(DQ) method for calculating transitions and end point

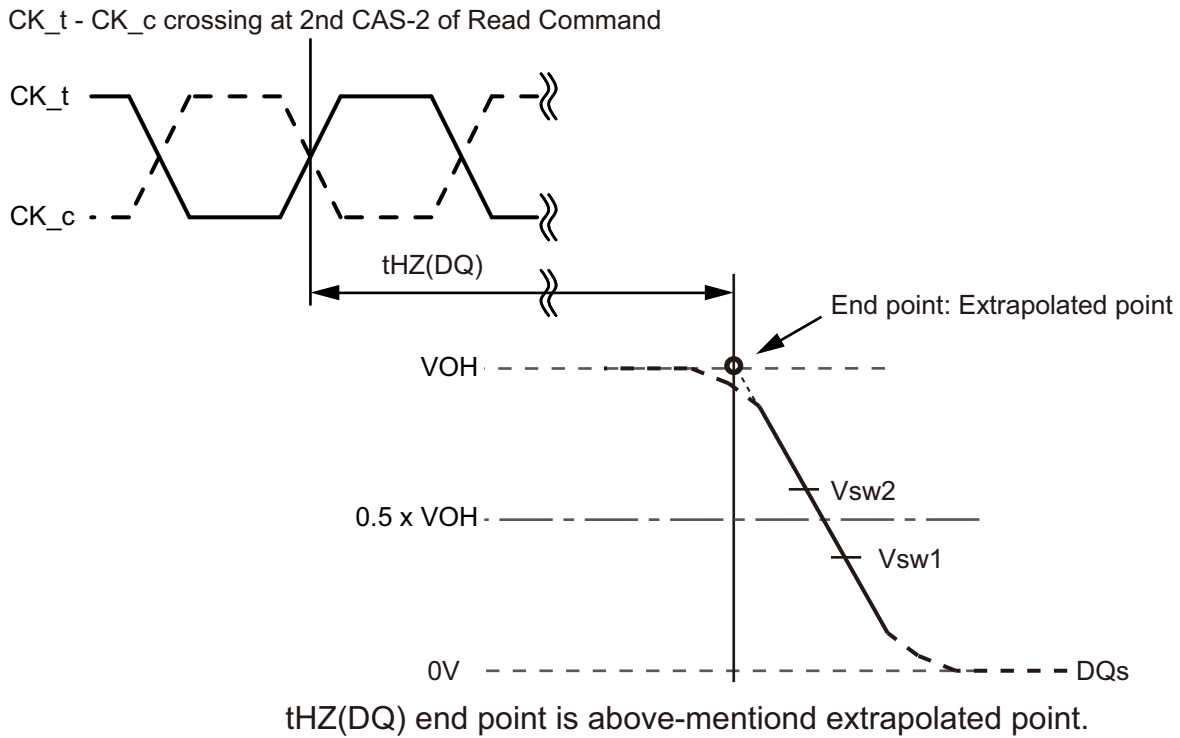

Note

1. Conditions for Calibration: Pull Down Driver Ron = 40ohm, VOH = VDDQ/3
2. Termination condition for DQ and DMI = 50ohm to VSSQ.
3. The VOH level depends on MR22 OP[2:0] and MR3 OP[0] settings as well as device tolerances. Use the actual VOH value for tHZ and tLZ measurements.

Figure 16 - tHZ(DQ) method for calculating transitions and end point

Table 18 - Reference voltage for tLZ(DQS), tHZ(DQS) Timing Measurements

Measured Parameter	Symbol	Vsw1 [V]	Vsw2 [V]
DQ low-impedance time from CK _t , CK _c	tLZ(DQ)	0.4 x VOH	0.6 x VOH
DQ high impedance time from CK _t , CK _c	tHZ(DQ)	0.4 x VOH	0.6 x VOH

2.8.3. tRPRE Calculation for ATE(Automatic Test Equipment)

The method for calculating differential pulse widths for tRPRE is shown in Figure below.

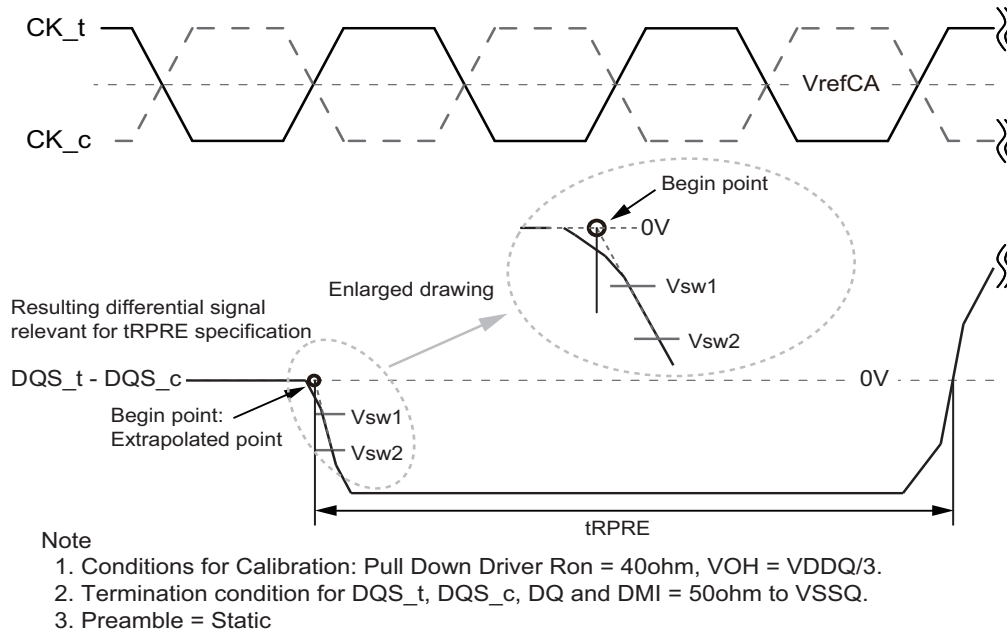

Figure 17 - 18 Method for calculating tRPRE transitions and endpoints

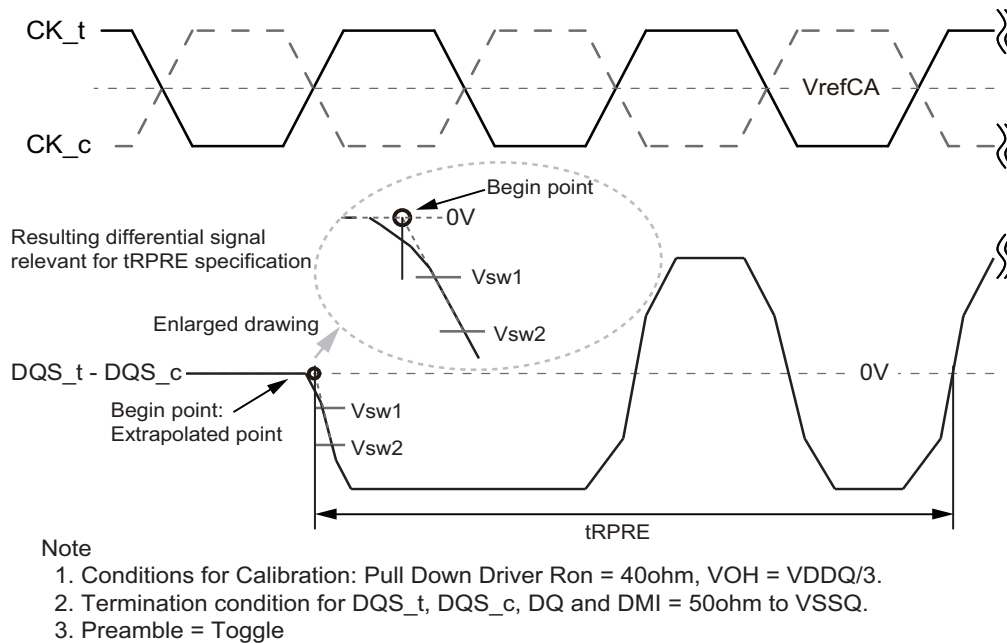

Figure 18 - Method for calculating tRPRE transitions and endpoints

Table 19 - Reference Voltage for tRPRE Timing Measurements

Measured Parameter	Symbol	Vsw1[V]	Vsw2[V]	Note
DQS_t, DQS_c differential Read Preamble	tRPRE	-(0.3 x VOH)	-(0.7 x VOH)	

2.8.4. tRPST Calculation for ATE(Automatic Test Equipment)

The method for calculating differential pulse widths for tRPST is shown in Figure 20.

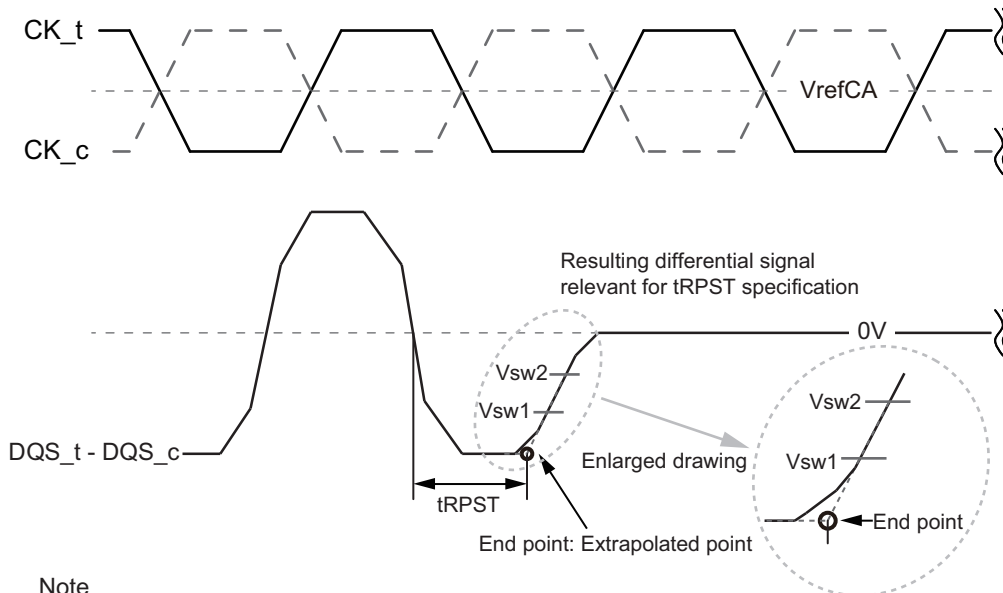

Note

1. Conditions for Calibration: Pull Down Driver Ron = 40ohm, VOH = VDDQ/3.
2. Termination condition for DQS_t, DQS_c, DQ and DMI = 50ohm to VSSQ.
3. Read Postamble: 0.5tCK
4. The method for calculating differential pulse widths for 1.5 tCK Postamble is same as 0.5 tCK Postamble.

Figure 19 - 20 Method for calculating tRPST transitions and endpoints

Table 20 - Reference Voltage for tRPST Timing Measurements

Measured Parameter	Symbol	Vsw1[V]	Vsw2[V]	Note
DQS_t, DQS_c differential Read Postamble	tRPST	-(0.7 x VOH)	-(0.3 x VOH)	

Table 21 - Read AC timing

Parameter	Symbol	min max	533	1066	1600	2133	2667	3200	3733	4266	Unit	Note
Read preamble	tRPRE	min	1.8								tCK (avg)	
Read postamble	tRPST	min	0.4								tCK (avg)	
Extended Read postamble	tRPSTE	min	1.4								tCK (avg)	
DQ low-impedance time from CK_t, CK_c	tLZ(DQ)	Min	$(RL \times tCK) + tDQSCK(\text{Min}) - 200\text{ps}$								ps	
DQ high impedance time from CK_t, CK_c	tHZ(DQ)	Max	$(RL \times tCK) + tDQSCK(\text{Max}) + tDQSQ(\text{Max}) + (BL/2 \times tCK) - 100\text{ps}$								ps	
DQS_c low-impedance time from CK_t, CK_c	tLZ(DQS)	Min	$(RL \times tCK) + tDQSCK(\text{Min}) - (tRPRE(\text{Max}) \times tCK) - 200\text{ps}$								ps	
DQS_c high impedance time from CK_t, CK_c	tHZ(DQS)	Max	$(RL \times tCK) + tDQSCK(\text{Max}) + (BL/2 \times tCK) + (RPST(\text{Max}) \times tCK) - 100\text{ps}$								ps	
DQS-DQ skew	tDQSQ	max	0.18								UI	

2.9. tDQSK Timing Table

Table 22 - tDQSK AC timing

Parameter	Symbol	min max	533	1066	1600	2133	2667	3200	3733	4266	Unit	Note
DQS Output Access Time from CK_t/CK_c	tDQSK	min	1.5								ns	1
		max	3.5									
DQS Output Access Time from CK_t/CK_c - Temperature Variation	tDQSK_temp	max	4								ps/°C	2
DQS Output Access Time from CK_t/CK_c - Voltage Variation	tDQSK_volt	max	7								ps/mV	3

Notes

1. Includes DRAM process, voltage and temperature variation. It includes the AC noise impact for frequencies > 20 MHz and max voltage of 45 mV pk-pk from DC-20 MHz at a fixed temperature on the package. The voltage supply noise must comply to the component Min-Max DC Operating conditions.

2. tDQSK_temp max delay variation as a function of Temperature.

3. tDQSK_volt max delay variation as a function of DC voltage variation for V_{DDQ} and V_{DD2}. tDQSK_volt should be used to calculate timing variation due to V_{DDQ} and V_{DD2} noise < 20 MHz. Host controller do not need to account for any variation due to V_{DDQ} and V_{DD2} noise > 20 MHz.

The voltage supply noise must comply to the component Min-Max DC Operating conditions.

The voltage variation is defined as the $\text{Max}[\text{abs}\{tDQSK_{\text{min}}@V1 - tDQSK_{\text{max}}@V2\}, \text{abs}\{tDQSK_{\text{max}}@V1 - tDQSK_{\text{min}}@V2\}] / \text{abs}\{V1 - V2\}$.

For tester measurement V_{DDQ} = V_{DD2} is assumed.

2.9.1. CK to DQS Rank to Rank Variation

Table 23 - tDQSK_rank2rank AC timing

Parameter	Symbol	min max	533	1066	1600	2133	2667	3200	3733	4266	Unit	Note
CK to DQS rank to Rank Variation	tDQSK_rank2rank	max	1.0								ns	1,2

Notes

1. The same voltage and temperature are applied to tDQSK_rank2rank.

2. tDQSK_rank2rank parameter is applied to multi-ranks per byte lane within a package consisting of the same design dies.

2.10. Write Preamble and Postamble

The DQS strobe for the LPDDR4-SDRAM requires a pre-amble prior to the first latching edge (the rising edge of DQS_t with DATA "valid"), and it requires a post-amble after the last latching edge. The pre-amble and post-amble lengths are set via mode register writes (MRW).

For WRITE operations, a 2*tCK pre-amble is required at all operating frequencies.

LPDDR4 will have a DQS Write post-amble of 0.5*tCK or extended to 1.5*tCK. Standard DQS post-amble will be 0.5*tCK driven by the memory controller for Writes. A mode register setting instructs the DRAM to drive an additional (extended) one cycle DQS Write post-amble. The drawings below show examples of DQS Write post-amble for both standard (tWPST) and extended (tWPSTE) post-amble operation.

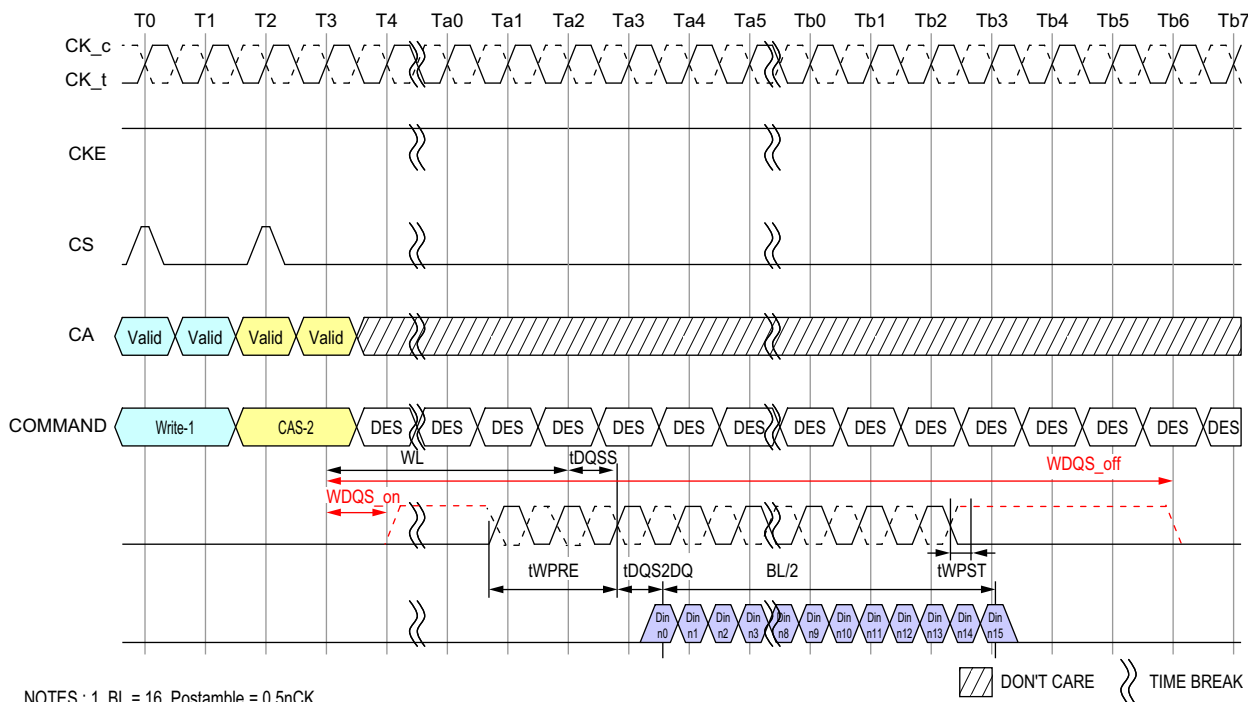

- NOTES : 1. BL = 16, Postamble = 0.5nCK
 2. DQS and DQ terminated VSSQ
 3. DQS_t/DQS_c is "don't care" prior to the start of tWPST.
 No transition of DQS is implied, as DQS_t/DQS_c can be HIGH, LOW, or HI-Z prior to tWPST.

Figure 20 - DQS Write Preamble and Postamble; 0.5nCK Postamble

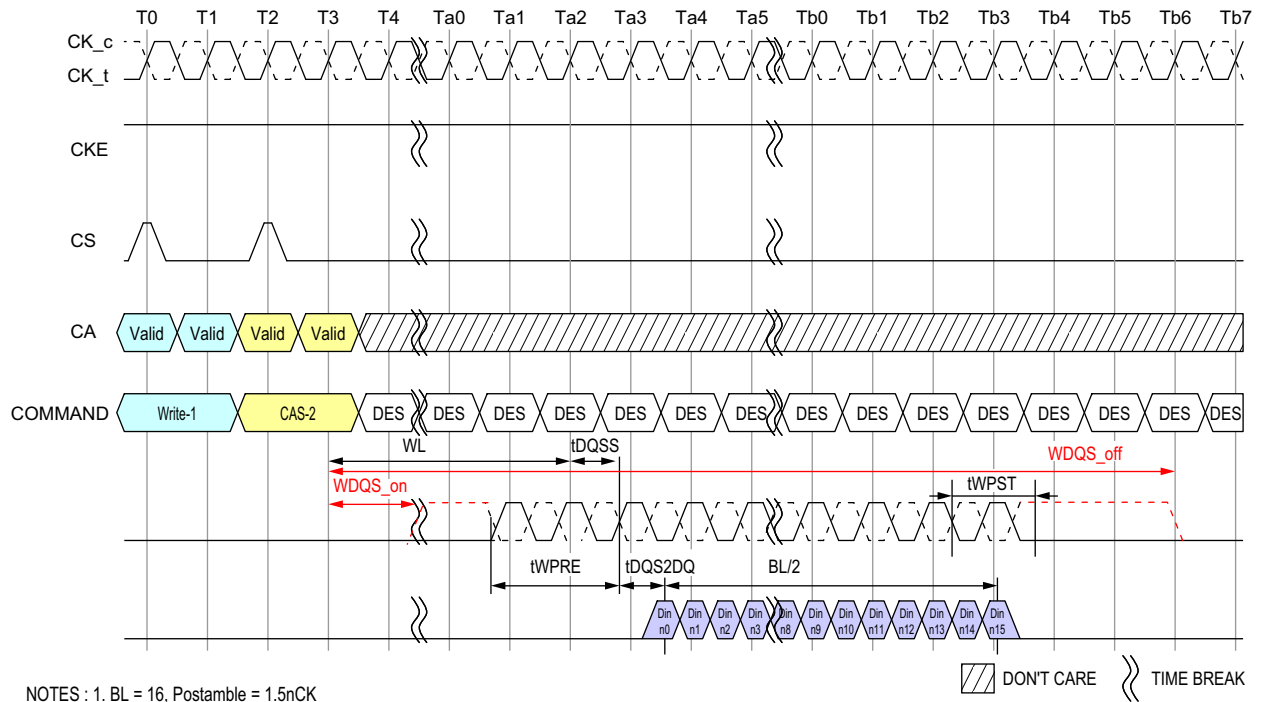

- NOTES : 1. BL = 16, Postamble = 1.5nCK
 2. DQS and DQ terminated VSSQ
 3. DQS_t/DQS_c is "don't care" prior to the start of tWPRE.
 No transition of DQS is implied, as DQS_t/DQS_c can be HIGH, LOW, or HI-Z prior to tWPRE.

Figure 21 - DQS Write Preamble and Postamble: 1.5nCK Postamble

2.11. Burst Write Operation

A burst WRITE command is initiated with CS, and CA[5:0] asserted to the proper state at the rising edge of CK, as defined by the Command Truth Table. Column addresses C[3:2] should be driven LOW for Burst WRITE commands, and column addresses C[1:0] are not transmitted on the CA bus (and are assumed to be zero), so that the starting column burst address is always aligned with a 32B boundary. The write latency (WL) is defined from the last rising edge of the clock that completes a write command (Ex: the second rising edge of the CAS-2 command) to the rising edge of the clock from which tDQSS is measured. The first valid "latching" edge of DQS must be driven $WL * tCK + tDQSS$ after the rising edge of Clock that completes a write command.

The LPDDR4-SDRAM uses an un-matched DQS-DQ path for lower power, so the DQS-strobe must arrive at the SDRAM ball prior to the DQ signal by the amount of tDQS2DQ. The DQS-strobe output is driven tWPRE before the first valid rising strobe edge. The tWPRE pre-amble is required to be $2 \times tCK$. The DQS strobe must be trained to arrive at the DQ pad center-aligned with the DQ-data. The DQ-data must be held for tDIVW (data input valid window) and the DQS must be periodically trained to stay centered in the tDIVW window to compensate for timing changes due to temperature and voltage variation. Burst data is captured by the SDRAM on successive edges of DQS until the 16 or 32 bit data burst is complete. The DQS-strobe must remain active (toggling) for tWPST (WRITE post-amble) after the completion of the burst WRITE. After a burst WRITE operation, tWR must be satisfied before a PRECHARGE command to the same bank can be issued. Pin input timings are measured relative to the cross point of DQS_t and DQS_c.

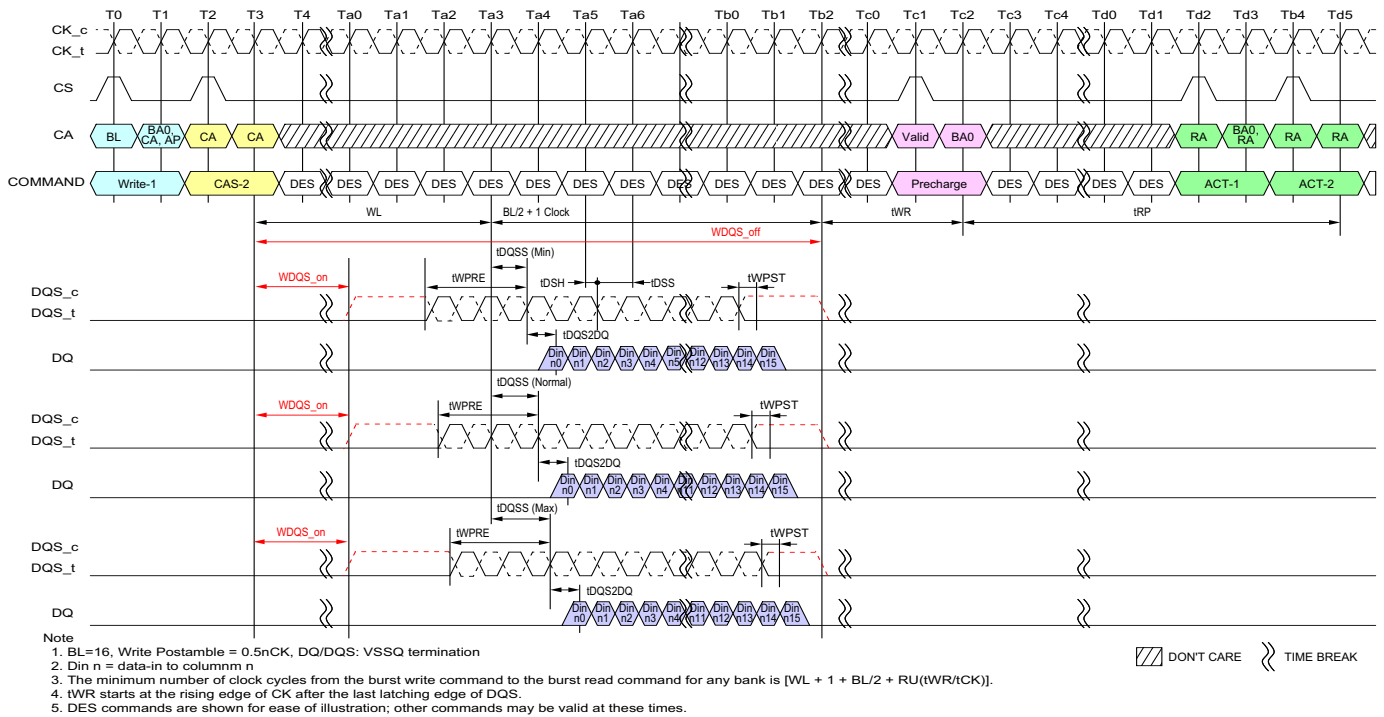
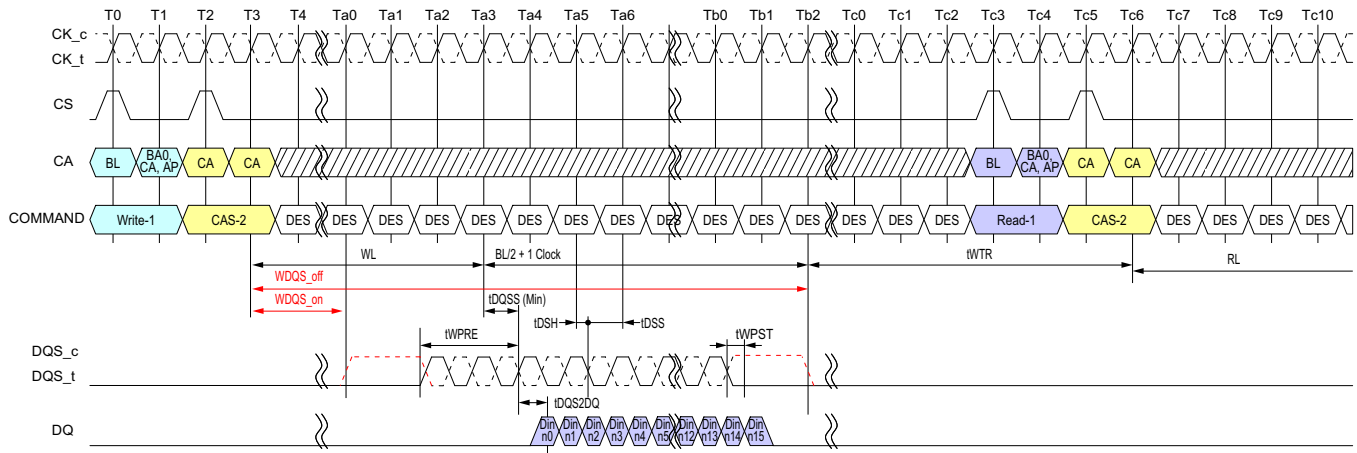

Figure 22 - Burst Write Operation



Note

1. BL=16, Write Postamble = 0.5nCK, DQ/DQS: VSSQ termination
2. Din n = data-in to column n
3. The minimum number of clock cycles from the burst write command to the burst read command for any bank is [WL + 1 + BL/2 + RU(IWTR/ICK)].
4. tWTR starts at the rising edge of CK after the last latching edge of DQS.
5. DES commands are shown for ease of illustration; other commands may be valid at these times.

 DONT CARE
  TIME BREAK

Figure 23 - Burst Write Followed by Burst Read

2.12. Write Timing

The write timing is shown in the following figure.

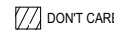
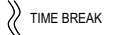
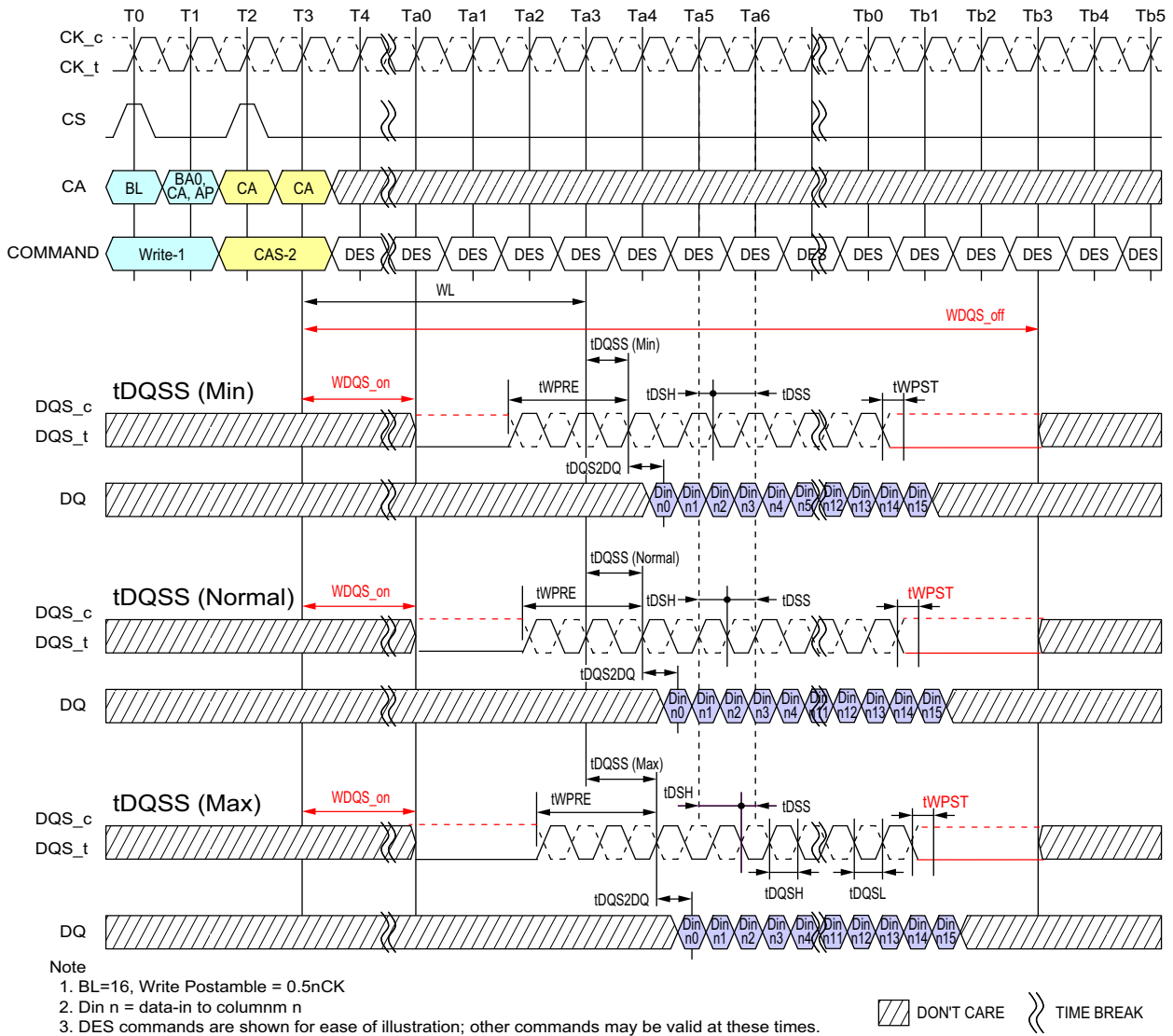
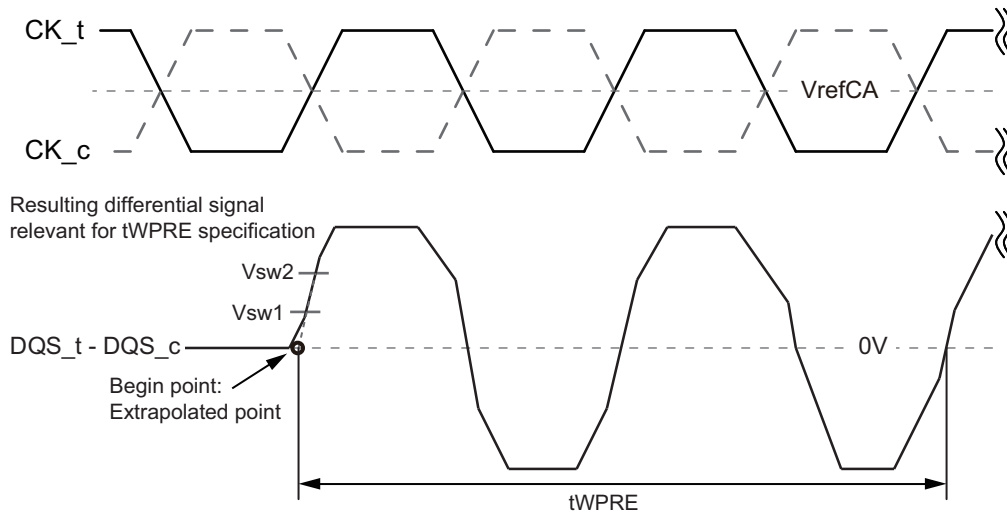

Figure 24 - Write Timing

2.12.1. tWPRE Calculation for ATE (Automated Test Equipment)

The method for calculating differential pulse widths for tWPRE is shown in the following figure.



Note

1. Termination condition for DQS_t, DQS_c, DQ and DMI = 50ohm to VSSQ.

Figure 25 - Method for calculating tWPRE transitions and endpoints

Table 24 - Reference Voltage for tWPRE Timing Measurements

Measured Parameter	Symbol	Vsw1 [V]	Vsw2 [V]
DQS _t , DQS _c differential Write Preamble	tWPRE	VIHL _{AC} x 0.3	VIHL _{AC} x 0.7

2.12.2. tWPST Calculation for ATE (Automatic Test Equipment)

The method for calculating differential pulse widths for tWPST is shown in the following figure.

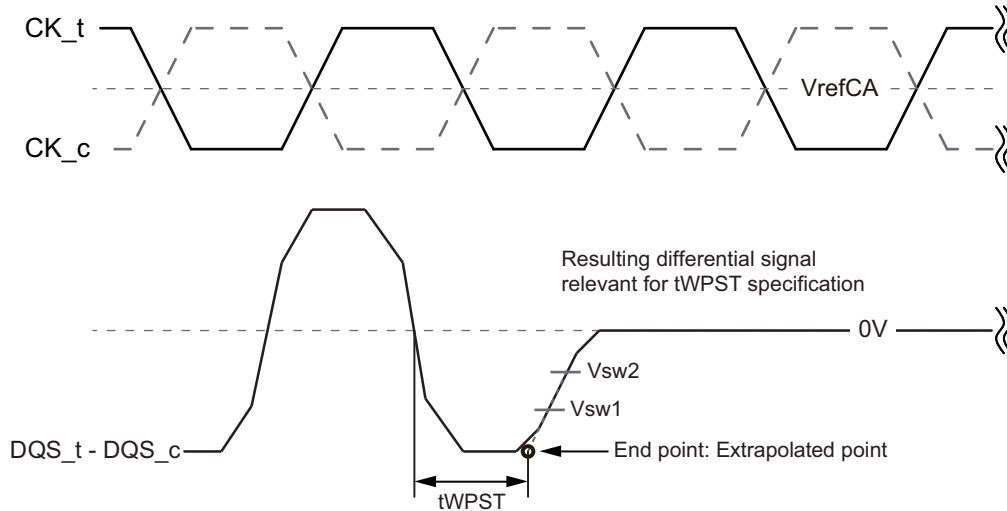

Note

1. Termination condition for DQS_t, DQS_c, DQ and DMI = 50ohm to VSSQ.
2. Write Postamble: 0.5tCK
3. The method for calculating differential pulse widths for 1.5 tCK Postamble is same as 0.5 tCK Postamble.

Figure 26 - Method for calculating tWPST transitions and endpoints

Table 25 - Reference Voltage for tWPST Timing Measurements

Measured Parameter	Symbol	Vsw1 [V]	Vsw2 [V]
DQS _t , DQS _c differential Write Preamble	tWPST	- (VIHL _{AC} x 0.7)	- (VIHL _{AC} x 0.3)

Table 26 - Write AC timing

Parameter	Symbol	min max	533	1066	1600	2133	2667	3200	3733	4266	Unit	Note
Write command to 1st DQS latching transition	tDQSS	Min	0.75								tCK (avg)	
		Max	1.25									
DQS input high-level width	tDQSH	Min	0.4								tCK (avg)	
DQS input low-level width	tDQSL	Min	0.4								tCK (avg)	
DQS falling edge to CK setup time	tDSS	Min	0.2								tCK (avg)	
DQS falling edge hold time from CK	tDSH	Min	0.2								tCK (avg)	
Write preamble	tWPRE	Min	1.8								tCK (avg)	
0.5 tCK Write postamble	tWPST	Min	0.4								tCK (avg)	1
1.5 tCK Write postamble	tWPST	Min	1.4								tCK (avg)	1

Notes

1. The length of Write Postamble depends on MR3 OP1 setting.

2.13. Read and Write Latencies
Table 27 - Read and Write Latencies (Frequency Ranges for RL, WL, and nWR Settings)

Read Latency		Write Latency		nWR	nRTP	Freq. limit (Greater than)	Freq. limit (Same or less than)	Notes
No DBI	w/ DBI	Set "A"	Set "B"					
6	6	4	4	6	8	10	266	1,2,3,4, 5,6
10	12	6	8	10	8	266	533	
14	16	8	12	16	8	533	800	
20	22	10	18	20	8	800	1066	
24	28	12	22	24	10	1066	1333	
28	32	14	26	30	12	1333	1600	
32	36	16	30	34	14	1600	1866	
36	40	18	34	40	16	1866	2133	
nCK	nCK	nCK	nCK	nCK	nCK	MHz	MHz	

Notes

1. The LPDDR4-SDRAM device should not be operated at a frequency above the Upper Frequency Limit, or below the Lower Frequency Limit, shown for each RL, WL, nRTP, or nWR value.
2. DBI for Read operations is enabled in MR3-OP[6]. When MR3-OP[6]=0, then the "No DBI" column should be used for Read Latency. When MR3-OP[6]=1, then the "w/DBI" column should be used for Read Latency.
3. Write Latency Set "A" and Set "B" is determined by MR2-OP[6]. When MR2-OP[6]=0, then Write Latency Set "A" should be used. When MR2-OP[6]=1, then Write Latency Set "B" should be used.
4. The programmed value of nWR is the number of clock cycles the LPDDR4-SDRAM device uses to determine the starting point of an internal Pre-charge operation after a Write burst with AP (auto-pre-charge) enabled. It is determined by RU(tWR/tCK).
5. The programmed value of nRTP is the number of clock cycles the LPDDR4-SDRAM device uses to determine the starting point of an internal Pre-charge operation after a Read burst with AP (auto-pre-charge) enabled. It is determined by RU(tRTP/tCK).
6. nRTP shown in this table is valid for BL16 only. For BL32, the SDRAM will add 8 clocks to the nRTP value before starting a pre-charge.

Table 28 - Read and Write Latencies for Byte (x8) mode

Read Latency		Write Latency		nWR	nRTP	Freq. limit (Greater than)	Freq. limit (Same or less than)	Notes
No DBI	w/ DBI	Set "A"	Set "B"					
6	6	4	4	6	8	10	266	1,2,3,4, 5,6
10	12	6	8	12	8	266	533	
16	18	8	12	16	8	533	800	
22	24	10	18	22	8	800	1066	
26	30	12	22	28	10	1066	1333	
32	36	14	26	32	12	1333	1600	
36	40	16	30	38	14	1600	1866	
40	44	18	34	44	16	1866	2133	
nCK	nCK	nCK	nCK	nCK	nCK	MHz	MHz	

Notes

1. The LPDDR4-SDRAM device should not be operated at a frequency above the Upper Frequency Limit, or below the Lower Frequency Limit, shown for each RL, WL, nRTP, or nWR value.
2. DBI for Read operations is enabled in MR3-OP[6]. When MR3-OP[6]=0, then the "No DBI" column should be used for Read Latency. When MR3-OP[6]=1, then the "w/DBI" column should be used for Read Latency.
3. Write Latency Set "A" and Set "B" is determined by MR2-OP[6]. When MR2-OP[6]=0, then Write Latency Set "A" should be used. When MR2-OP[6]=1, then Write Latency Set "B" should be used.
4. The programmed value of nWR is the number of clock cycles the LPDDR4-SDRAM device uses to determine the starting point of an internal Pre-charge operation after a Write burst with AP (auto-pre-charge) enabled. It is determined by $RU(tWR/tCK)$.
5. The programmed value of nRTP is the number of clock cycles the LPDDR4-SDRAM device uses to determine the starting point of an internal Pre-charge operation after a Read burst with AP (auto-pre-charge) enabled. It is determined by $RU(tRTP/tCK)$.
6. nRTP shown in this table is valid for BL16 only. For BL32, the SDRAM will add 8 clocks to the nRTP value before starting a pre-charge.

2.14. Write and Masked Write operation DQS controls (WDQS Control)

LPDDR4-SDRAMs support write and masked write operations with the following DQS controls. Before and after Write and Masked Write operations are issued, DQS_t/DQS_c is required to have a sufficient voltage gap to make sure the write buffers operating normally without any risk of metastability.

The LPDDR4-SDRAM is supported by either of two WDQS control modes

Mode 1: Read Based Control

Mode 2 : WDQS_{on} / WDQS_{off} definition based control

Regardless of ODT enable/disable, WDQS related timing described in 4.13 does not allow any change of existing command timing constraints for all read/write operations. In case of any conflict or ambiguity on the command timing constraints caused by what is specified in 4.13, the specifications defined in 4.38, Table 74 (or 4.13.1, and 4.13.2) should have higher priority than WDQS control requirements.

Some legacy products may not provide WDQS control described below. However, in order to prevent the write preamble related failure, it is strongly recommended to support either of two WDQS controls to LPDDR4-SDRAMs. In the case of legacy SoC which may not provide WDQS control modes, it is required to consult DRAM vendors to guarantee the write / masked write operation appropriately.

2.14.1. WDQS Control Mode 1 - Read Based Control

The LPDDR4-SDRAM needs to be guaranteed the differential WDQS, but the differential WDQS can be controlled as described below. WDQS control requirements here can be ignored while differential read DQS is operated or while DQS hands over from Read to Write and vice versa.

1. At the time a write / masked write command is issued, SoC makes the transition from driving DQS_c high to driving differential DQS_t/DQS_c, followed by normal differential burst on DQS pins.
2. At the end of postamble of write /masked write burst, SoC resumes driving DQS_c high through the subsequent states except for DQS toggling and DQS turn around time of WT-RD and RD-WT as long as CKE is high.
3. When CKE is low, the state of DQS_t and DQS_c is allowed to be "Don't Care".

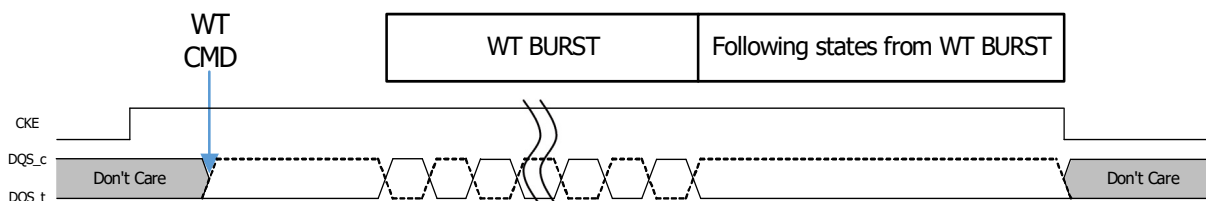

2.14.2. WDQS Control Mode 2 - WDQS_on/off

After write / masked write command is issued, DQS_t and DQS_c required to be differential from WDQS_on, and DQS_t and DQS_c can be “Don’t Care” status from WDQS_off of write / masked write command. When ODT is enabled, WDQS_on and WDQS_off timing is located in the middle of the operations. When host disables ODT, WDQS_on and WDQS_off constraints conflict with tRTW. The timing does not conflict when ODT is enabled because WDQS_on and WDQS_off timing is covered in ODTLon and ODTLoff. However, regardless of ODT on/off, WDQS_on/off timing below does not change any command timing constraints for all read and write operations. In order to prevent the conflict, WDQS_on/off requirement can be ignored when WDQS_on/off timing is overlapped with read operation period including Read burst period and tRPST or overlapped with turn-around time (RD-WT or WT-RD). In addition, the period during DQS toggling caused by Read and Write can be counted as WDQS_on/off.

Parameters

- WDQS_on: the max delay from write / masked write command to differential DQS_t and DQS_c.
 - WDQS_off : the min delay for DQS_t and DQS_c differential input after the last write / masked write command.
 - WDQS_Exception : the period where WDQS_on and WDQS_off timing is overlapped with read operation or with DQS turn around (RD-WT, WT-RD).
- WDQS_Exception @ ODT disable = max (WL-WDQS_on+tDQSTA- tWPRE - n*tCK, 0 tCK)
 where RD to WT command gap = tRTW(min)@ODT disable + n*tCK
- WDQS_Exception @ ODT enable = tDQSTA

Table 29 - WDQS_on / WDQS_off Definition

RL		WL		nWR	nRTP	WDQS_on (max)		WDQS_off (min)		Lower Clock Freq limit (>)	Upper Clock Freq limit (<=)
Set A	Set B	Set A	Set B			Set A	Set B	Set A	Set B		
6	6	4	4	6	8	0	0	15	15	10	266
10	12	6	8	10	8	0	0	18	20	266	533
14	16	8	12	16	8	0	6	21	25	533	800
20	22	10	18	20	8	4	12	24	32	800	1066
24	28	12	22	24	10	4	14	27	37	1066	1333
28	32	14	26	30	12	6	18	30	42	1333	1600
32	36	16	30	34	14	6	20	33	47	1600	1866
36	40	18	34	40	16	8	24	36	52	1866	2133
nCK	nCK	nCK	nCK	nCK	nCK	nCK	nCK	nCK	nCK	Mhz	Mhz

Notes

1. WDQS_on/off requirement can be ignored wWDQS_on/off timing is overlapped with read operation period including Read burst period and tRPST or overlapped with turn-around time (RD-WT or WT-RD).
2. The period DQS toggling caused by Read and Write can be counted as WDQS_on/off.

Table 30 - WDQS_on / WDQS_off Allowable Variation Range

	min	max	Unit
WDQS_On	-0.25	+0.25	tCK (avg)
WDQS_Off	-0.25	+0.25	tCK (avg)

Table 31 - DQS turn around parameter

Parameter	Description	Value	Unit	Note
tDQSTA	Turn-around time RDQS to WDQS for WDQS control case	TBD	-	1

Notes

1. tDQSTA is only applied to WDQS_exception case when WDQS Control. Except for WDQS Control, tDQSTA can be ignored.

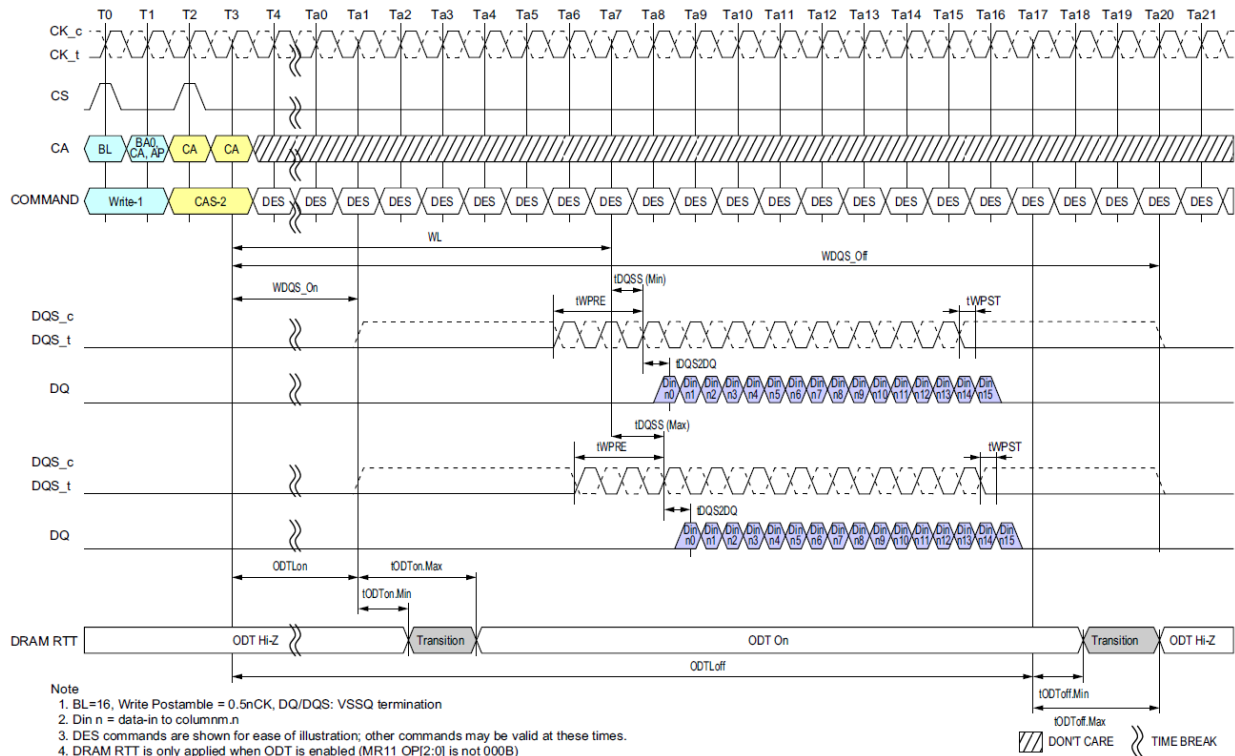

Figure 27 - Burst Write Operation

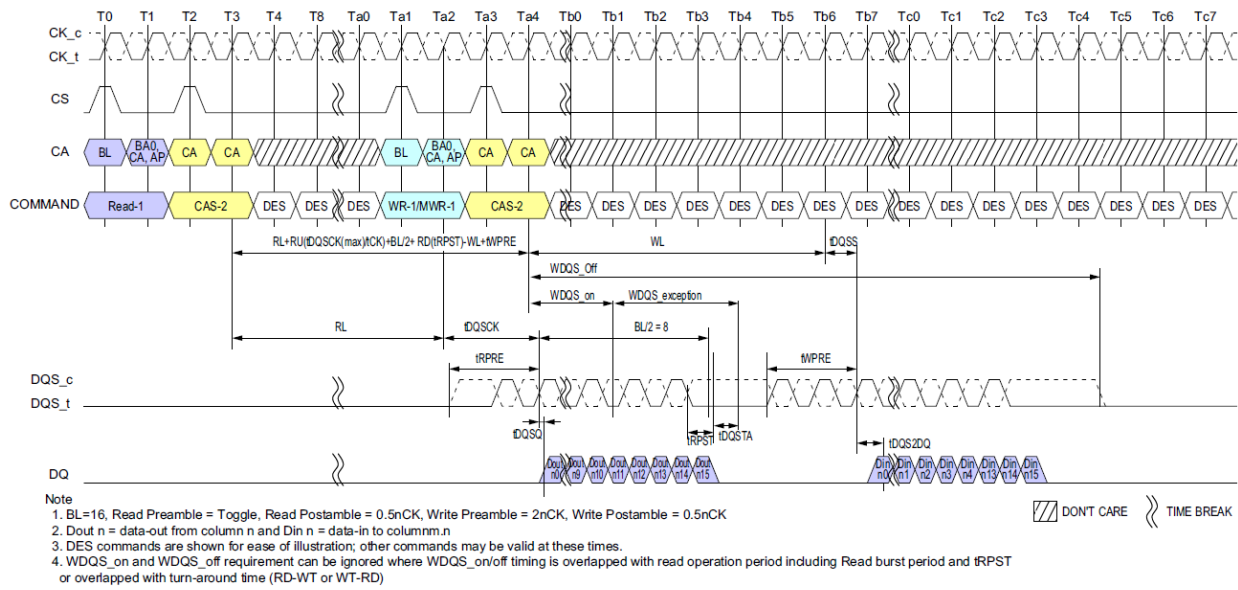

Figure 28 - Burst Read followed by Burst Write or Burst Mask Write (ODT Disable)

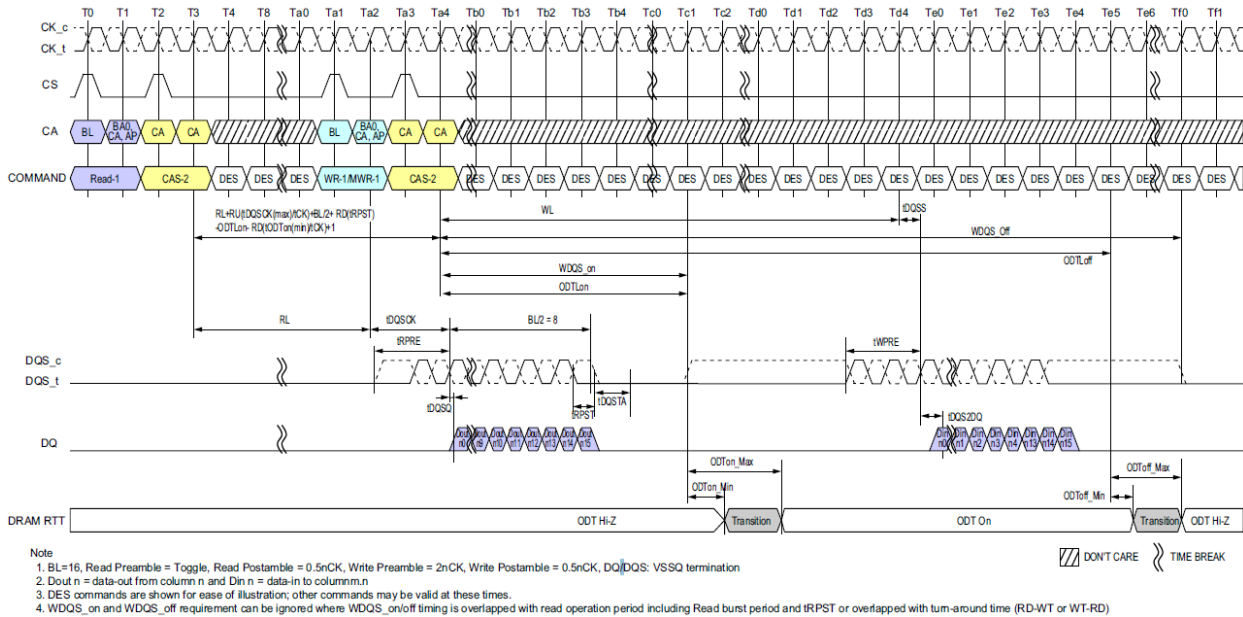

Figure 29 - Burst Read followed by Burst Write or Burst Mask Write (ODT Enable)

2.15. Postamble and Preamble merging behavior

The DQS strobe for the device requires a preamble prior to the first latching edge (the rising edge of DQS_t with data valid), and it requires a postamble after the last latching edge. The preamble and postamble options are set via Mode Register Write commands.

In Read to Read or Write to Write operations with $t_{CCD} = BL/2$, postamble for 1st command and preamble for 2nd command will disappear to create consecutive DQS latching edge for seamless burst operations.

But in the case of Read to Read or Write to Write operations with command interval of $t_{CCD} + 1, t_{CCD} + 2$, etc., they will not completely disappear because it's not seamless burst operations.

Timing diagrams in this material describe Postamble and Preamble merging behavior in Read to Read or Write to Write operations with $t_{CCD} + n$.

2.15.1. Read to Read Operation

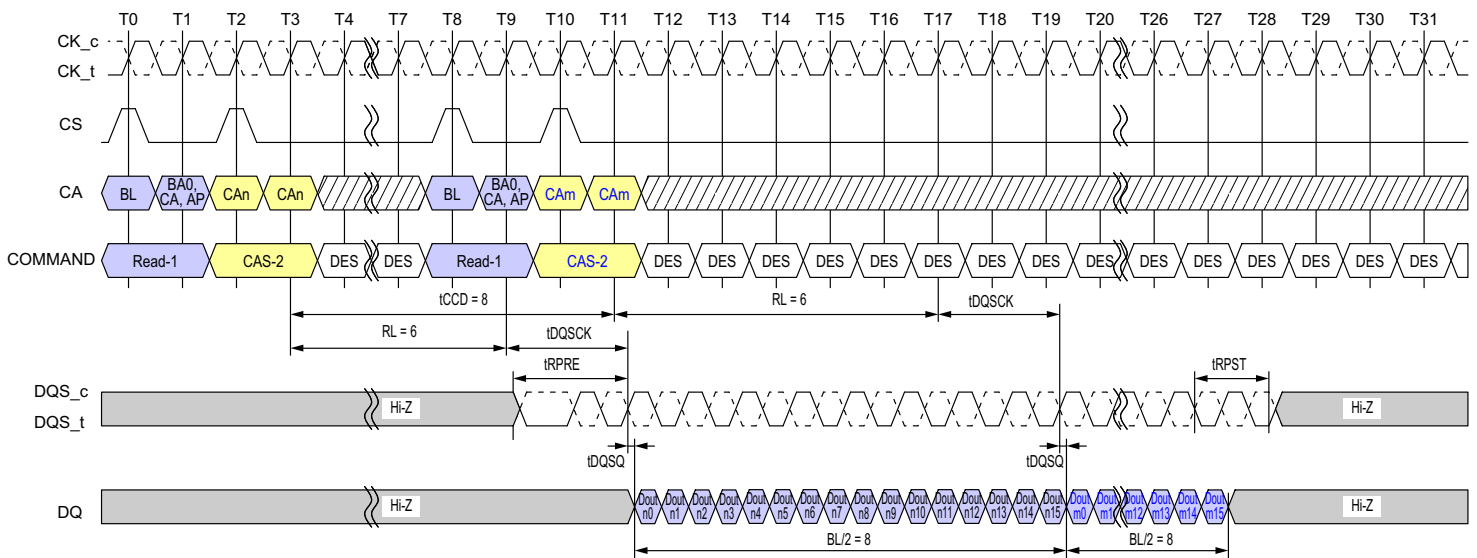

Note

1. BL = 16 for column n and column m, RL = 6, Preamble = Toggle, Postamble = 1.5nCK
2. Dout n/m = data-out from column n and column m.
3. DES commands are shown for ease of illustration; other commands may be valid at these times.

▨ DONT CARE >>> TIME BREAK

Figure 30 - Seamless Reads Operation: $t_{CCD} = \text{Min}$, Preamble = Toggle, 1.5nCK Postamble

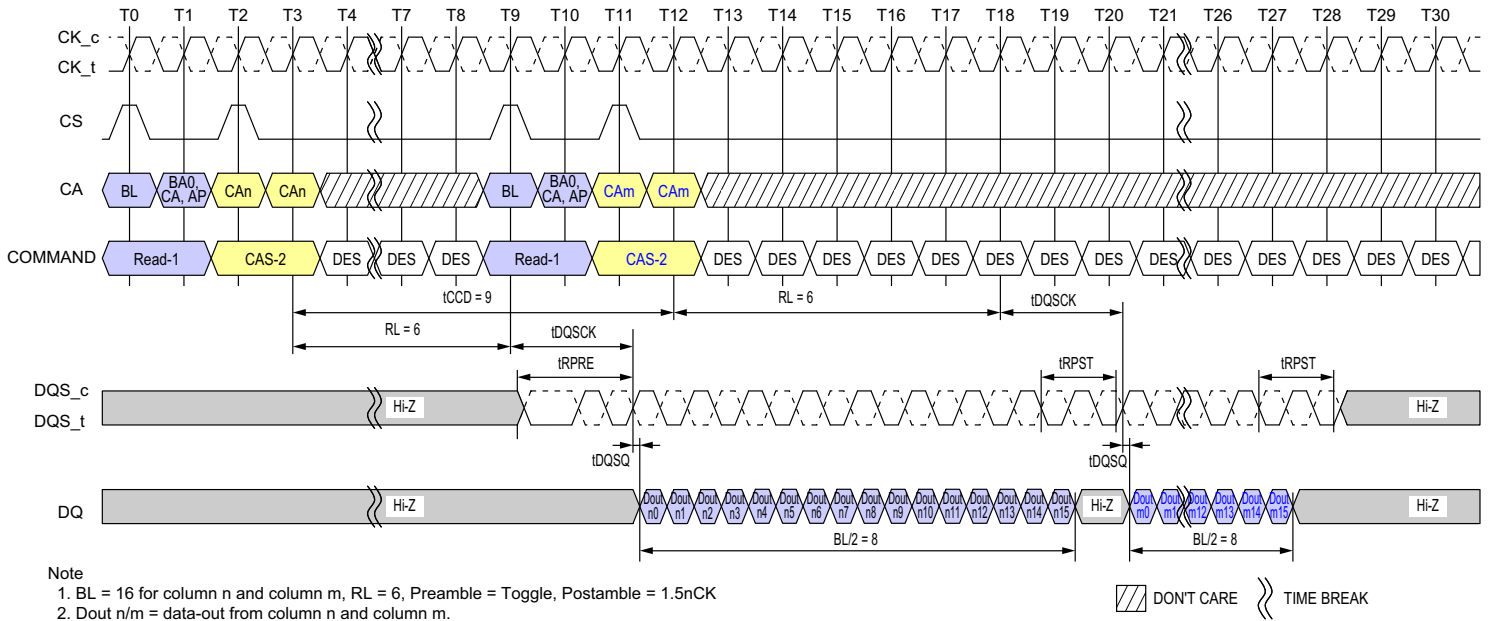

Figure 31 - Consecutive Reads Operation: tCCD = Min+1, Preamble=Toggle, 1.5nCK Postamble

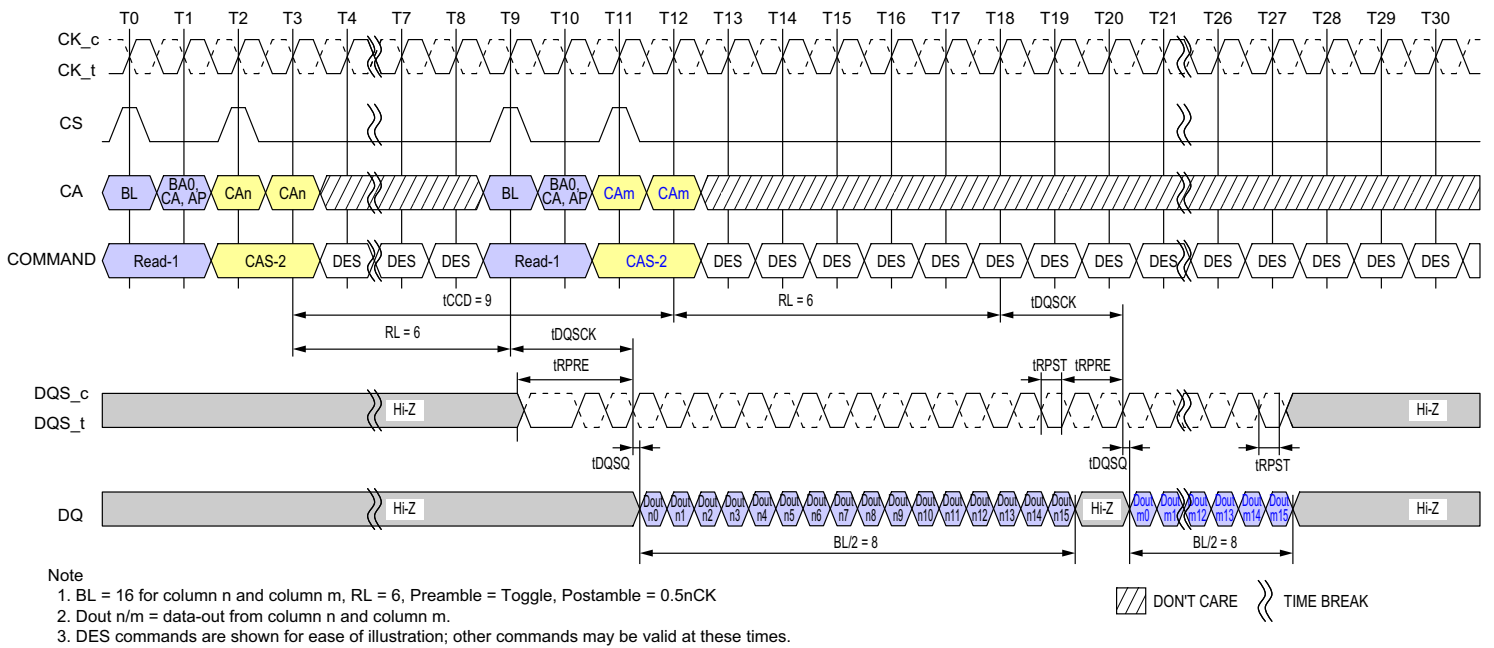

Figure 32 - Consecutive Reads Operation: tCCD=Min+1, Preamble=Toggle, 0.5nCK Postamble

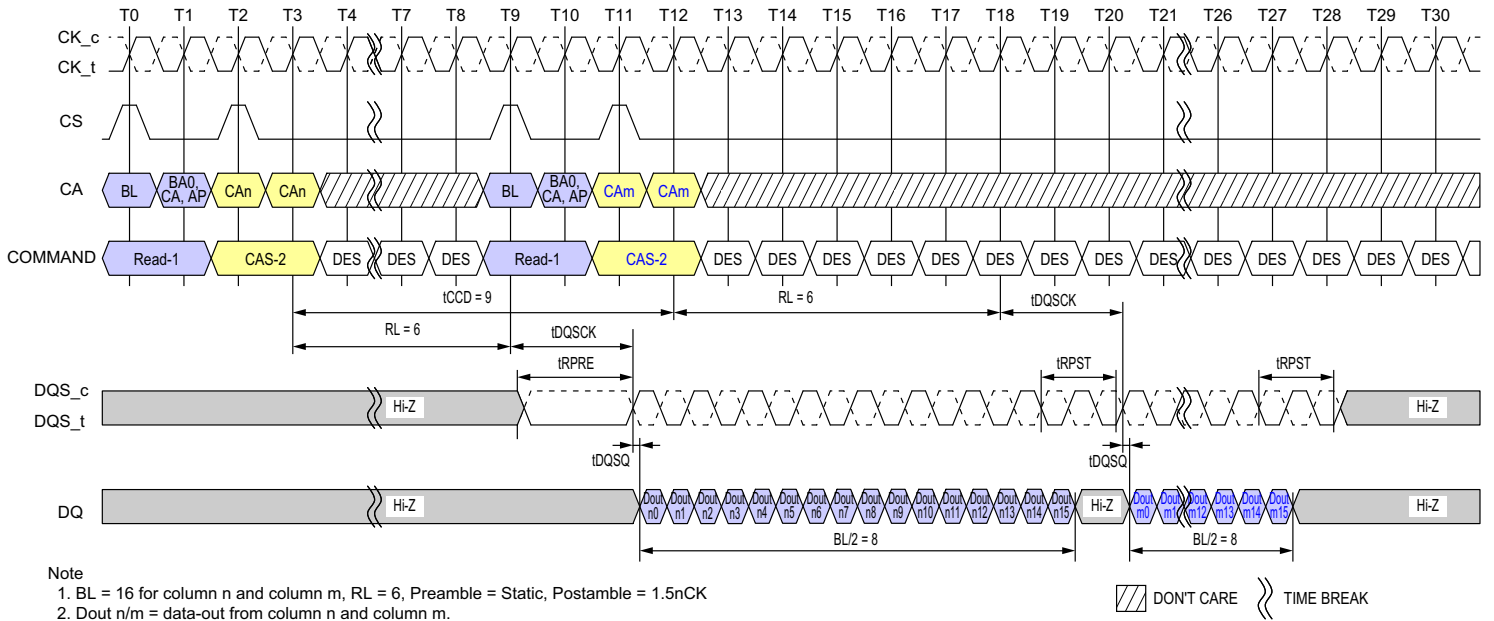

Figure 33 - Consecutive Reads Operation: tCCD = Min + 1, Preamble = Static, 1.5nCK Postamble

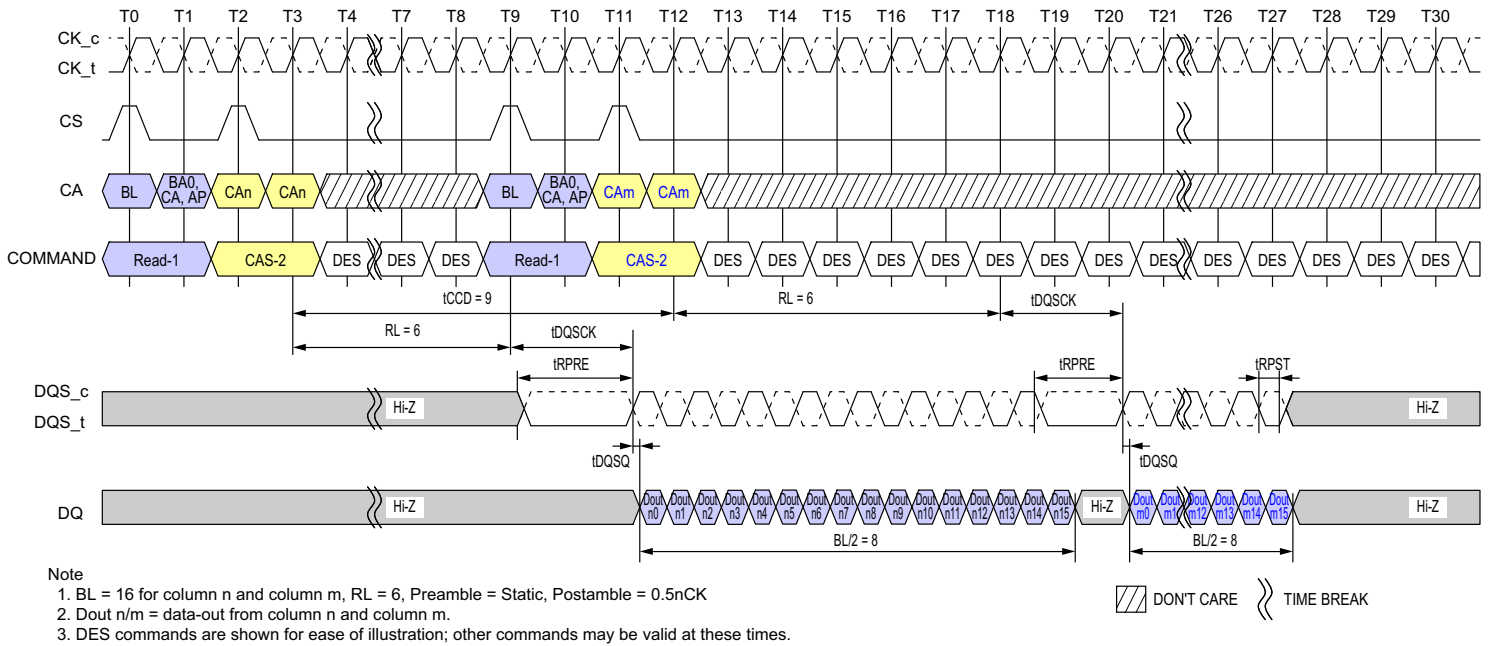

Figure 34 - Consecutive Reads Operation: tCCD = Min + 1, Preamble = Static, 0.5nCK Postamble

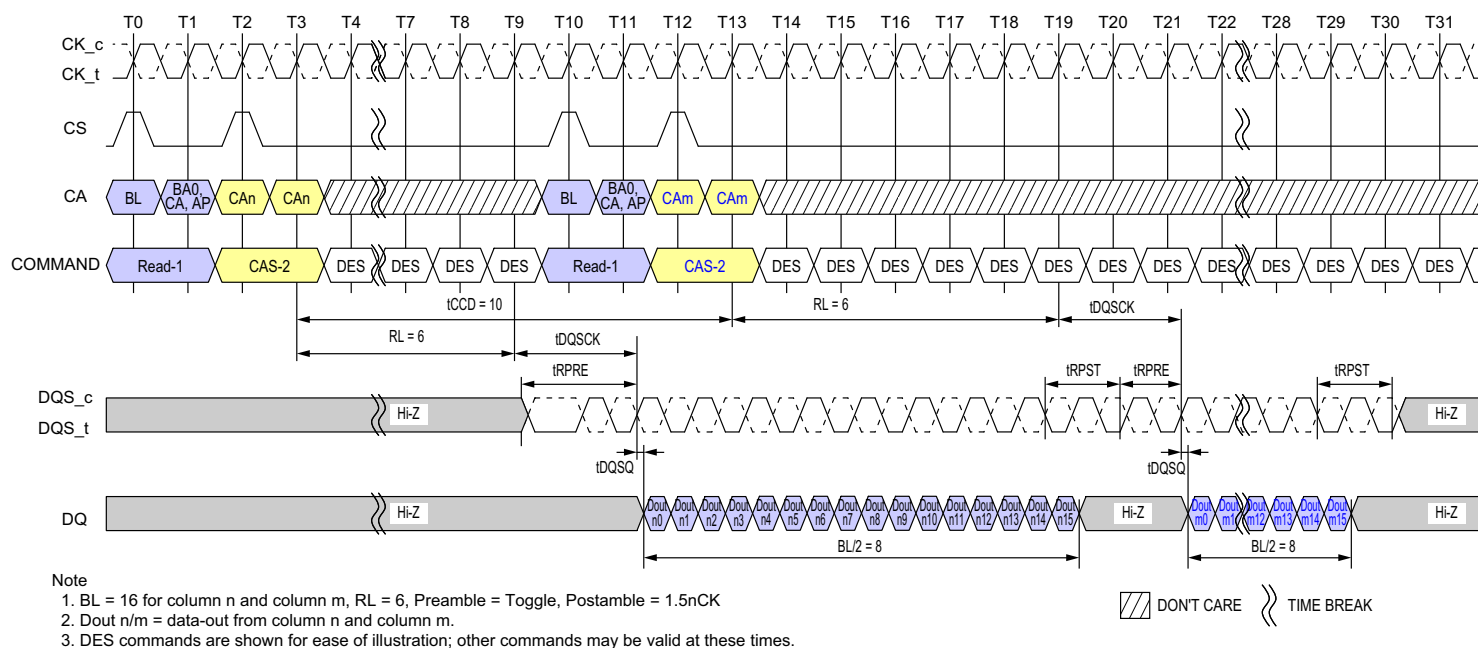

Figure 35 - Consecutive Reads Operation: tCCD = Min +2, Preamble = Toggle, 1.5nCK Postamble

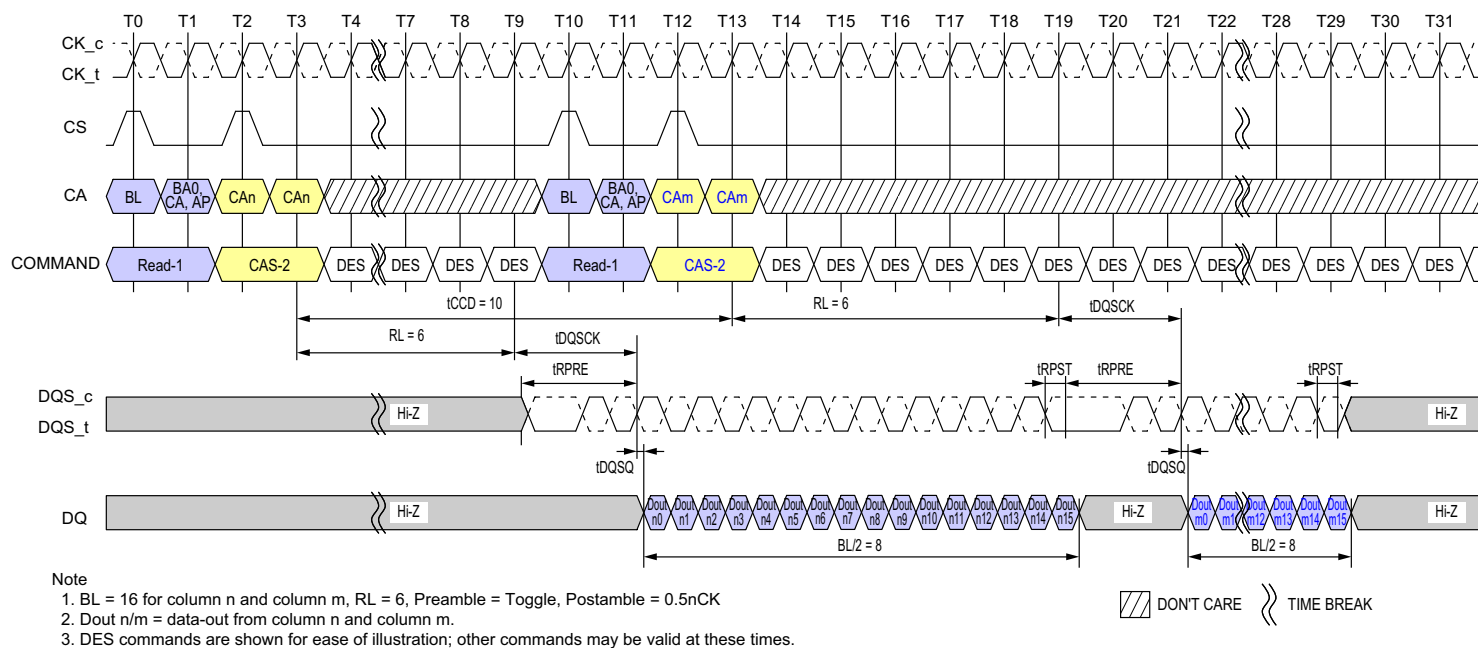

Figure 36 - Consecutive Reads Operation: tCCD = Min +2, Preamble = Toggle, 0.5nCK Postamble

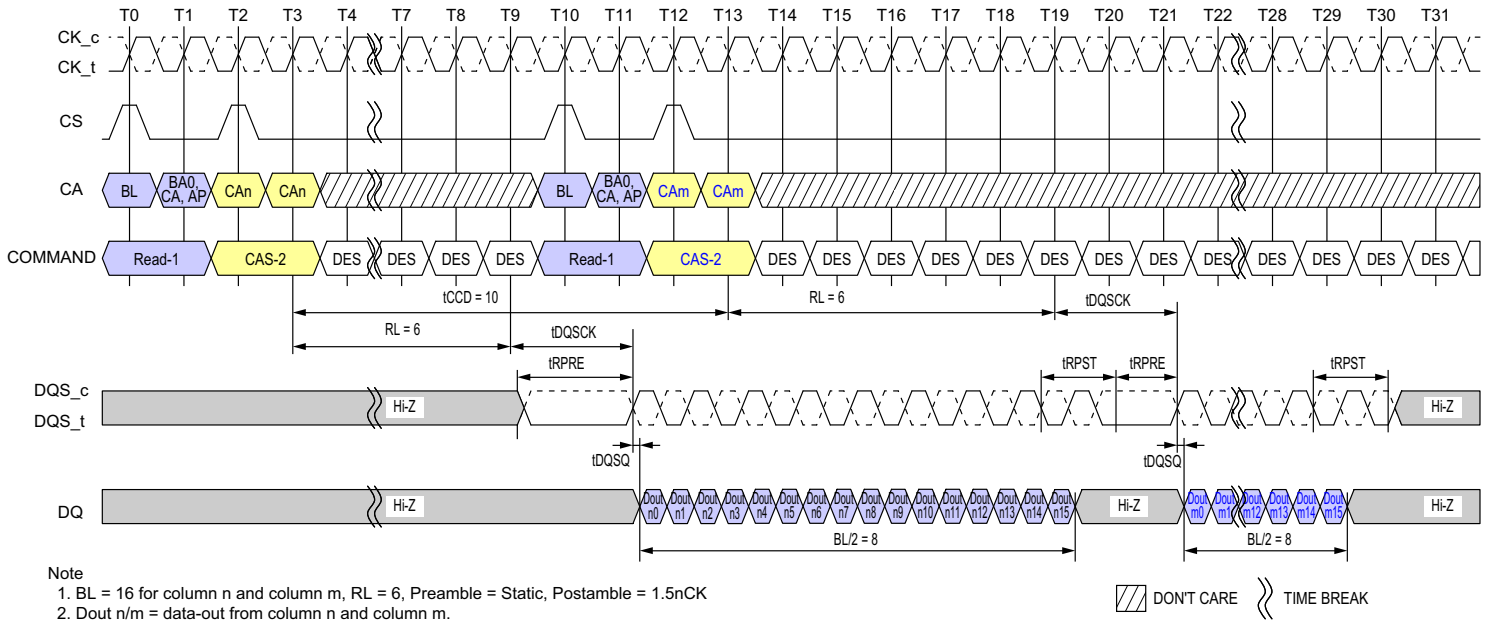

Figure 37 - Consecutive Reads Operation: tCCD = Min + 2, Preamble = Static, 1.5nCK Postamble

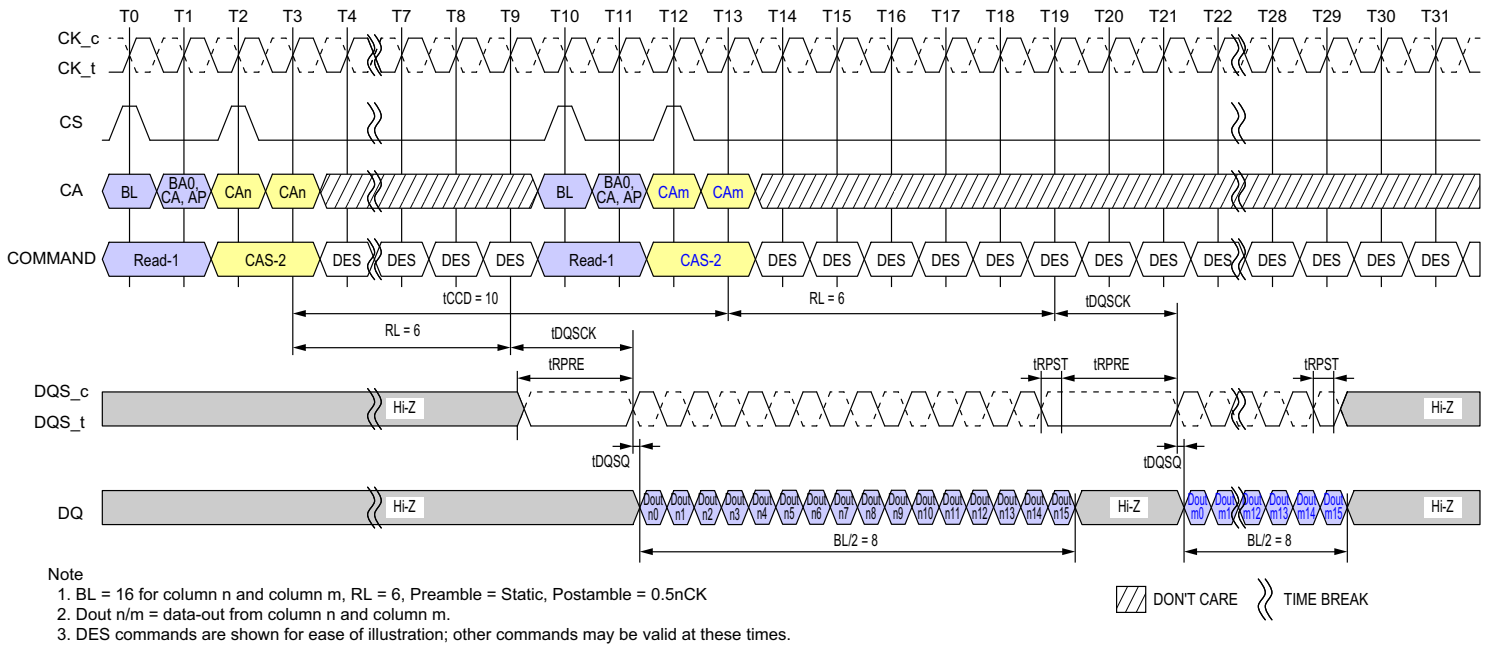

Figure 38 - Consecutive Reads Operation: tCCD = Min + 2, Preamble = Static, 0.5nCK Postamble

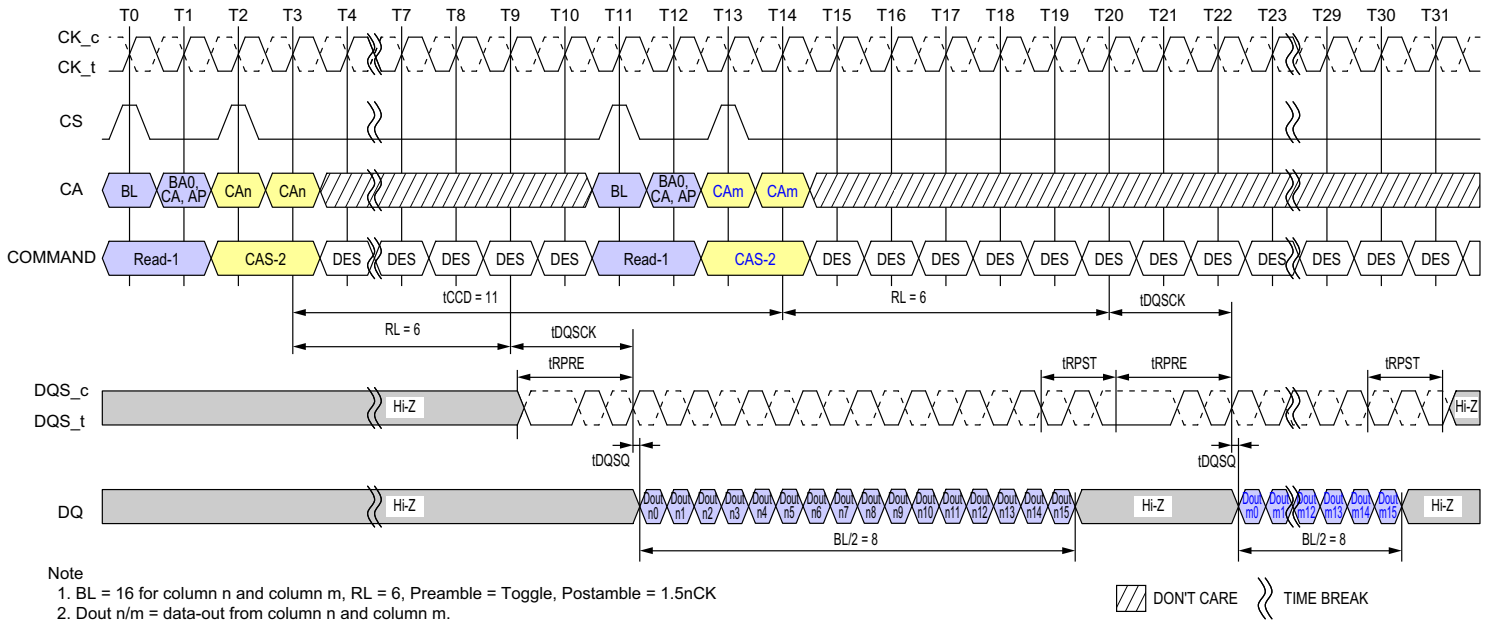

Figure 39 - Consecutive Reads Operation: tCCD = Min +3, Preamble = Toggle, 1.5nCK Postamble

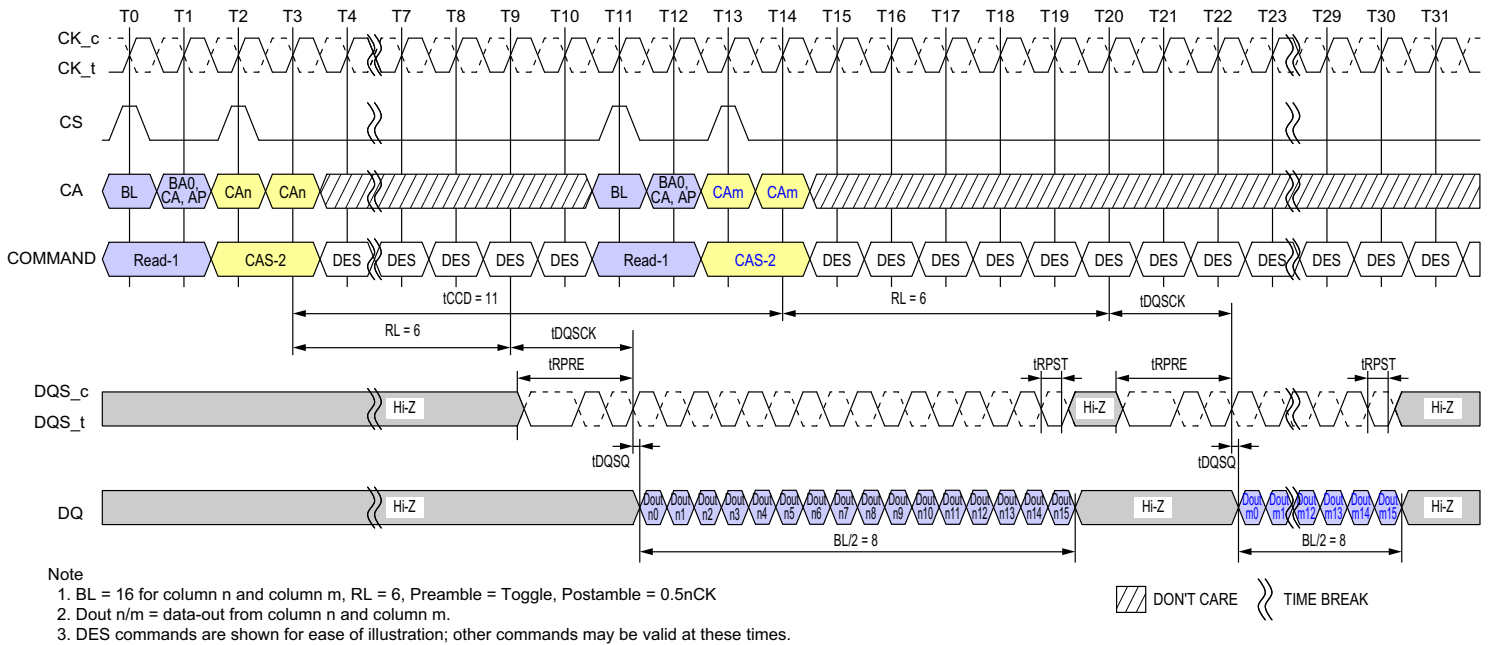

Figure 40 - Consecutive Reads Operation: tCCD = Min +3, Preamble = Toggle, 0.5nCK Postamble

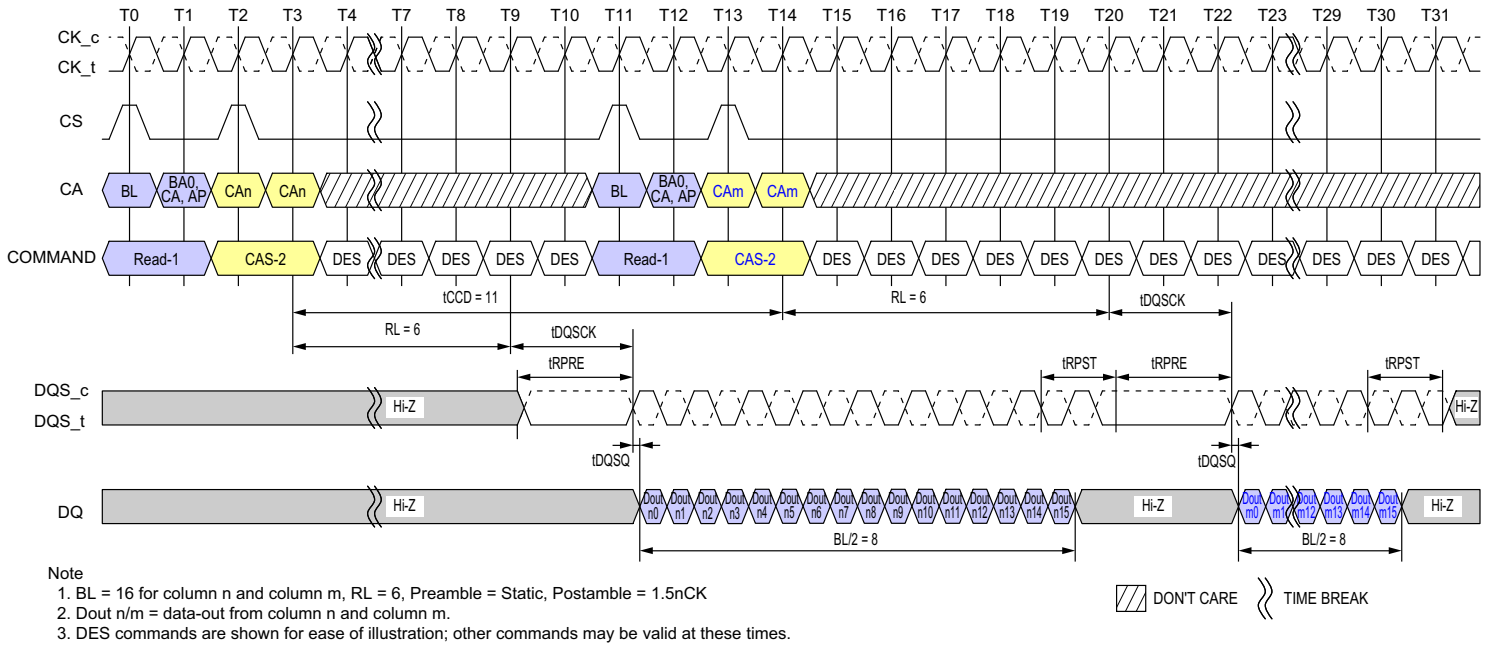

Figure 41 - Consecutive Reads Operation: tCCD = Min +3, Preamble = Static, 1.5nCK Postamble

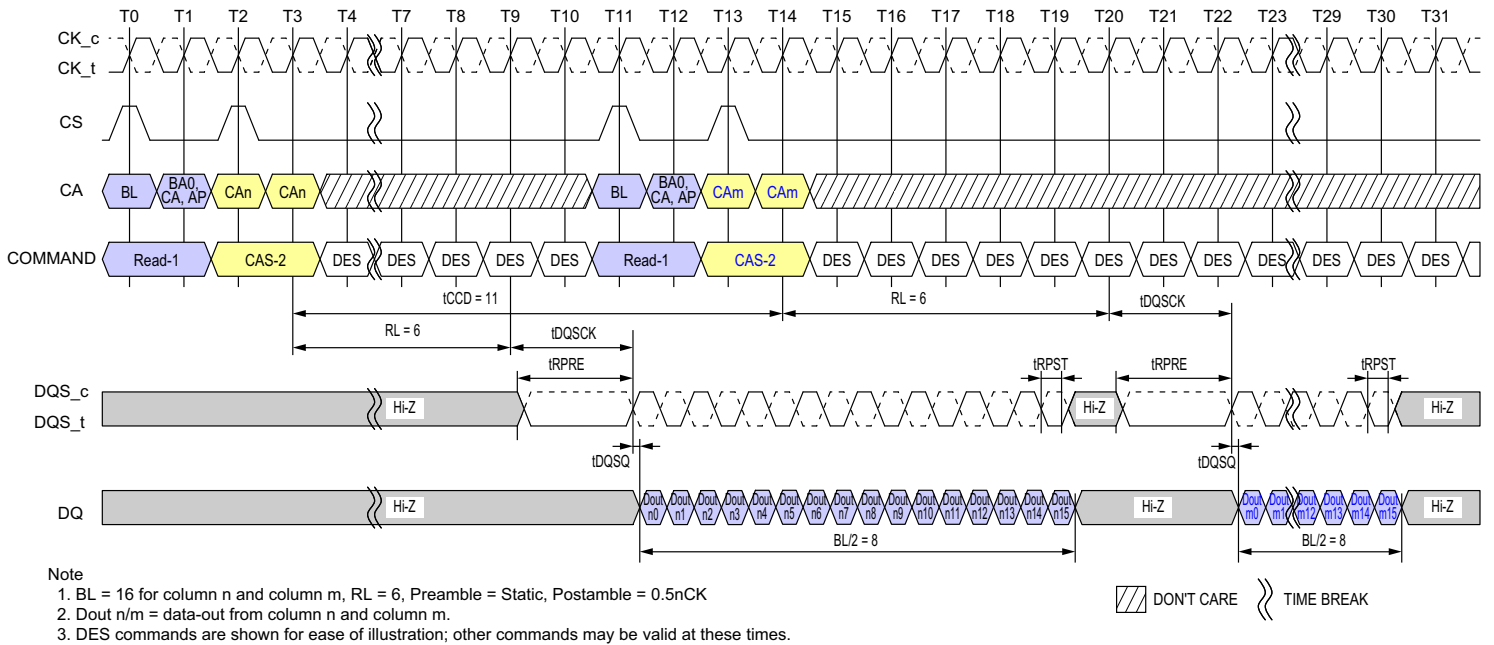

Figure 42 - Consecutive Reads Operation: tCCD = Min +3, Preamble = Static, 0.5nCK Postamble

2.15.2. Write to Write operation

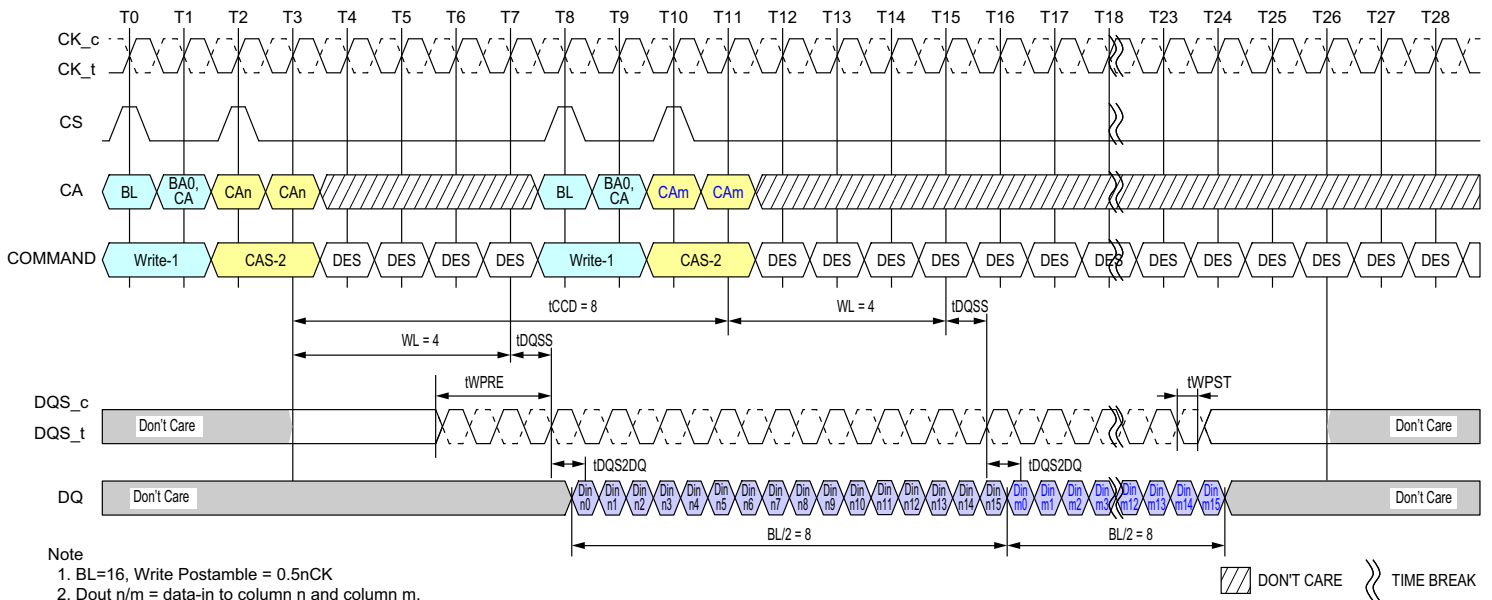

Figure 43 - Seamless Writes Operation: tCCD = Min, 0.5nCK Postamble

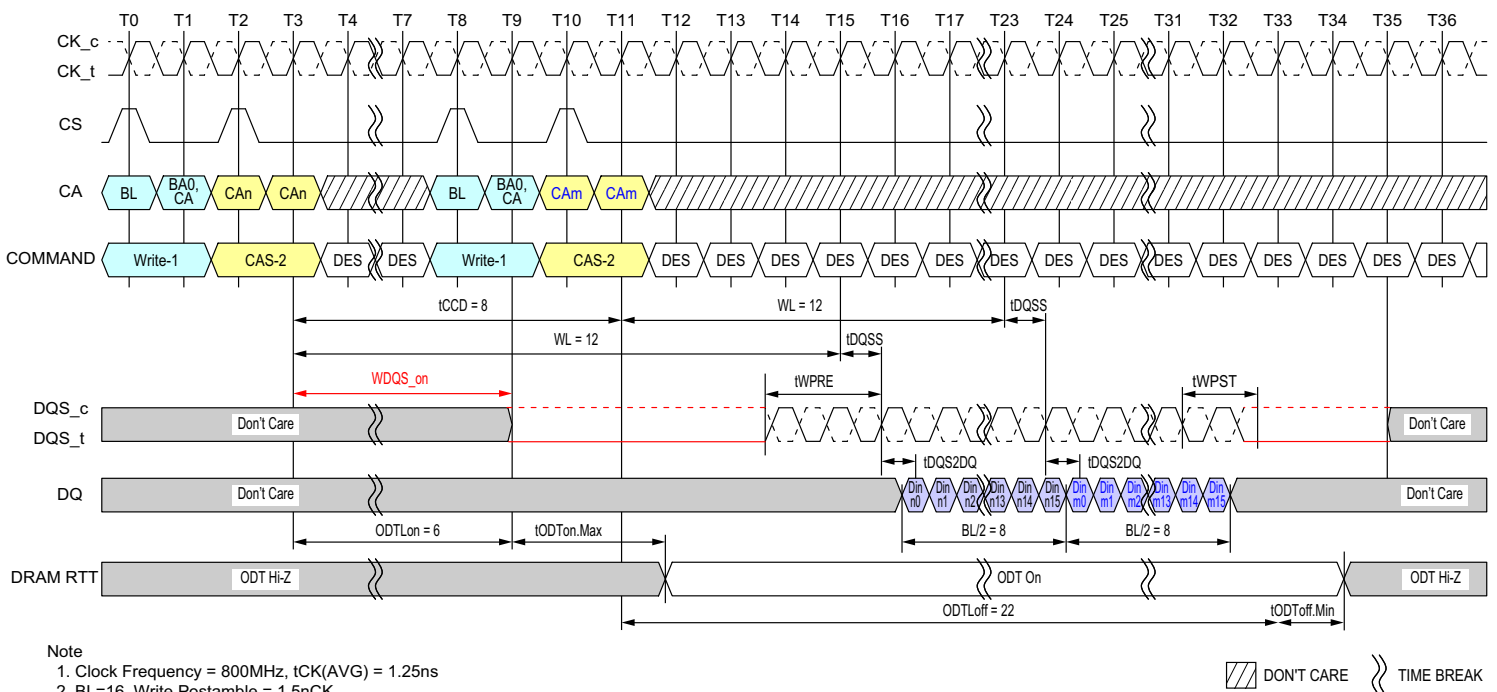

Figure 44 - Seamless Writes Operation: tCCD = Min, 1.5nCK Postamble, 533MHz < Clock Freq. ≤ 800MHz, ODT Worst Timing Case

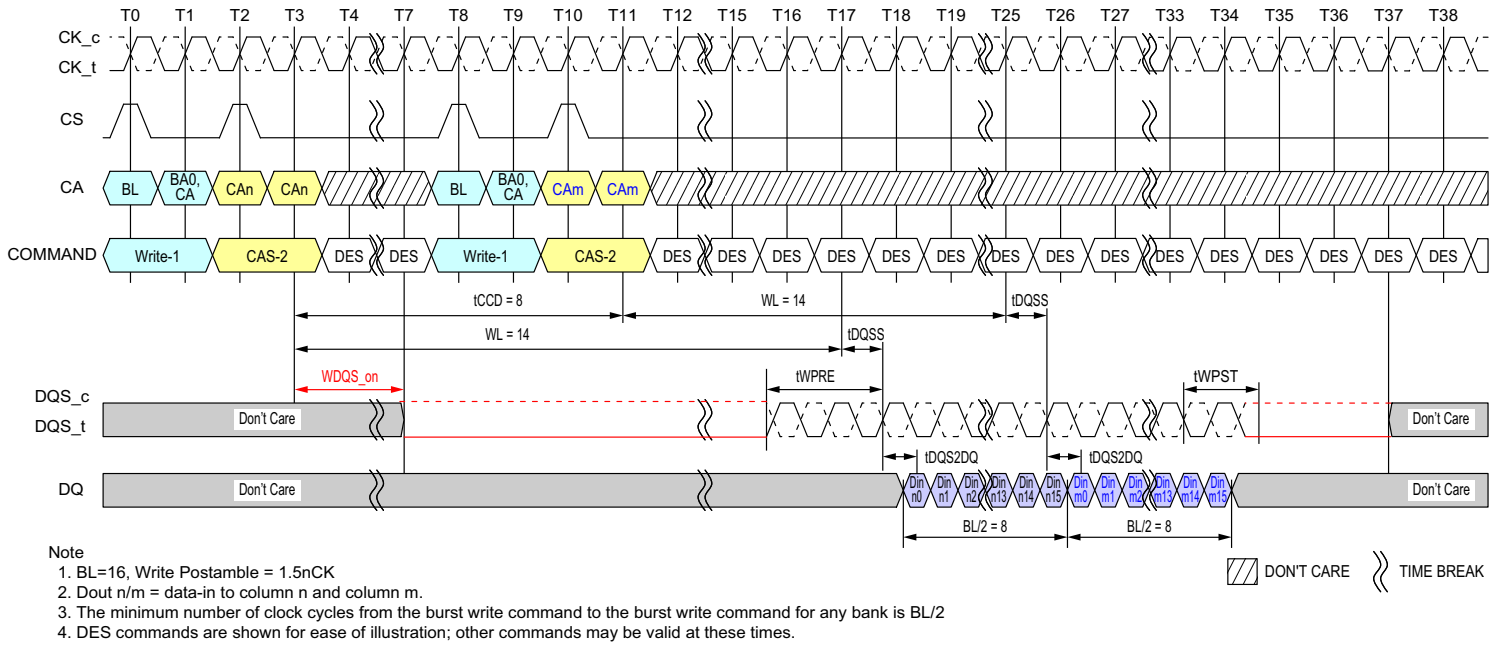

Figure 45 - Seamless Writes Operation: tCCD = Min, 1.5nCK Postamble

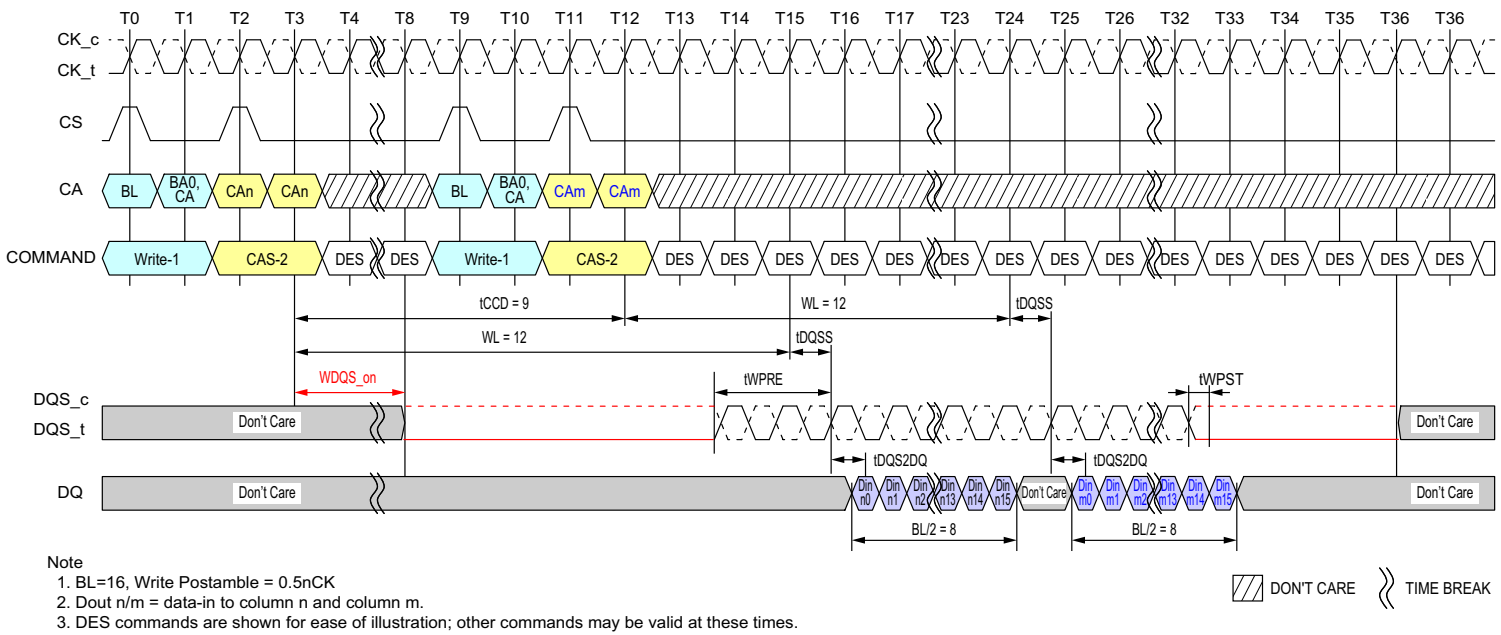

Figure 46 - Consecutive Writes Operation: tCCD = Min + 1, 0.5nCK Postamble

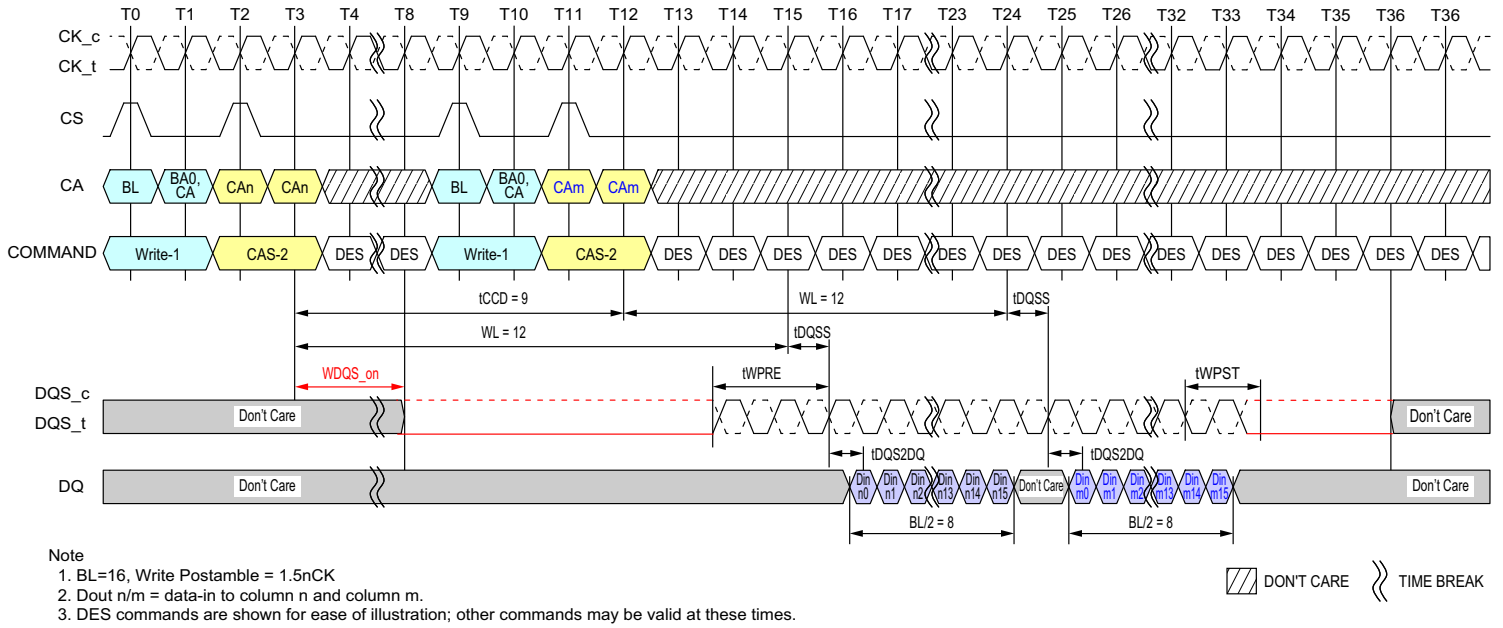

Figure 47 - Consecutive Writes Operation: $t_{CCD} = \text{Min} + 1, 1.5n\text{CK}$ Postamble

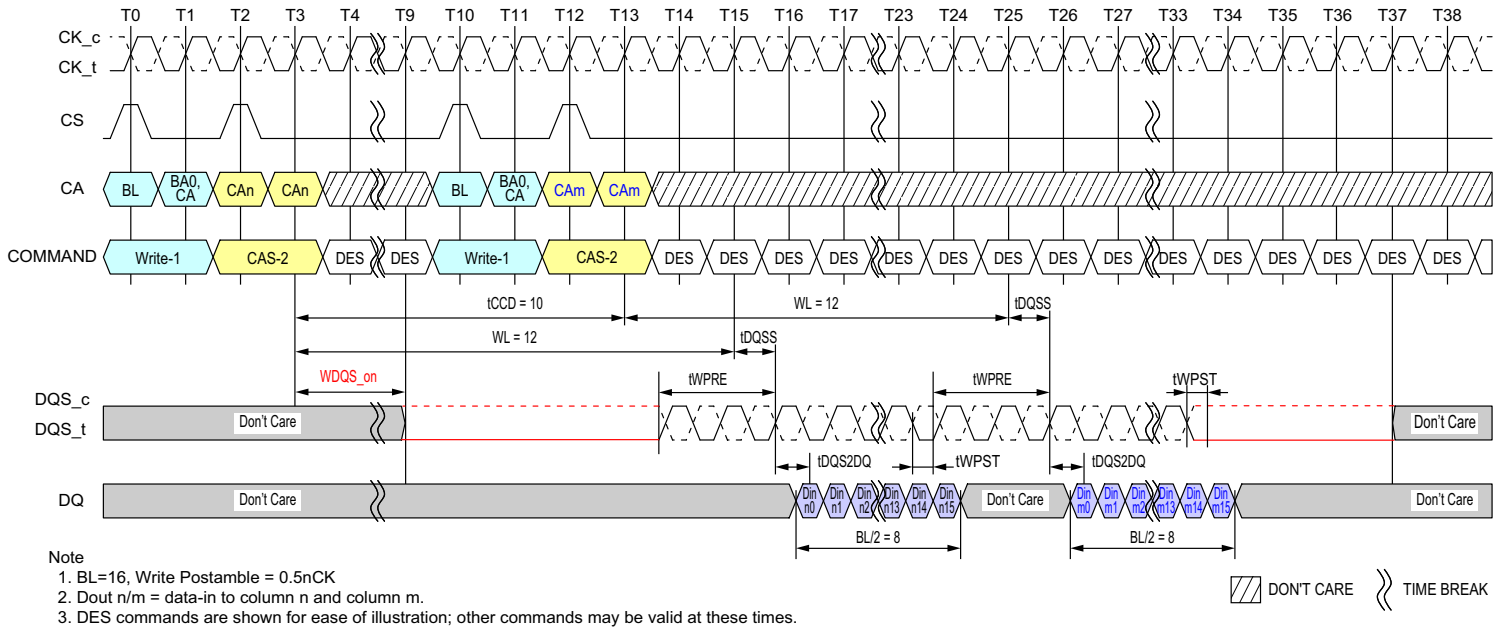

Figure 48 - Consecutive Writes Operation: $t_{CCD} = \text{Min} + 2, 0.5n\text{CK}$ Postamble

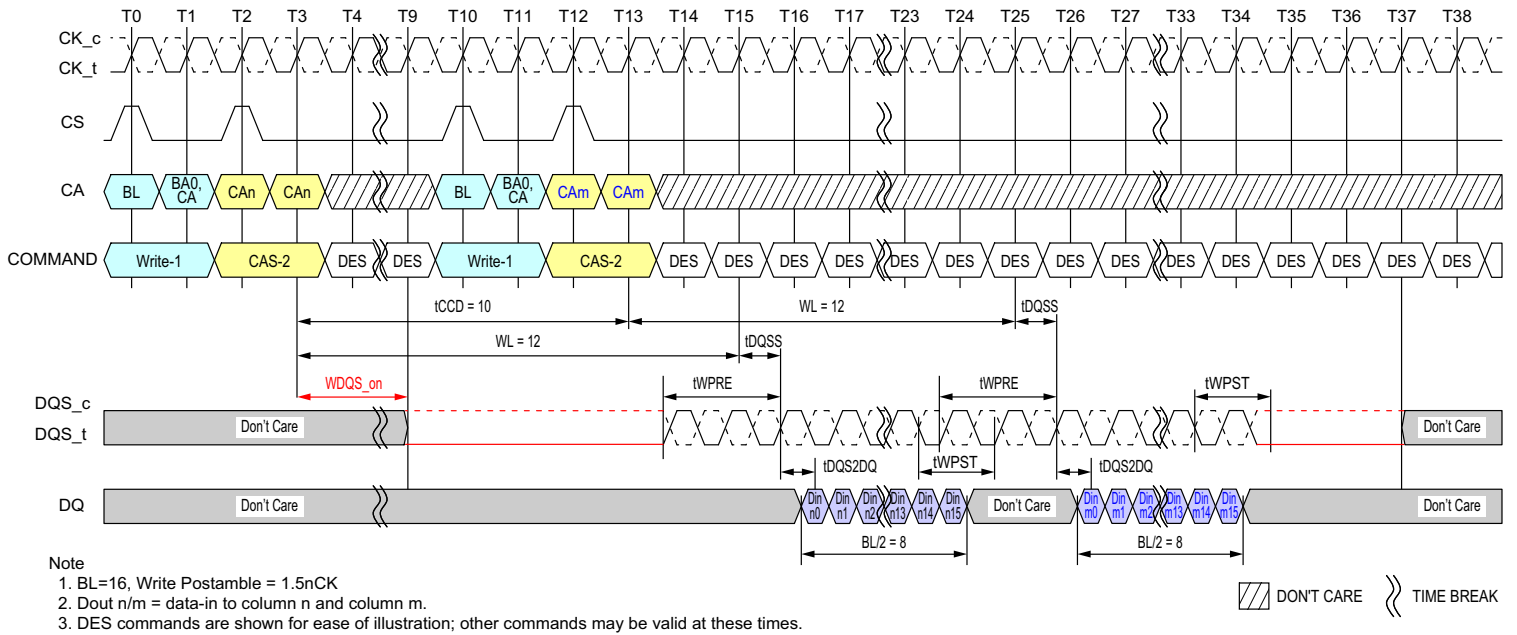

Figure 49 - Consecutive Writes Operation: $t_{CCD} = \text{Min} + 2, 1.5nCK$ Postamble

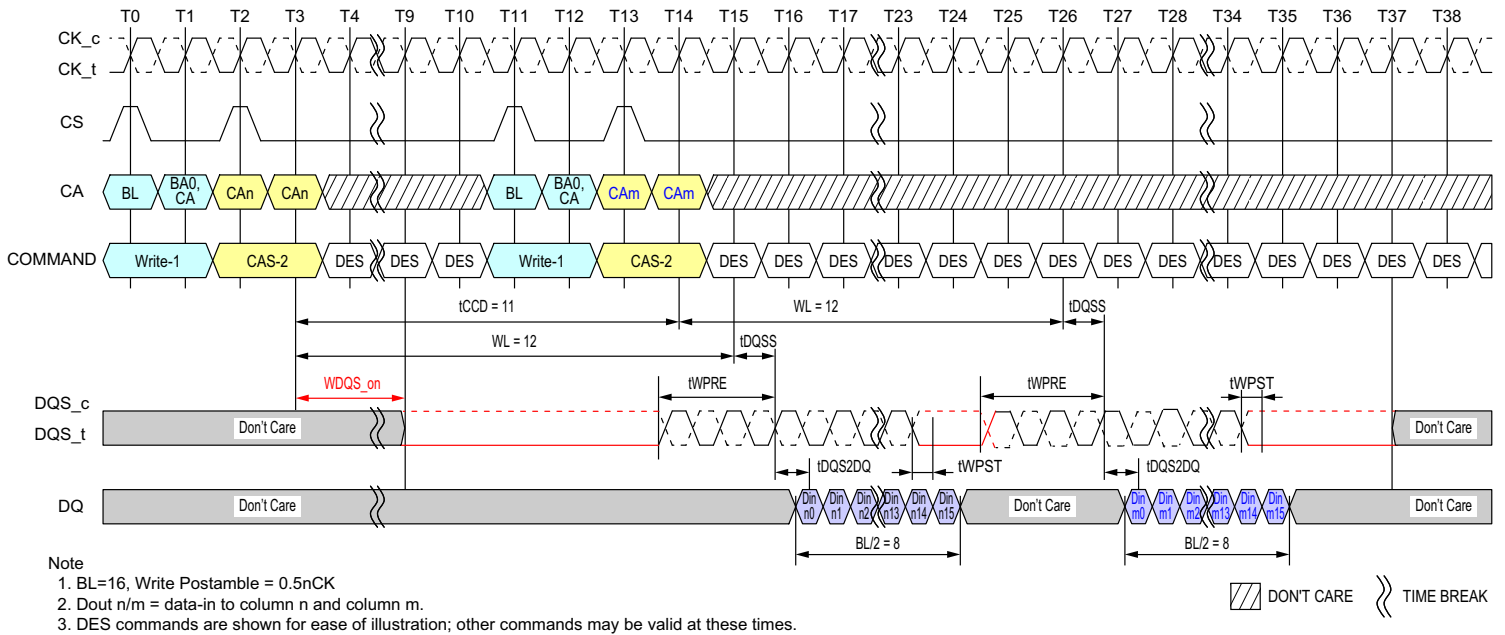

Figure 50 - Consecutive Writes Operation: $t_{CCD} = \text{Min} + 3, 0.5nCK$ Postamble

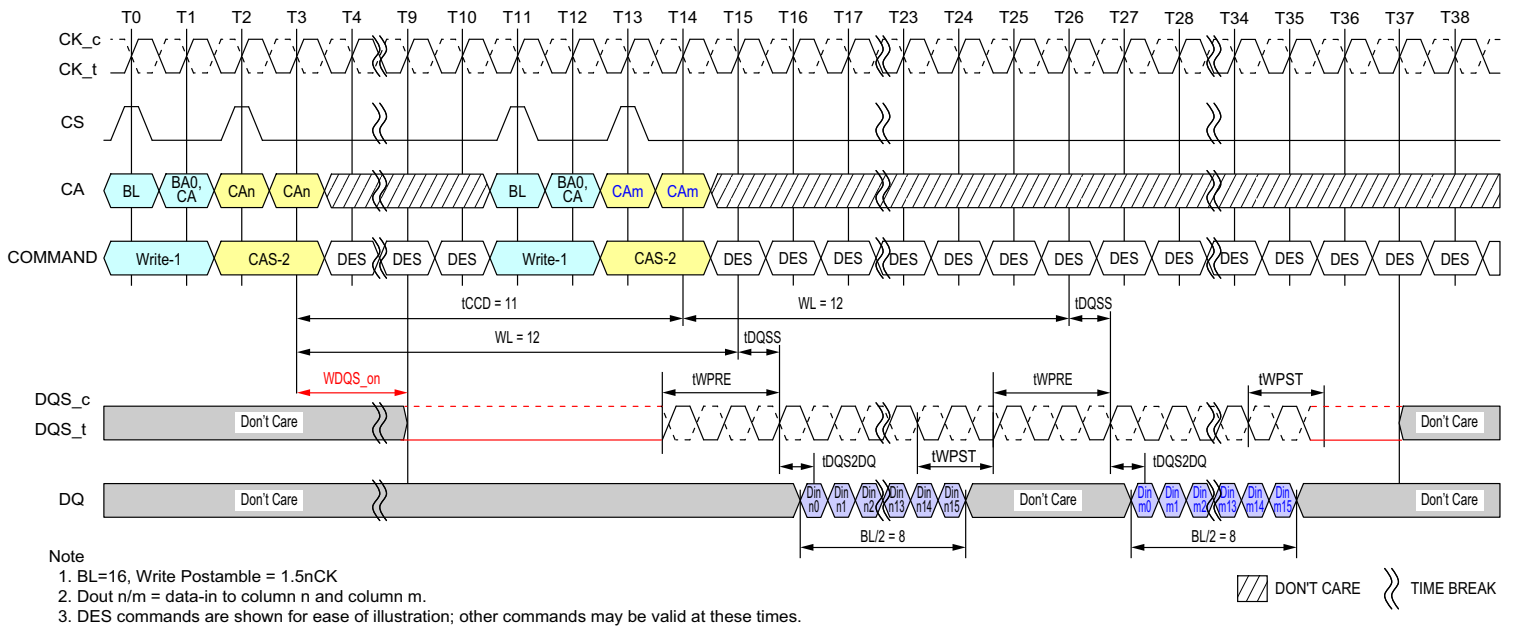

Figure 51 - Consecutive Writes Operation: $t_{CCD} = \text{Min} + 3, 1.5nCK$ Postamble

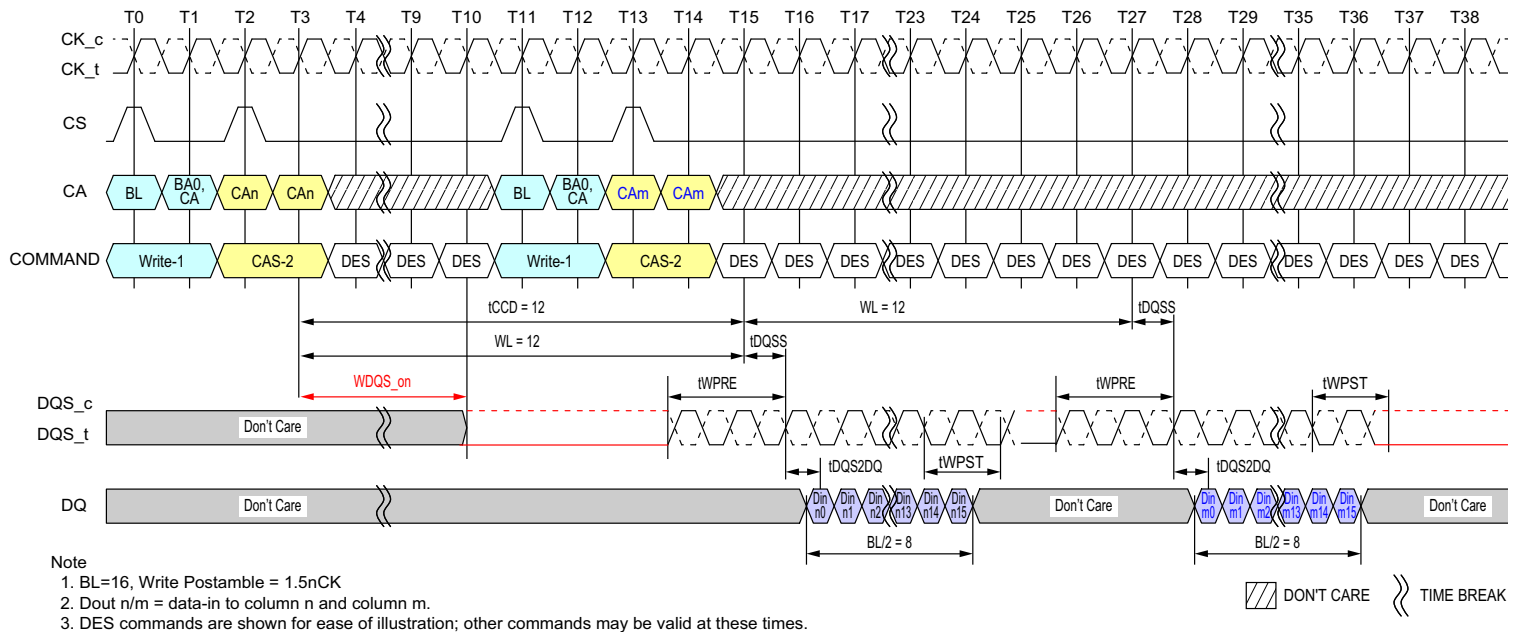
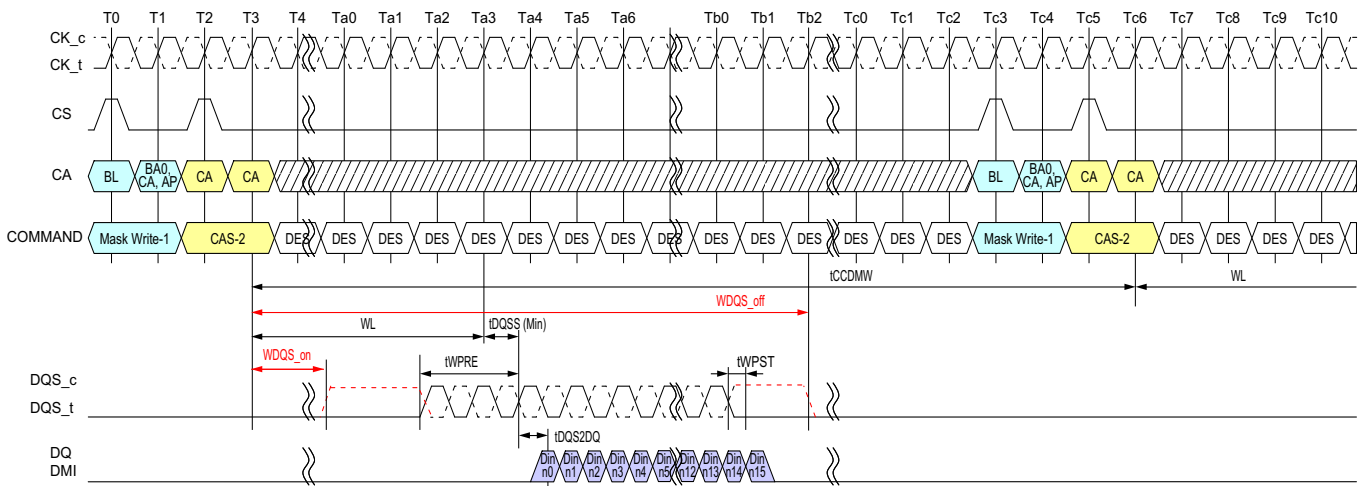

Figure 52 - Consecutive Writes Operation: $t_{CCD} = \text{Min} + 4, 1.5nCK$ Postamble

2.16. Masked Write Operation

The LPDDR4-SDRAM requires that Write operations which include a byte mask anywhere in the burst sequence must use the Masked Write command. This allows the DRAM to implement efficient data protection schemes based on larger data blocks. The Masked Write-1 command is used to begin the operation, followed by a CAS-2 command. A Masked Write command to the same bank cannot be issued until t_{CCDMW} later, to allow the LPDDR4-SDRAM to finish the internal Read-Modify-Write. One Data Mask-Invert (DMI) pin is provided per byte lane, and the Data Mask-Invert timings match data bit (DQ) timing. See the section on "Data Mask Invert" for more information on the use of the DMI signal.



Note

1. BL=16, Write Postamble = 0.5nCK, DQ/DQS: VSSQ termination
2. Din n = data-in to column n
3. Mask-Write supports only BL16 operations. For BL32 configuration, the system needs to insert only 16 bit wide data for masked write operation.
4. DES commands are shown for ease of illustration; other commands may be valid at these time.

▨ DONT CARE ⋈ TIME BREAK

Figure 53 - Masked Write Command - Same Bank

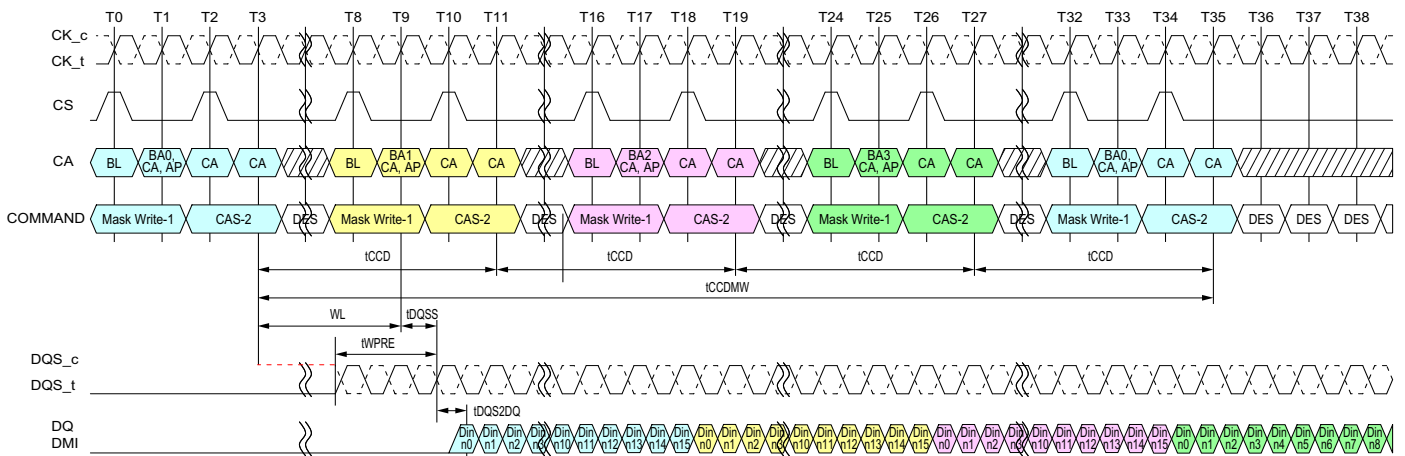

Note

1. BL=16, DQ/DQS/DMI: VSSQ termination
2. Din n = data-in to column n
3. Mask-Write supports only BL16 operations. For BL32 configuration, the system needs to insert only 16 bit wide data for masked write operation.
4. DES commands are shown for ease of illustration; other commands may be valid at these time.

▨ DONT CARE ⋈ TIME BREAK

Figure 54 - Masked Write Command - Different Bank

2.16.1. Masked Write Timing constraints
Table 32 - Masked Write Timing constraints - Same bank : DQ ODT is Disabled

Next CMD Current CMD	Activate	Read (BL16 or 32)	Write (BL16 or 32)	Masked Write	Precharge
Active	illegal	RU(tRCD/tCK)	RU(tRCD/tCK)	RU(tRCD/tCK)	RU(tRAS/tCK)
Read with BL = 16	illegal	8 ¹⁾	RL+RU(tDQSCK(max)/ tCK) +BL/2- WL+tWPRE+RD(tRPST)	RL+RU(tDQSCK(max)/ tCK) +BL/2- WL+tWPRE+RD(tRPST)	BL/2+max{(8, RU(tRTP/ tCK))-8}
Read with BL = 32	illegal	16 ²⁾	RL+RU(tDQSCK(max)/ tCK) +BL/2- WL+tWPRE+RD(tRPST)	RL+RU(tDQSCK(max)/ tCK) +BL/2- WL+tWPRE+RD(tRPST)	BL/2+max{(8, RU(tRTP/ tCK))-8}
Write with BL = 16	illegal	WL+1+BL/2 +RU(tWTR/tCK)	8 ¹⁾	tCCDMW ³⁾	WL+ 1 + BL/2+RU(tWR/ tCK)
Write with BL = 32	illegal	WL+1+BL/2 +RU(tWTR/tCK)	16 ²⁾	tCCDMW +8 ⁴⁾	WL+ 1 + BL/2+RU(tWR/ tCK)
Masked Write	illegal	WL+1+BL/2 +RU(tWTR/tCK)	tCCD	tCCDMW ³⁾	WL+ 1 + BL/2 +RU(tWR/tCK)
Precharge	RU(tRP/tCK), RU(tRPab/tCK)	illegal	illegal	illegal	4

Notes

1. In the case of BL = 16, tCCD is 8*tCK.
2. In the case of BL = 32, tCCD is 16*tCK.
3. tCCDMW = 32*tCK (4*tCCD at BL=16)
4. Write with BL=32 operation has 8*tCK longer than BL =16.
5. tRPST values depend on MR1-OP[7] respectively.

Table 33 - Masked Write Timing constraints - Same bank : DQ ODT is Enabled

Next CMD Current CMD	Activate	Read (BL16 or 32)	Write (BL16 or 32)	Masked Write	Precharge
Read with BL = 16	illegal	8 ¹⁾	RL+RU(tDQSCK(max)/ tCK)+BL/2+RD(tRPST)- ODTLon-RD(tODTon,min/ tCK)+1	RL+RU(tDQSCK(max)/ tCK)+BL/2+RD(tRPST)- ODTLon-RD(tODTon,min/ tCK)+1	BL/2+max{(8, RU(tRTP/ tCK))-8}
Read with BL = 32	illegal	16 ²⁾	RL+RU(tDQSCK(max)/ tCK)+BL/2+RD(tRPST)- ODTLon-RD(tODTon,min/ tCK)+1	RL+RU(tDQSCK(max)/ tCK)+BL/2+RD(tRPST)- ODTLon-RD(tODTon,min/ tCK)+1	BL/2+max{(8, RU(tRTP/ tCK))-8}

Notes

1. In the case of BL = 16, tCCD is 8*tCK.
2. In the case of BL = 32, tCCD is 16*tCK.
3. The rest of the timing is same as DQ ODT is Disable case
4. tRPST values depend on MR1-OP[7] respectively.

Table 34 - Masked Write Timing constraints - Different bank : DQ ODT is Disabled

Next CMD Current CMD	Activate	Read (BL16 or 32)	Write (BL16 or 32)	Masked Write (BL16)	Precharge
Active	RU(tRRD/tCK)	4	4	4	2
Read with BL = 16	4	8 ¹⁾	RL+RU(tDQSCK(max)/ tCK) +BL/2- WL+tWPRE+RD(trPST)	RL+RU(tDQSCK(max)/ tCK) +BL/2- WL+tWPRE+RD(trPST)	2
Read with BL = 32	4	16 ²⁾	RL+RU(tDQSCK(max)/ tCK) +BL/2- WL+tWPRE+RD(trPST)	RL+RU(tDQSCK(max)/ tCK) +BL/2- WL+tWPRE+RD(trPST)	2
Write with BL = 16	4	WL+1+BL/2 +RU(tWTR/tCK)	8 ¹⁾	8 ¹⁾	2
Write with BL = 32	4	WL+1+BL/2 +RU(tWTR/tCK)	16 ²⁾	16 ²⁾	2
Masked Write	4	WL+1+BL/2 +RU(tWTR/tCK)	8 ¹⁾	8 ¹⁾	2
Precharge	4	4	4	4	4

Notes:

- 1) In the case of BL = 16, tCCD is 8*tCK.
- 2) In the case of BL = 32, tCCD is 16*tCK.
- 3) trPST values depend on MR1-OP[7] respectively

Table 35 - Masked Write Timing constraints - Different bank : DQ ODT is Enabled

Next CMD Current CMD	Activate	Read (BL16 or 32)	Write (BL16 or 32)	Masked Write (BL16)	Precharge
Read with BL = 16	4	8 ¹⁾	RL+RU(tDQSCK(max)/tCK)+BL/ 2+RD(trPST)-ODTLon- RD(tODTon,min/tCK)+1	RL+RU(tDQSCK(max)/tCK)+BL/ 2+RD(trPST)-ODTLon- RD(tODTon,min/tCK)+1	2
Read with BL = 32	4	16 ²⁾	RL+RU(tDQSCK(max)/tCK)+BL/ 2+RD(trPST)-ODTLon- RD(tODTon,min/tCK)+1	RL+RU(tDQSCK(max)/tCK)+BL/ 2+RD(trPST)-ODTLon- RD(tODTon,min/tCK)+1	2

Notes:

- 1) In the case of BL = 16, tCCD is 8*tCK.
- 2) In the case of BL = 32, tCCD is 16*tCK.
- 3) The rest of the timing is same as DQ ODT is Disable case
- 4) trPST values depend on MR1-OP[7] respectively.

2.17. LPDDR4 Data Mask (DM) and Data Bus Inversion (DBI_{dc}) Function

LPDDR4 SDRAM supports the function of Data Mask and Data Bus inversion. Details are as follows:

- LPDDR4 device supports Data Mask (DM) function for Write operation.
- LPDDR4 device supports Data Bus Inversion (DBI_{dc}) function for Write and Read operation.
- LPDDR4 supports DM and DBI_{dc} function with a byte granularity.
- DBI_{dc} function during Write or Masked Write can be enabled or disabled through MR3 OP[7].
- DBI_{dc} function during Read can be enabled or disabled through MR3 OP[6].
- DM function during Masked Write can be enabled or disabled through MR13 OP[5].
- LPDDR4 device has one Data Mask Inversion (DMI) signal pin per byte; total of 2 DMI signals per channel.
- DMI signal is a bi-directional DDR signal and is sampled along with the DQ signals for Read and Write or Masked Write operation.

There are eight possible combinations for LPDDR4 device with DM and DBI_{dc} function. Below table describes the functional behavior for all combinations.

Table 36 - Function Behaviour of DMI Signal During Write, Masked Write and Read Operation

DM Function	Write DBI _{dc} Function	Read DBI _{dc} Function	DMI Signal during Write Command	DMI Signal during Masked Write Command	DMI Signal during Read	DMI Signal during MPC [WR FIFO]	DMI Signal during MPC [RD FIFO]	DMI Signal during MPC [DQ Read calibration]	DMI Signal during MRR Command
Disable	Disable	Disable	Note: 1	Note: 1, 3	Note: 2	Note: 1	Note: 2	Note: 2	Note: 2
Disable	Enable	Disable	Note: 4	Note: 3	Note: 2	Note: 9	Note: 10	Note: 11	Note: 2
Disable	Disable	Enable	Note: 1	Note: 3	Note: 5	Note: 9	Note: 10	Note: 11	Note: 12
Disable	Enable	Enable	Note: 4	Note: 3	Note: 5	Note: 9	Note: 10	Note: 11	Note: 12
Enable	Disable	Disable	Note: 6	Note: 7	Note: 2	Note: 9	Note: 10	Note: 11	Note: 2
Enable	Enable	Disable	Note: 4	Note: 8	Note: 2	Note: 9	Note: 10	Note: 11	Note: 2
Enable	Disable	Enable	Note: 6	Note: 7	Note: 5	Note: 9	Note: 10	Note: 11	Note: 12
Enable	Enable	Enable	Note: 4	Note: 8	Note: 5	Note: 9	Note: 10	Note: 11	Note: 12

1. DMI input signal is a don't care. DMI input receivers are turned OFF.
2. DMI output drivers are turned OFF.
3. Masked Write Command is not allowed and is considered an illegal command as DM function is disabled.
4. DMI signal is treated as DBI signal and it indicates whether DRAM needs to invert the Write data received on DQs within a byte. The LPDDR4 device inverts Write data received on the DQ inputs in case DMI was sampled HIGH, or leaves the Write data non-inverted in case DMI was sampled LOW.
5. The LPDDR4 DRAM inverts Read data on its DQ outputs associated within a byte and drives DMI signal HIGH when the number of '1' data bits within a given byte lane is greater than four; otherwise the DRAM does not invert the read data and drives DMI signal LOW.
6. The LPDDR4 DRAM does not perform any mask operation when it receives Write command. During the Write burst associated with Write command, DMI signal must be driven LOW.
7. The LPDDR4 DRAM requires an explicit Masked Write command for all masked write operations. DMI signal is treated as DM signal and it indicates which bit time within the burst is to be masked. When DMI signal is HIGH, DRAM masks that bit time across all DQs associated within a byte. All DQ input signals within a byte are don't care (either HIGH or LOW) when DMI signal is HIGH. When DMI signal is LOW, the LPDDR4 DRAM does not perform mask operation and data received on DQ input is written to the array.
8. The LPDDR4 DRAM requires an explicit Masked Write command for all masked write operations. The LPDDR4 device masks the Write data received on the DQ inputs if the total count of '1' data bits on DQ[2:7] or DQ[10:15] (for Lower Byte or Upper Byte respectively) is equal to or greater than five and DMI signal is LOW. Otherwise the LPDDR4 DRAM does not perform mask operation and treats it as a legal DBI pattern; DMI signal is treated as DBI signal and data received on DQ input is written to the array.

9. DMI signal is treated as a training pattern. The LPDDR4 DRAM does not perform any mask operation and does not invert Write data received on the DQ inputs.

10. DMI signal is treated as a training pattern. The LPDDR4 DRAM returns DMI pattern written in WR FIFO.

11. DMI signal is treated as a training pattern. For more details, see 4.34, RD DQ Calibration.

12. DBI may apply or may not apply during normal MRR. It's vendor specific.

If read DBI is enable with MRS and vendor cannot support the DBI during MRR, DBI pin status should be low.

If read DBI is enable with MRS and vendor can support the DBI during MRR, the LPDDR4 DRAM inverts Mode Register Read data on its DQ outputs associated within a byte and drives DMI signal HIGH when the number of '1' data bits within a given byte lane is greater than four; otherwise the DRAM does not invert the read data and drives DMI signal LOW.

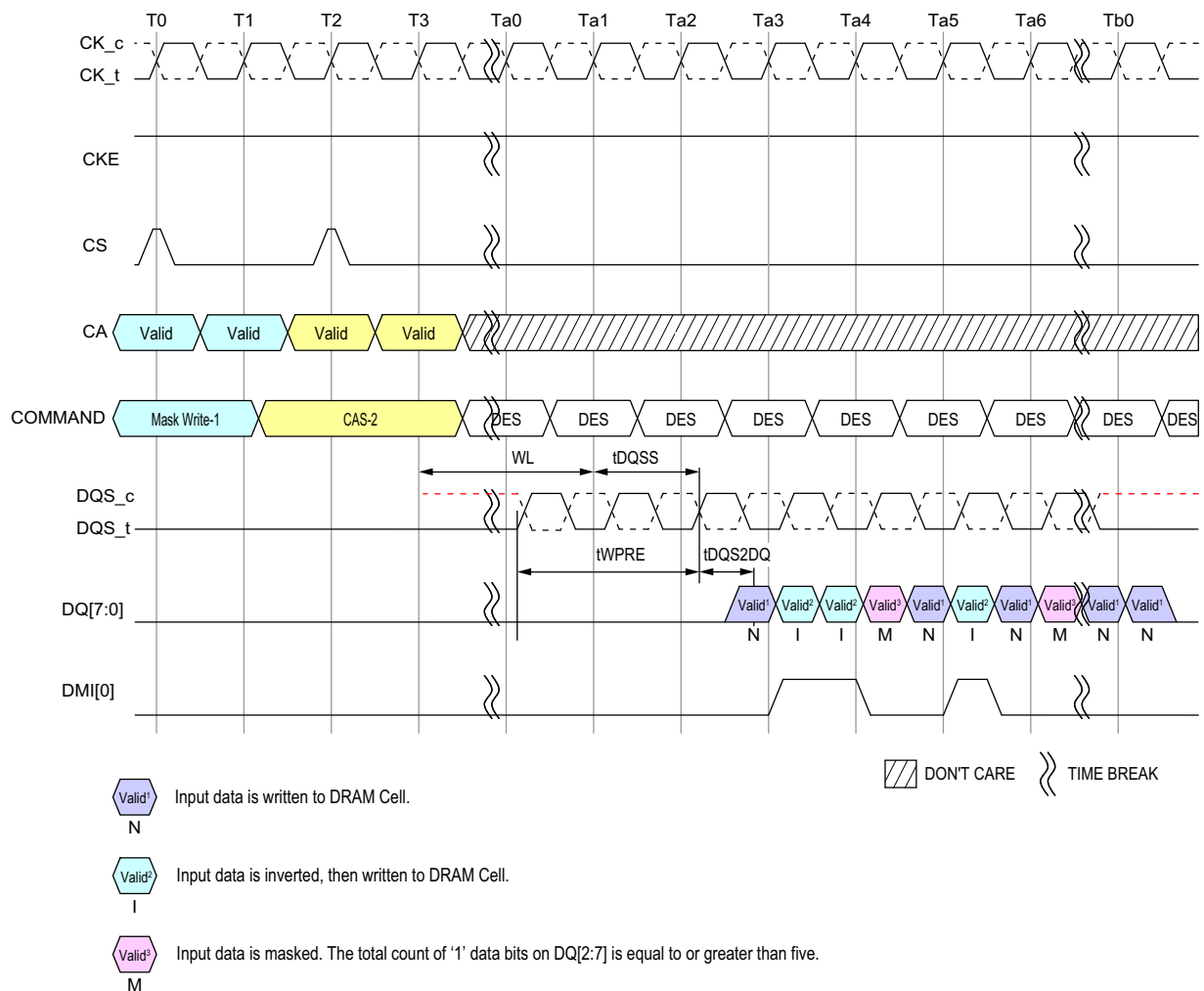

NOTES : 1. Data Mask (DM) is Enable: MR13 OP [5] = 0, Data BUS Inversion (DBI) Write is Enable: MR3 OP[7] = 1

Figure 55 - Masked Write Command w/ Write DBI Enabled; DM Enabled

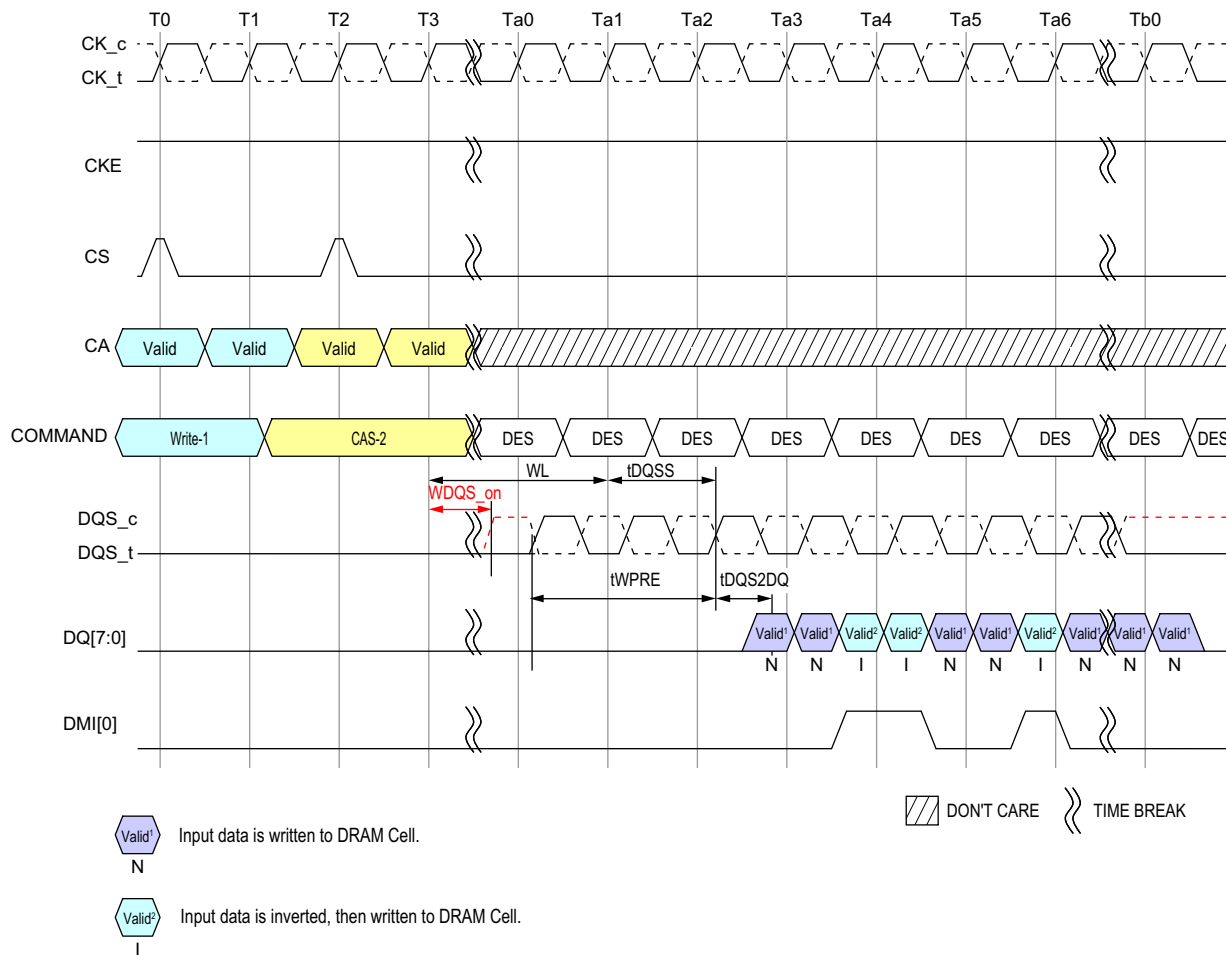

NOTES : 1. Data Mask (DM) is Disable: MR13 OP [5] = 1, Data BUS Inversion (DBI) Write is Enable: MR3 OP[7] = 1

Figure 56 - Write Command w/ Write DBI Enabled; DM Disabled

2.18. Precharge Operation

The PRECHARGE command is used to precharge or close a bank that has been activated. The PRECHARGE command is initiated with CS, and CA[5:0] in the proper state as defined by the Command Truth Table. The PRECHARGE command can be used to precharge each bank independently or all banks simultaneously. The AB flag and the bank address bit are used to determine which bank(s) to precharge. The precharged bank(s) will be available for subsequent row access tRPab after an all bank PRECHARGE command is issued, or tRPpb after a single-bank PRECHARGE command is issued.

To ensure that LPDDR4 devices can meet the instantaneous current demands, the row-precharge time for an all bank PRECHARGE (tRPab) is longer than the per bank precharge time (tRPpb).

Table 37 - Precharge Bank Selection

AB (CA[5], R1)	BA2 (CA[2], R2)	BA1 (CA[1], R2)	BA0 (CA[0], R2)	Precharged Bank(s)
0	0	0	0	Bank 0 Only
0	0	0	1	Bank 1 Only
0	0	1	0	Bank 2 Only
0	0	1	1	Bank 3 Only
0	1	0	0	Bank 4 Only
0	1	0	1	Bank 5 Only
0	1	1	0	Bank 6 Only
0	1	1	1	Bank 7 Only
1	Valid	Valid	Valid	All banks

2.18.1. Burst Read Operation followed by Precharge

The PRECHARGE command can be issued as early as BL/2 clock cycles after a READ command, but PRECHARGE cannot be issued until after tRAS is satisfied. A new bank ACTIVATE command can be issued to the same bank after the row PRECHARGE time (tRP) has elapsed. The minimum READ-to-PRECHARGE time must also satisfy a minimum analog time from the 2nd rising clock edge of the CAS-2 command. tRTP begins BL/2 - 8 clock cycles after the READ command. For LPDDR4 READ-to-PRECHARGE timings see Table "Timing Between Commands (Precharge and Auto-Precharge)".

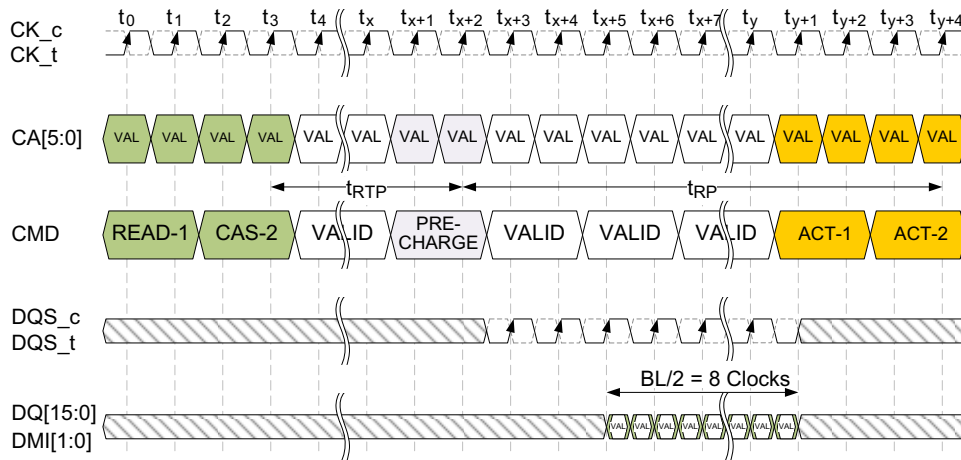

Figure 57 - Burst Read followed by Precharge (Shown with BL16, 2tCK pre-ample)

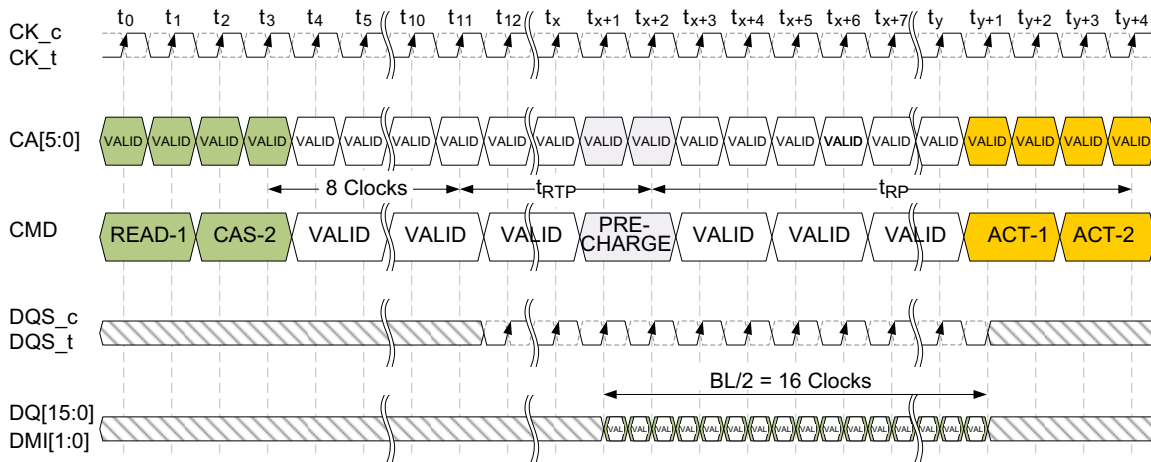

Figure 58 - Burst Read followed by Precharge (Shown with BL32, 2tCK Preamble)

2.18.2. Burst Write followed by Precharge

A Write Recovery time (t_{WR}) must be provided before a PRECHARGE command may be issued. This delay is referenced from the next rising edge of CK_t after the last latching DQS clock of the burst.

LPDDR4-SDRAM devices write data to the memory array in prefetch multiples (prefetch=16). An internal WRITE operation can only begin after a prefetch group has been clocked, so t_{WR} starts at the prefetch boundaries. The minimum WRITE-to-PRECHARGE time for commands to the same bank is $WL + BL/2 + 1 + RU(t_{WR}/t_{CK})$ clock cycles.

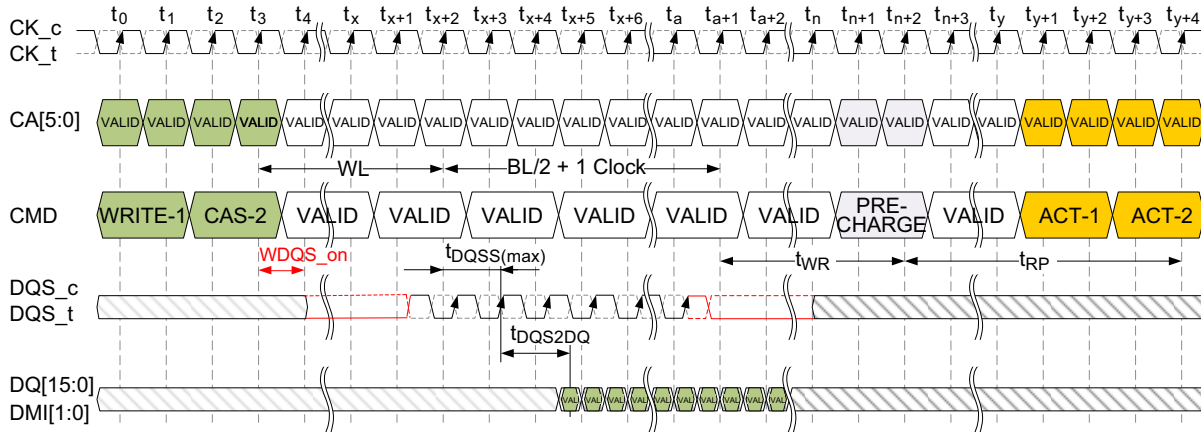

Figure 59 - Burst Write followed by Precharge (Shown with BL16, 2tCK preamble)

2.18.3. Auto Precharge operation

Before a new row can be opened in an active bank, the active bank must be precharged using either the PRECHARGE command or the Auto-Precharge function. When a READ, a WRITE or Masked Write command is issued to the device, the AP bit (CA5) can be set to enable the active bank to automatically begin precharge at the earliest possible moment during the burst READ, WRITE or Masked Write cycle.

If AP is LOW when the READ or WRITE command is issued, then the normal READ, WRITE or Masked Write burst operation is executed and the bank remains active at the completion of the burst.

If AP is HIGH when the READ, WRITE or Masked Write command is issued, the Auto-Precharge function is engaged. This feature enables the PRECHARGE operation to be partially or completely hidden during burst READ cycles (dependent upon READ or WRITE latency), thus improving system performance for random data access.

Read with Auto-Precharge or Write/Mask Write with Auto-Precharge commands may be issued after tRCD has been satisfied. The LPDDR4 SDRAM RAS Lockout feature will schedule the internal precharge to assure that tRAS is satisfied.

tRC needs to be satisfied prior to issuing subsequent Activate commands to the same bank.
Below Figure shows example of RAS lock function.

Figure 60 - Command Input Timing with RAS lock

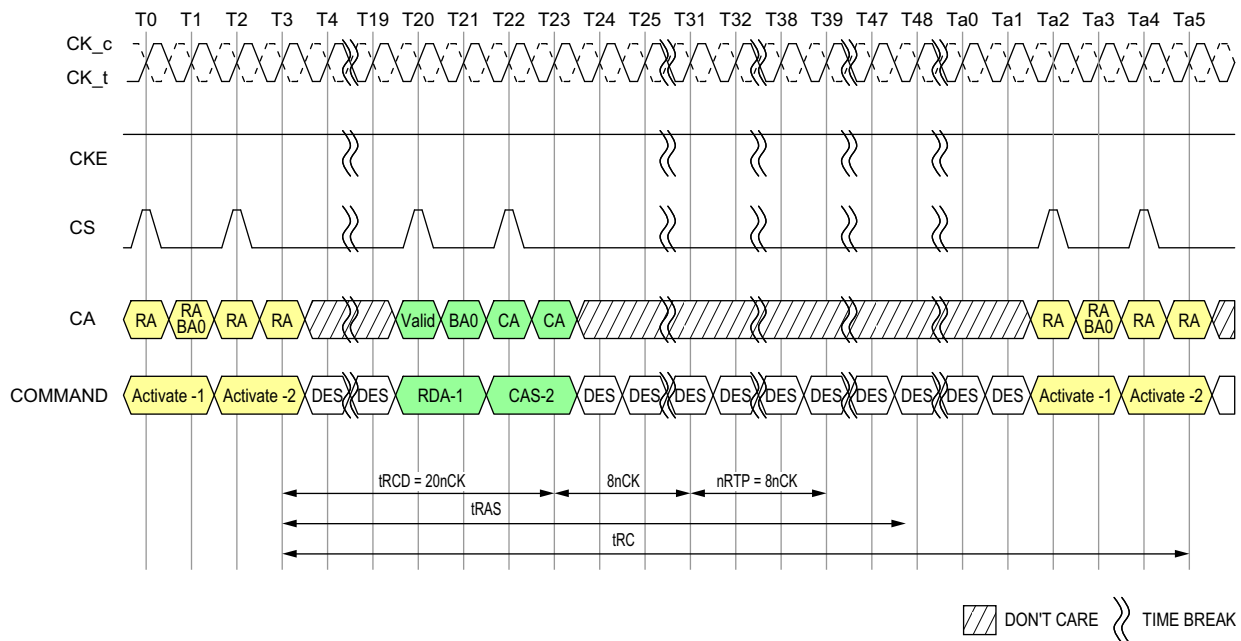

- NOTES : 1. tCK(AVG) = 0.938ns, Data Rate = 2133Mbps, tRCD(Min) = Max(18ns, 4nCK), tRAS(Min) = Max(42ns, 3nCK), nRTP = 8nCK, BL = 32
- 2. tRCD = 20nCK comes from Roundup(18ns/0.938ns)
- 3. DES commands are shown for ease of illustration; other commands may be valid at these times.

2.18.4. Burst Read with Auto-Precharge

If AP is HIGH when a READ command is issued, the READ with Auto-Precharge function is engaged. An internal precharge procedure starts a following delay time after the READ command. And this delay time depends on BL setting.

- BL = 16: nRTP
- BL = 32: 8nCK + nRTP

For LPDDR4 Auto-Precharge calculations, see Table 38. Following an Auto-Precharge operation, an ACTIVATE command can be issued to the same bank if the following two conditions are both satisfied:

- a. The RAS precharge time (tRP) has been satisfied from the clock at which the Auto-Precharge began, or
- b. The RAS cycle time (tRC) from the previous bank activation has been satisfied.

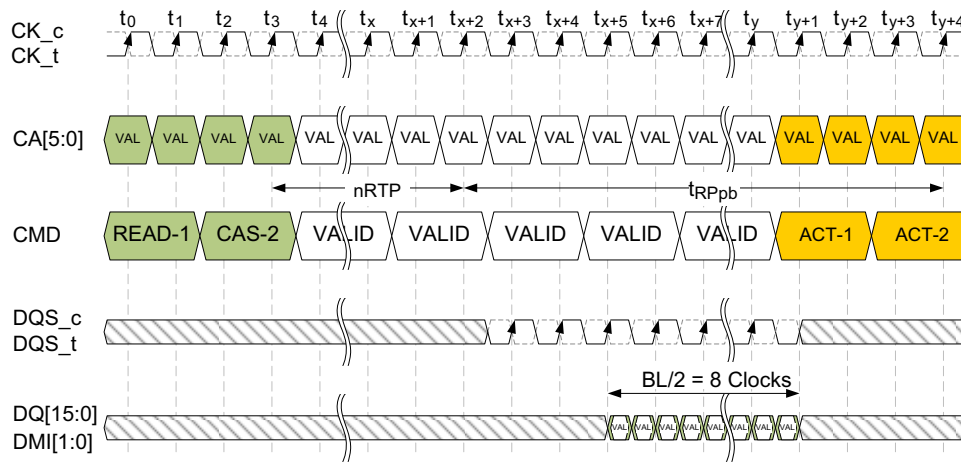

Figure 61 - Burst Read with Auto-Precharge (BL16, Toggling preamble)

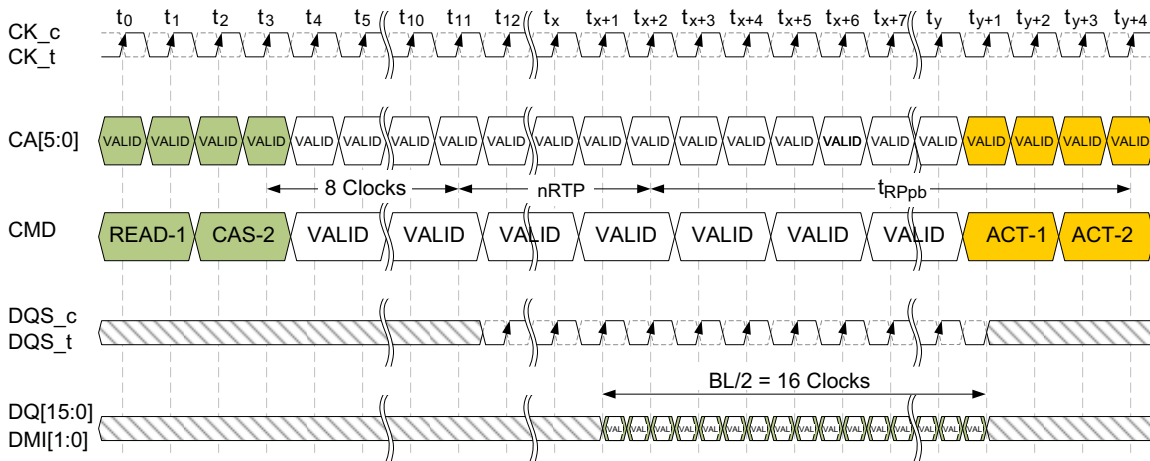

Figure 62 - Burst Read with Auto-Precharge (BL32, Toggling preamble)

2.18.5. Burst Write with Auto-Precharge

If AP is HIGH when a WRITE command is issued, the WRITE with Auto-Precharge function is engaged. The device starts an Auto-Precharge on the rising edge t_{WR} cycles after the completion of the Burst WRITE.

Following a WRITE with Auto-Precharge, an ACTIVATE command can be issued to the same bank if the following conditions are met:

- The RAS precharge time (t_{RP}) has been satisfied from the clock at which the Auto-Precharge began, and
- The RAS cycle time (t_{RC}) from the previous bank activation has been satisfied.

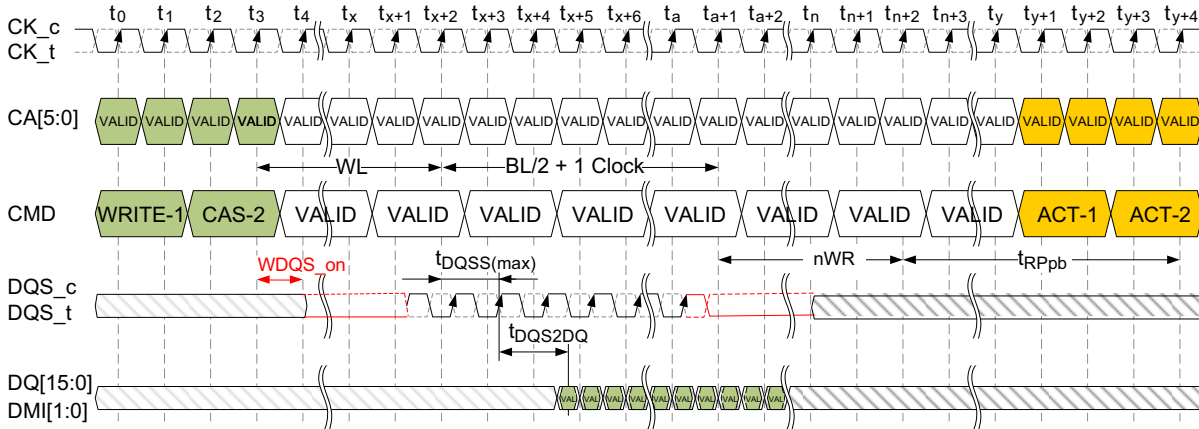

Figure 63 - Burst Write with Auto-Precharge (Shown with BL16, 2tCK preamble)

2.18.6. Delay Time from Write to Read with Auto Precharge

In the case of write command followed by read with Auto-Precharge, controller must satisfy tWR for the write command before initiating the DRAM internal Auto-Precharge. It means that (tWTR + nRTP) should be equal or longer than (tWR) when BL setting is 16, as well as (tWTR + nRTP + 8nCK) should be equal or longer than (tWR) when BL setting is 32. Refer to the following figure for details.

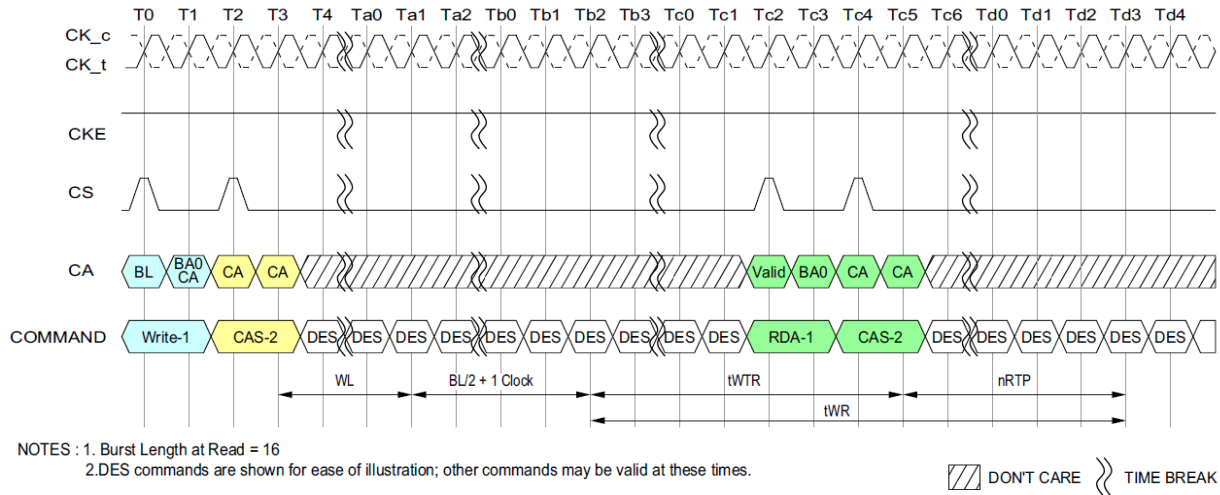

Figure 64 - Delay time from Write to Read with Auto-Precharge

Table 38 - Timing Between Commands (Precharge and Auto-Precharge) - DQ ODT is Disabled

From Command	To Command	Minimum Delay between "From Command" and "To Command"	Unit	Notes
Read (BL16)	Precharge (to same bank as Read)	tRTP	tCK	1,6
	Precharge All	tRTP	tCK	1,6
Read (BL32)	Precharge (to same bank as Read)	8*tCK + tRTP	tCK	1,6
	Precharge All	8*tCK + tRTP	tCK	1,6
Read w/ AP (BL16)	Precharge (to same bank as Read w/ AP)	nRTP	tCK	1,10
	Precharge All	nRTP	tCK	1,10
	Activate (to same bank as Read w/ AP)	nRTP + tRPpb	tCK	1,8,10
	Write or Write w/ AP (same bank)	Illegal	-	3
	Masked Write or Masked Write w/ AP (same bank)	Illegal	-	
	Write or Write w/ AP (different bank)	RL+RU(tDQSCK(max)/tCK)+BL/2+RD(trPST)-WL+tWPRE	tCK	3,4,5
Masked Write or Masked Write w/ AP (different bank)	RL+RU(tDQSCK(max)/tCK)+BL/2+RD(trPST)-WL+tWPRE	tCK	3,4,5	

From Command	To Command	Minimum Delay between "From Command" and "To Command"	Unit	Notes
Read w/ AP (BL16)	Read or Read w/ AP (same bank)	Illegal	-	
	Read or Read w/ AP (different bank)	BL/2	tCK	3
Read w/ AP (BL32)	Precharge (to same bank as Read w/ AP)	8*tCK + nRTP	tCK	1,10
	Precharge All	8*tCK + nRTP	tCK	1,10
	Activate (to same bank as Read w/ AP)	8*tCK + nRTP + tRPpb	tCK	1,8,10
	Write or Write w/ AP (same bank)	Illegal	-	
	Masked Write or Masked Write w/ AP (same bank)	Illegal	-	
	Write or Write w/ AP (different bank)	RL+RU(tDQSCK(max)/tCK)+BL/2+RD(trPST)-WL+tWPRE	tCK	3,4,5
	Masked Write or Masked Write w/ AP (different bank)	RL+RU(tDQSCK(max)/tCK)+BL/2+RD(trPST)-WL+tWPRE	tCK	3,4,5
	Read or Read w/ AP (same bank)	Illegal	-	
	Read or Read w/ AP (different bank)	BL/2	tCK	3
Write (BL16 & BL32)	Precharge (to same bank as Masked Write)	WL + BL/2 + tWR + 1	tCK	1,7
	Precharge All	WL + BL/2 + tWR + 1	tCK	1,7
Masked Write (BL16)	Precharge (to same bank as Masked Write)	WL + BL/2 + tWR + 1	tCK	1,7
	Precharge All	WL + BL/2 + tWR + 1	tCK	1,7
Write w/ AP (BL16 & BL32)	Precharge (to same bank as Write w/ AP)	WL + BL/2 + nWR + 1	tCK	1,11
	Precharge All	WL + BL/2 + nWR + 1	tCK	1,11
	Activate (to same bank as Write w/ AP)	WL + BL/2 + nWR + 1 + tRPpb	tCK	1,8,11
	Write or Write w/ AP (same bank)	Illegal	-	
	Write or Write w/ AP (different bank)	BL/2	tCK	3
	Masked-Write or Masked-Write w/ AP (different bank)	BL/2	tCK	3
	Read or Read w/ AP (same bank)	Illegal	-	
	Read or Read w/ AP (different bank)	WL + BL/2 + tWTR + 1	tCK	3,9

From Command	To Command	Minimum Delay between "From Command" and "To Command"	Unit	Notes
Masked Write w/ AP (BL16)	Precharge (to same bank as Masked Write w/ AP)	$WL + BL/2 + nWR + 1$	tCK	1,11
	Precharge all	$WL + BL/2 + nWR + 1$	tCK	1,11
	Activate (to same bank as Masked Write w/ AP)	$WL + BL/2 + nWR + 1 + tRPpb$	tCK	1,8,11
	Write or Write w/ AP (same bank)	Illegal	-	
	Masked Write or Masked Write w/ AP (same bank)	Illegal	-	
	Write or Write w/ AP (different bank)	BL/2	tCK	3
	Masked Write or Masked Write w/ AP (different bank)	BL/2	tCK	3
	Read or Read w/ AP (same bank)	Illegal	-	
	Read or Read w/ AP (different bank)	$WL + BL/2 + tWTR + 1$	tCK	3,9
Precharge	Precharge (to same bank as Precharge)	4	tCK	1
	Precharge All	4	tCK	1
Precharge All	Precharge	4	tCK	1
	Precharge All	4	tCK	1

Notes

- For a given bank, the precharge period should be counted from the latest precharge command, whether per-bank or all-bank, issued to that bank. The precharge period is satisfied tRP after that latest precharge command.
- Any command issued during the minimum delay time as specified in the table above is illegal.
- After READ w/AP, seamless read operations to different banks are supported. After WRITE w/AP or Masked Write w/AP, seamless write operations to different banks are supported. READ, WRITE, and Masked Write operations may not be truncated or interrupted.
- tRPST values depend on MR1 OP[7] respectively
- tWPRE values depend on MR1 OP[2] respectively
- Minimum Delay between "From Command" and "To Command" in clock cycle is calculated by dividing tRTP(in ns) by tCK(in ns) and rounding up to the next integer: $\text{Minimum Delay}[\text{cycles}] = \text{Roundup}(tRTP[\text{ns}] / tCK[\text{ns}])$
- Minimum Delay between "From Command" and "To Command" in clock cycle is calculated by dividing tWR(in ns) by tCK(in ns) and rounding up to the next integer: $\text{Minimum Delay}[\text{cycles}] = \text{Roundup}(tWR[\text{ns}] / tCK[\text{ns}])$
- Minimum Delay between "From Command" and "To Command" in clock cycle is calculated by dividing tRPpb(in ns) by tCK(in ns) and rounding up to the next integer: $\text{Minimum Delay}[\text{cycles}] = \text{Roundup}(tRPpb[\text{ns}] / tCK[\text{ns}])$
- Minimum Delay between "From Command" and "To Command" in clock cycle is calculated by dividing tWTR(in ns) by tCK(in ns) and rounding up to the next integer: $\text{Minimum Delay}[\text{cycles}] = \text{Roundup}(tWTR[\text{ns}] / tCK[\text{ns}])$
- For Read w/AP the value is nRTP which is defined in Mode Register 2.
- For Write w/AP the value is nWR which is defined in Mode Register 1.

Table 39 - Timing Between Commands (Precharge and Auto-Precharge) - DQ ODT is Enabled

From Command	To Command	Minimum Delay between "From Command" and "To Command"	Unit	Notes
Read w/ AP (BL16)	Write or Write w/ AP (different bank)	$RL+RU(tDQSCK(max)/tCK)+BL/2+RD(tRPST)-ODTLon-RD(tODTon,min/tCK)+1$	tCK	2,3
	Masked Write or Masked Write w/ AP (different bank)	$RL+RU(tDQSCK(max)/tCK)+BL/2+RD(tRPST)-ODTLon-RD(tODTon,min/tCK)+1$	tCK	2,3
Read w/ AP (BL32)	Write or Write w/ AP (different bank)	$RL+RU(tDQSCK(max)/tCK)+BL/2+RD(tRPST)-ODTLon-RD(tODTon,min/tCK)+1$	tCK	2,3
	Masked Write or Masked Write w/ AP (different bank)	$RL+RU(tDQSCK(max)/tCK)+BL/2+RD(tRPST)-ODTLon-RD(tODTon,min/tCK)+1$	tCK	2,3

Notes

1. The rest of Precharge and Auto-Precharge timings are as same as DQ ODT disabled case.
2. After READ w/AP, seamless read operations to different banks are supported. READ, WRITE, and Masked Write operations may not be truncated or interrupted.
3. tRPST values depend on MR1 OP[7] respectively.

2.19. Refresh command

The REFRESH command is initiated with CS HIGH, CA0 LOW, CA1 LOW, CA2 LOW, CA3 HIGH and CA4 LOW at the first rising edge of the clock. Per-bank REFRESH is initiated with CA5 LOW at the first rising edge of the clock. All-bank REFRESH is initiated with CA5 HIGH at the first rising edge of the clock.

A per-bank REFRESH command (REFpb) is performed to the bank address as transferred on CA0, CA1 and CA2 at the second rising edge of the clock. Bank address BA0 is transferred on CA0, bank address BA1 is transferred on CA1 and bank address BA2 is transferred on CA2. A per-bank REFRESH command (REFpb) to the eight banks can be issued in any order. e.g. REFpb commands are issued in the following order: 1-3-0-2-4-7-5-6. After the eight banks have been refreshed using the per-bank REFRESH command the controller can send another set of per-bank REFRESH commands in the same order or a different order. e.g. REFpb commands are issued in the following order that is different from the previous order: 7-1-3-5-0-4-2-6. One of the possible order can also be a sequential round robin: 0-1-2-3-4-5-6-7. It is illegal to send a per-bank REFRESH command to the same bank unless all eight banks have been refreshed using the per-bank REFRESH command. The count of eight REFpb commands starts with the first REFpb command after a synchronization event.

The bank count is synchronized between the controller and the SDRAM by resetting the bank count to zero. Synchronization can occur upon asserting RESET_n or at every exit from self refresh. REFab command also synchronizes the counter between the controller and SDRAM to zero. The SDRAM device can be placed in self-refresh or a REFab command can be issued at any time without cycling through all eight banks using per-bank REFRESH command. After the bank count is synchronized to zero the controller can issue per-bank REFRESH commands in any order as described in the previous paragraph.

A REFab command issued when the bank counter is not zero will reset the bank counter to zero and the DRAM will perform refreshes to all banks as indicated by the row counter. If another refresh command (REFab or REFpb) is issued after the REFab command then it uses an incremented value of the row counter.

The table below shows examples of both bank and refresh counter increment behavior.

Table 40 - Bank and Refresh counter increment behavior

#	Sub #	Command	BA0	BA1	BA2	Refresh Bank#	Bank Counter #	Ref Counter # (Row Address #)	
0	0	Reset, SRX or REFab						To 0	-
1	1	REFpb	0	0	0	0	0 to 1	n	
2	2	REFpb	0	0	1	1	1 to 2		
3	3	REFpb	0	1	0	2	2 to 3		
4	4	REFpb	0	1	1	3	3 to 4		
5	5	REFpb	1	0	0	4	4 to 5		
6	6	REFpb	1	0	1	5	5 to 6		
7	7	REFpb	1	1	0	6	6 to 7		
8	8	REFpb	1	1	1	7	7 to 0		
9	1	REFpb	1	1	0	6	0 to 1	n + 1	
10	2	REFpb	1	1	1	7	1 to 2		
11	3	REFpb	0	0	1	1	2 to 3		
12	4	REFpb	0	1	1	3	3 to 4		
13	5	REFpb	1	0	1	5	4 to 5		
14	6	REFpb	0	1	0	2	5 to 6		
15	7	REFpb	0	0	0	0	6 to 7		
16	8	REFpb	1	0	0	4	7 to 0		
17	1	REFpb	0	0	0	0	0 to 1	n + 2	
18	2	REFpb	0	0	1	1	1 to 2		
19	3	REFpb	0	1	0	2	2 to 3		
24	0	REFab	V	V	V	0~7	To 0	n + 2	
25	1	REFpb	1	1	0	6	0 to 1	n + 3	
26	2	REFpb	1	1	1	7	1 to 2		
Snip									

A bank must be idle before it can be refreshed. The controller must track the bank being refreshed by the per-bank REFRESH command.

The REFpb command must not be issued to the device until the following conditions are met:

- tRFCab has been satisfied after the prior REFab command
- tRFCpb has been satisfied after the prior REFpb command
- tRP has been satisfied after the prior PRECHARGE command to that bank
- tRRD has been satisfied after the prior ACTIVATE command (if applicable, for example after activating a row in a different bank than the one affected by the REFpb command).

The target bank is inaccessible during per-bank REFRESH cycle time (tRFCpb), however, other banks within the device are accessible and can be addressed during the cycle. During the REFpb operation, any of the banks other than the one being refreshed can be maintained in an active state or accessed by a READ or a WRITE command. When the per-bank REFRESH cycle has completed, the affected bank will be in the idle state.

After issuing REFpb, these conditions must be met:

- tRFCpb must be satisfied before issuing a REFab command
- tRFCpb must be satisfied before issuing an ACTIVATE command to the same bank
- tRRD must be satisfied before issuing an ACTIVATE command to a different bank
- tRFCpb must be satisfied before issuing another REFpb command.

An all-bank REFRESH command (REFab) issues a REFRESH command to all banks. All banks must be idle when REFab is issued (for instance, by issuing a PRECHARGE-all command prior to issuing an all-bank REFRESH command). REFab also synchronizes the bank count between the controller and the SDRAM to zero. The REFab command must not be issued to the device until the following conditions have been met:

- tRFCab has been satisfied following the prior REFab command
- tRFCpb has been satisfied following the prior REFpb command
- tRP has been satisfied following the prior PRECHARGE commands.

When an all-bank refresh cycle has completed, all banks will be idle. After issuing REFab:

- tRFCab latency must be satisfied before issuing an ACTIVATE command
- tRFCab latency must be satisfied before issuing a REFab or REFpb command.

Table 41 - REFRESH Command Scheduling Separation requirements

Symbol	minimum delay from	to	Notes
tRFCab	REFab	REFab	
		Activate command to any bank	
		REFpb	
tRFCpb	REFpb	REFab	
		Activate command to same bank as REFpb	
		REFpb	
tRRD	REFpb	Activate command to different bank than REFpb	
	Activate	REFpb	1
		Activate command to different bank than prior Activate command	

Notes

1. A bank must be in the idle state before it is refreshed, so following an ACTIVATE command REFab is prohibited; REFpb is supported only if it affects a bank that is in the idle state.

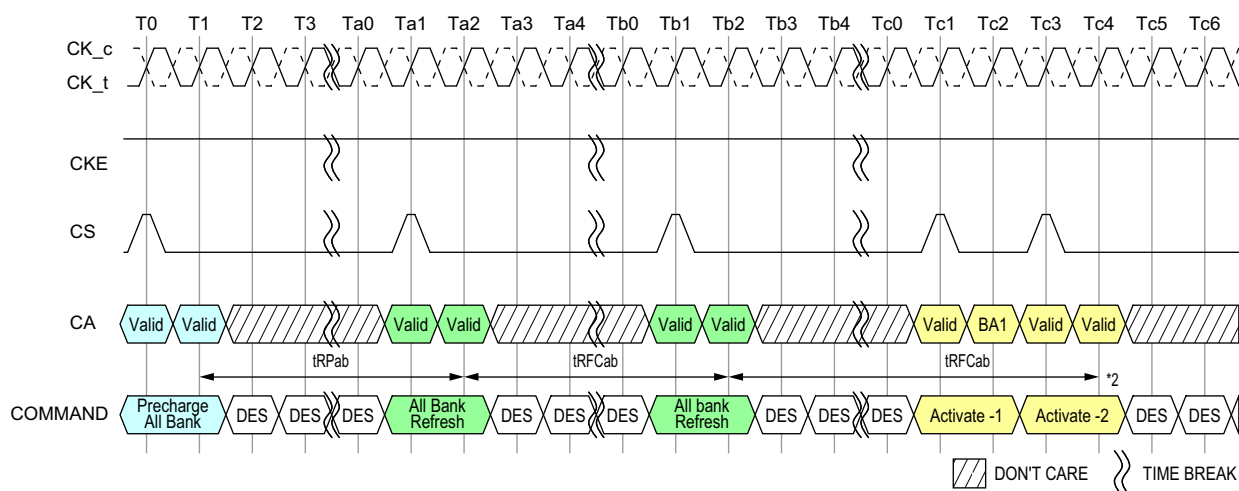

- NOTES : 1. DES commands are shown for ease of illustration; other commands may be valid at these times.
 2. Activate Command is shown as an example. Other commands may be valid provided the timing specification is satisfied.

Figure 65 - All-Bank REFRESH Operation

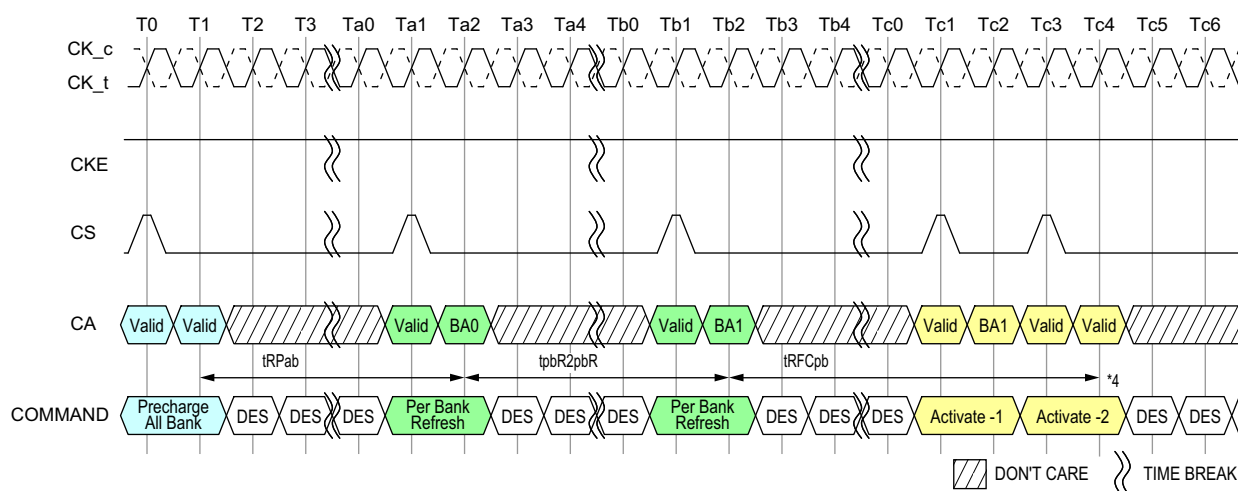

- NOTES : 1. DES commands are shown for ease of illustration; other commands may be valid at these times.
 2. In the beginning of this example, the REFpb bank is pointing to bank 0.
 3. Operations to banks other than the bank being refreshed are supported during the tpbR2pbR period.
 4. Activate Command is shown as an example. Other commands may be valid provided the timing specification is satisfied.

Figure 66 - Per Bank Refresh to a different bank Operation

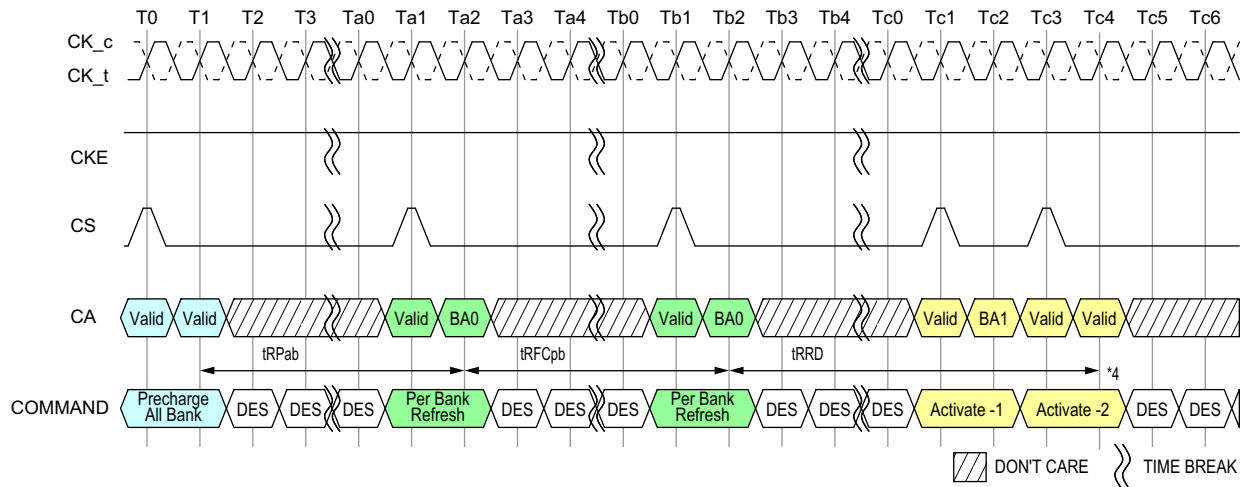

- NOTES :
1. DES commands are shown for ease of illustration; other commands may be valid at these times.
 2. In the beginning of this example, the REFpb bank is pointing to bank 0.
 3. Operations to banks other than the bank being refreshed are supported during the tRFCpb period.
 4. Activate Command is shown as an example. Other commands may be valid provided the timing specification is satisfied.

Figure 67 - Per Bank Refresh to the same bank Operation

In general, a Refresh command needs to be issued to the LPDDR4 SDRAM regularly every tREFI interval. To allow for improved efficiency in scheduling and switching between tasks, some flexibility in the absolute refresh interval is provided. A maximum of 8 Refresh commands can be postponed during operation of the LPDDR4 SDRAM, meaning that at no point in time more than a total of 8 Refresh commands are allowed to be postponed and maximum number of pulled-in or postponed REF command is dependent on refresh rate. It is described in the table below. In case that 8 Refresh commands are postponed in a row, the resulting maximum interval between the surrounding Refresh commands is limited to $9 \times tREFI$. A maximum of 8 additional Refresh commands can be issued in advance ("pulled in"), with each one reducing the number of regular Refresh commands required later by one. Note that pulling in more than 8 Refresh commands in advance does not further reduce the number of regular Refresh commands required later, so that the resulting maximum interval between two surrounding Refresh commands is limited to $9 \times tREFI$.

At any given time, a maximum of 16 REF commands can be issued within 2 x tREFI. Self-Refresh Mode may be entered with a maximum of eight Refresh commands being postponed. After exiting Self-Refresh Mode with one or more Refresh commands postponed, additional Refresh commands may be postponed to the extent that the total number of postponed Refresh commands (before and after the Self-Refresh) will never exceed eight. During Self-Refresh Mode, the number of postponed or pulled-in REF commands does not change.

And for per bank refresh, a maximum 8 x 8 per bank refresh commands can be postponed or pulled in for scheduling efficiency. At any given time, a maximum of 2 x 8 x 8 per bank refresh commands can be issued within 2 x tREFI.

Table 42 - Legacy Refresh Command Timing Constraints

MR4 OP[2:0]	Refresh rate	Max. No. of pulled in or postponed REFab	Max. interval between two REFab	Max. No. of REFab within max(2*tREFI*Refresh rate multiplier, 16*tRFC)	Per-bank Refresh
000B	Low Temp. Limit	N/A	N/A	N/A	N/A
001B	4 x tREFI	8	9 x 4 x tREFI	16	1/8 of REFab
010B	2 x tREFI	8	9 x 2 x tREFI	16	1/8 of REFab
011B	1 x tREFI	8	9 x tREFI	16	1/8 of REFab
100B	0.5 x tREFI	8	9 x 0.5 x tREFI	16	1/8 of REFab
101B	0.25 x tREFI	8	9 x 0.25 x tREFI	16	1/8 of REFab
110B	0.25 x tREFI	8	9 x 0.25 x tREFI	16	1/8 of REFab
111B	High Temp. Limit	N/A	N/A	N/A	N/A

Table 43 - Modified Refresh Command Timing Constraints

MR4 OP[2:0]	Refresh rate	Max. No. of pulled in or postponed REFab	Max. interval between two REFab	Max. No. of REFab within max(2*tREFI*Refresh rate multiplier, 16*tRFC)	Per-bank Refresh
000B	Low Temp. Limit	N/A	N/A	N/A	N/A
001B	4 x tREFI	2	3 x 4 x tREFI	4	1/8 of REFab
010B	2 x tREFI	4	5 x 2 x tREFI	8	1/8 of REFab
011B	1 x tREFI	8	9 x tREFI	16	1/8 of REFab
100B	0.5 x tREFI	8	9 x 0.5 x tREFI	16	1/8 of REFab
101B	0.25 x tREFI	8	9 x 0.25 x tREFI	16	1/8 of REFab
110B	0.25 x tREFI	8	9 x 0.25 x tREFI	16	1/8 of REFab
111B	High Temp. Limit	N/A	N/A	N/A	N/A

Notes

- For any thermal transition phase where Refresh mode is transitioned to either 2x tREFI or 4x tREFI, DRAM will support the previous postponed refresh requirement provided the number of postponed refreshes is monotonically reduced to meet the new requirement. However, the pulled-in refresh commands in previous thermal phase are not applied in new thermal phase. Entering new thermal phase the controller must count the number of pulled-in refresh commands as zero, regardless of remaining pulled-in refresh commands in previous thermal phase.
- LPDDR4 devices are refreshed properly if memory controller issues refresh commands with same or shorter refresh period than reported by MR4 OP[2:0]. If shorter refresh period is applied, the corresponding requirements from Table apply. For example, when MR4 OP[2:0]=001B, controller can be in any refresh rate from 4xtREFI to 0.25x tREFI. When MR4 OP[2:0]=010B, the only prohibited refresh rate is 4x tREFI.

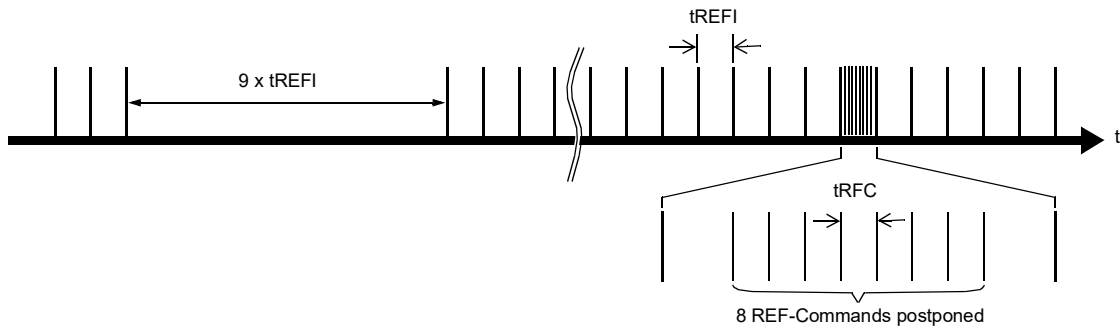

Figure 68 - Postponing Refresh Commands (Example)

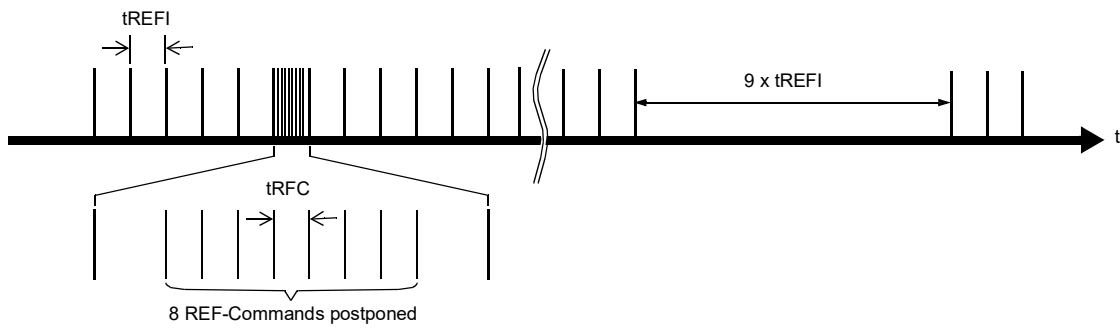
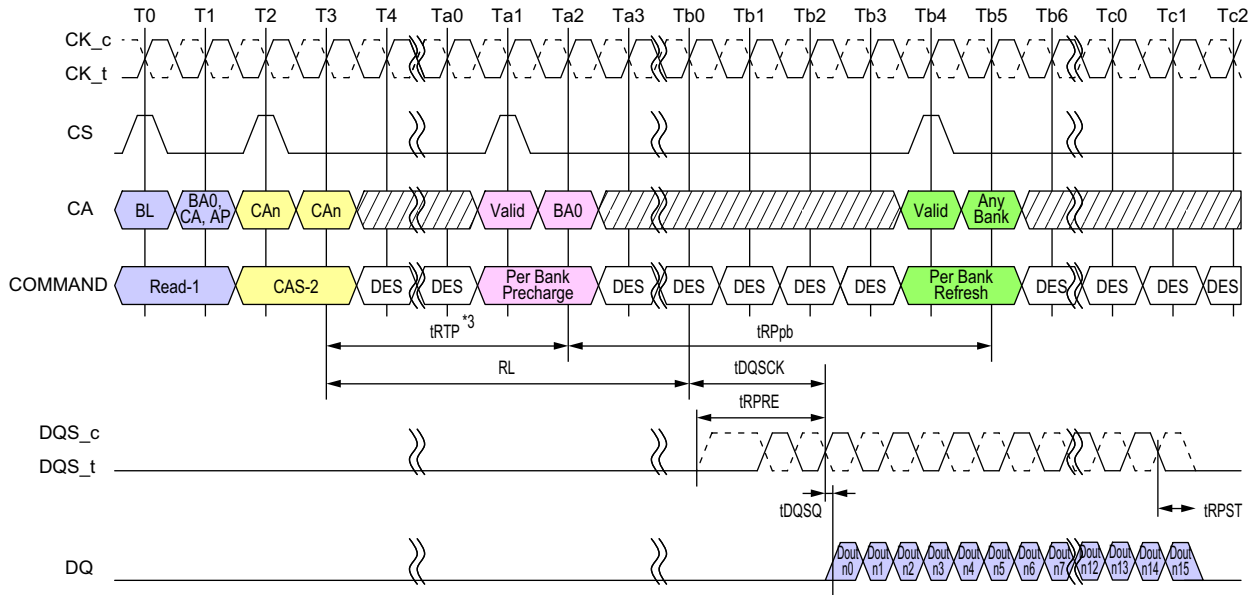

Figure 69 - Pulling-in Refresh Commands (Example)

2.19.1. Burst Read operation followed by Per Bank Refresh

The Per Bank Refresh command can be issued after $t_{RTP} + t_{RPpb}$ from Read command.



- Note
1. BL = 16, Preamble = Toggle, Postamble = $0.5nCK$, DQ/DQS: VSSQ termination
 2. Dout n = data-out from column n.
 3. In case of BL = 32, Delay time from Read to Per Bank Precharge is $8nCK + t_{RTP}$.
 4. DES commands are shown for ease of illustration; other commands may be valid at these times.

Figure 70 - Burst Read operation followed by Per Bank Refresh

The Per Bank Refresh command can be issued after t_{RC} from Read with Auto Precharge command.

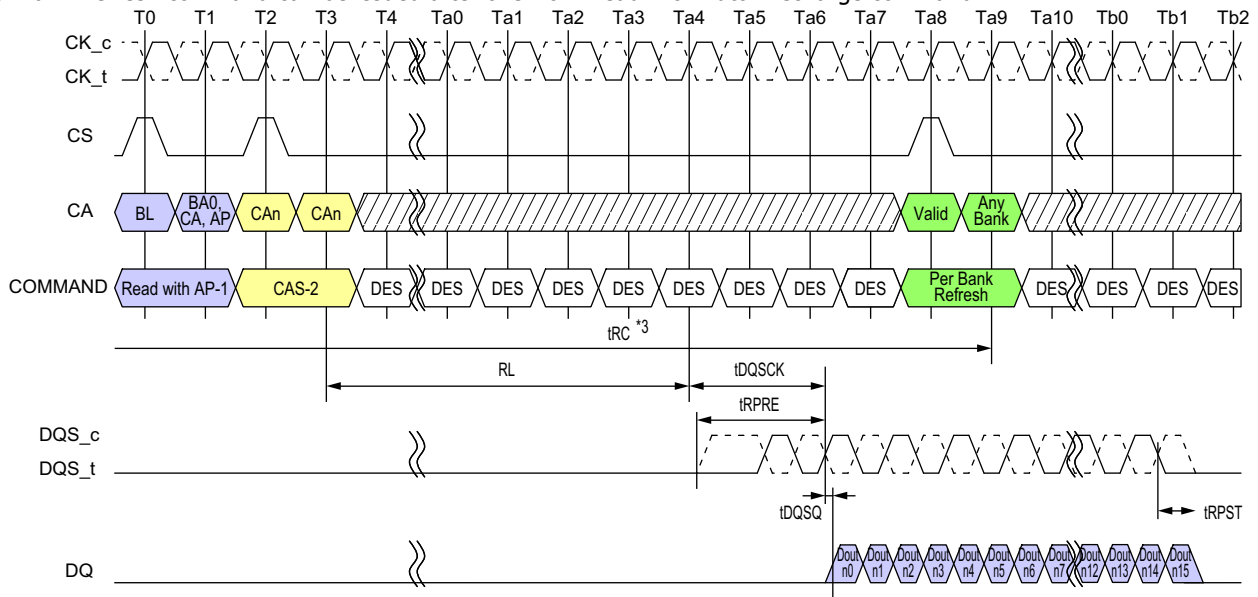

- Note
1. BL = 16, Preamble = Toggle, Postamble = $0.5nCK$, DQ/DQS: VSSQ termination
 2. Dout n = data-out from column n.
 3. t_{RC} needs to be satisfied prior to issuing subsequent Per Bank Refresh command.
 4. DES commands are shown for ease of illustration; other commands may be valid at these times.

Figure 71 - Burst Read with Auto-Precharge operation followed by Per Bank Refresh

2.20. Refresh Requirements

Between SRX command and SRE command, at least one extra refresh command is required. After the DRAM Self Refresh Exit command, in addition to the normal Refresh command at tREFI interval, the LPDDR4 DRAM requires minimum of one extra Refresh command prior to Self Refresh Entry command.

Table 44 - Refresh Requirement Parameters per die

Refresh Requirements		Symbol	1Gb	2Gb	3Gb	4Gb	6Gb	8Gb	12Gb	16Gb	Units
Density per Channel			1Gb	2Gb	3Gb	4Gb	6Gb	8Gb	12Gb	16Gb	
Number of banks per channel			8								
Refresh Window (tREFW) (1x Refresh) ^{1,2}		tREFW	32								
Required Number of REFRESH Commands in a tREFW window		R	8192								-
Average Refresh Interval (1x Refresh) ¹	REFAB	tREFI	3.904								us
	REFPB	tREFIpb	488								ns
Refresh Cycle Time (All Banks)		tRFCab	130	130	180	180	280	380		ns	
Refresh Cycle Time (Per Bank)		tRFCpb	60	60	90	90	140	190		ns	
Per-bank Refresh to Per-bank Refresh different bank Time		tpbR2pbR	60		90					ns	

Notes:

- 1x refresh rate (tREFW=32ms) is supported at all temperatures at or below 85°C Tcase. If MR4 OP[2:0] indicates a refresh rate of greater than 1x is supported, tREFW can be extended.
2. Refer to MR4 OP[2:0] for detailed Refresh Rate and its multipliers.

2.21. Self Refresh Operation

2.21.1. Self Refresh Entry and Exit

The Self Refresh command can be used to retain data in the LPDDR4 SDRAM, the SDRAM retains data without external Refresh command. The device has a built-in timer to accommodate Self Refresh operation. The Self Refresh is entered by Self Refresh Entry Command defined by having CS High, CA0 Low, CA1 Low, CA2 Low; CA3 High; CA4 High, CA5 Valid (Valid that means it is Logic Level, High or Low) for the first rising edge and CS Low, CA0 Valid, CA1 Valid, CA2 Valid, CA3 Valid, CA4 Valid, CA5 Valid at the second rising edge of the clock. Self Refresh command is only allowed when read data burst is completed and SDRAM is idle state.

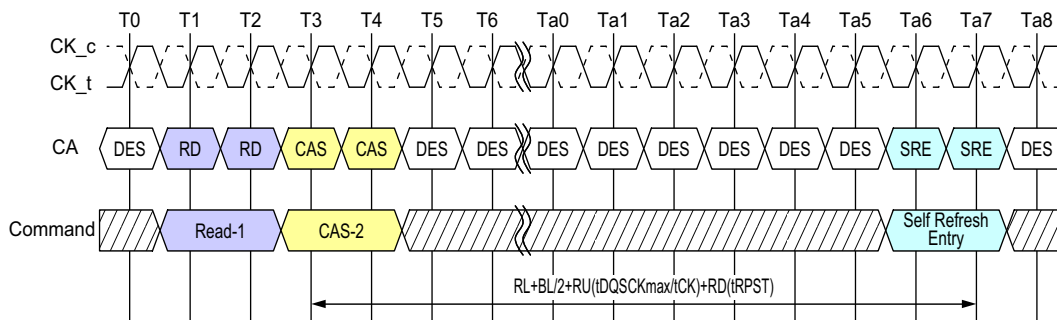

During Self Refresh mode, external clock input is needed and all input pin of SDRAM are activated. SDRAM can accept the following commands, MRR-1, CAS-2, DES, SRX, MPC, MRW-1, and MRW-2 except PASR Bank/Segment and SR Abort setting.

LPDDR4 SDRAM can operate in Self Refresh in both the standard or elevated temperature ranges. SDRAM will also manage Self Refresh power consumption when the operating temperature changes, lower at low temperature and higher at high temperatures.

For proper Self Refresh operation, power supply pins (VDD1, VDD2 and VDDQ) must be at valid levels. However VDDQ may be turned off during Self Refresh with Power Down after $t_{CKELCK}(\text{Max}(5\text{ns}, 5n\text{CK}))$ is satisfied (Refer to Figure 73 about t_{CKELCK}).

Prior to exiting Self Refresh with Power Down, VDDQ must be within specified limits. The minimum time that the SDRAM must remain in Self Refresh model is $t_{SR, \text{min}}$. Once Self Refresh Exit is registered, only MRR-1, CAS-2, DES, MPC, MRW-1 and MRW-2 except PASR Bank/Segment and SR Abort setting are allowed until t_{XSR} is satisfied.

The use of Self Refresh mode introduces the possibility that an internally timed refresh event can be missed when Self Refresh Exit is registered. Upon exit from Self Refresh, it is required that at least one REFRESH command (8 per bank or 1 all bank) is issued before entry into a subsequent Self Refresh.

This REFRESH command is not included in the count of regular refresh commands required by the t_{REFI} interval, and does not modify the postponed or pulled-in refresh counts; the REFRESH command does count toward the maximum refreshes permitted within $2 \times t_{REFI}$.

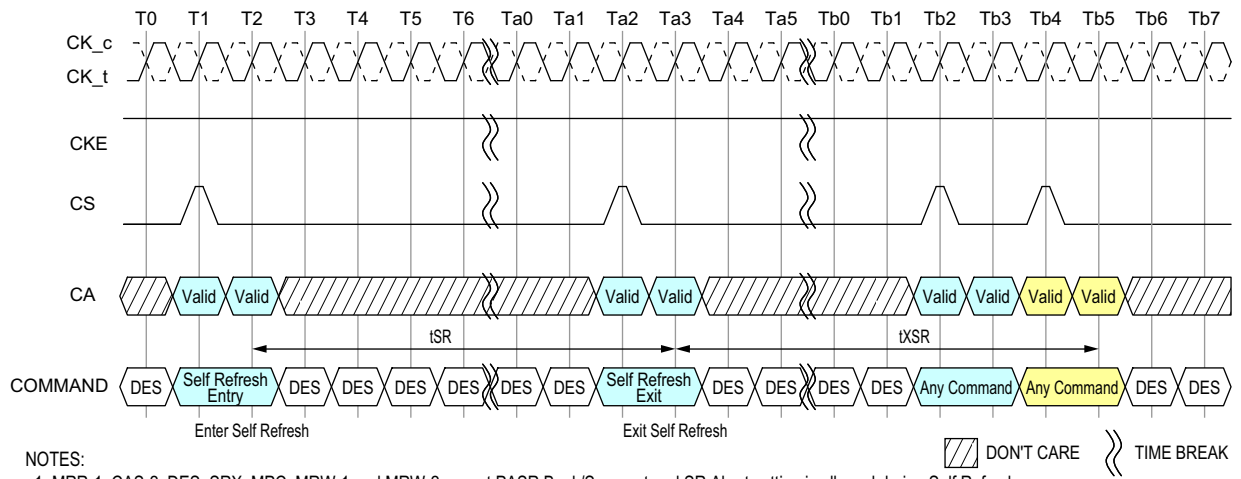
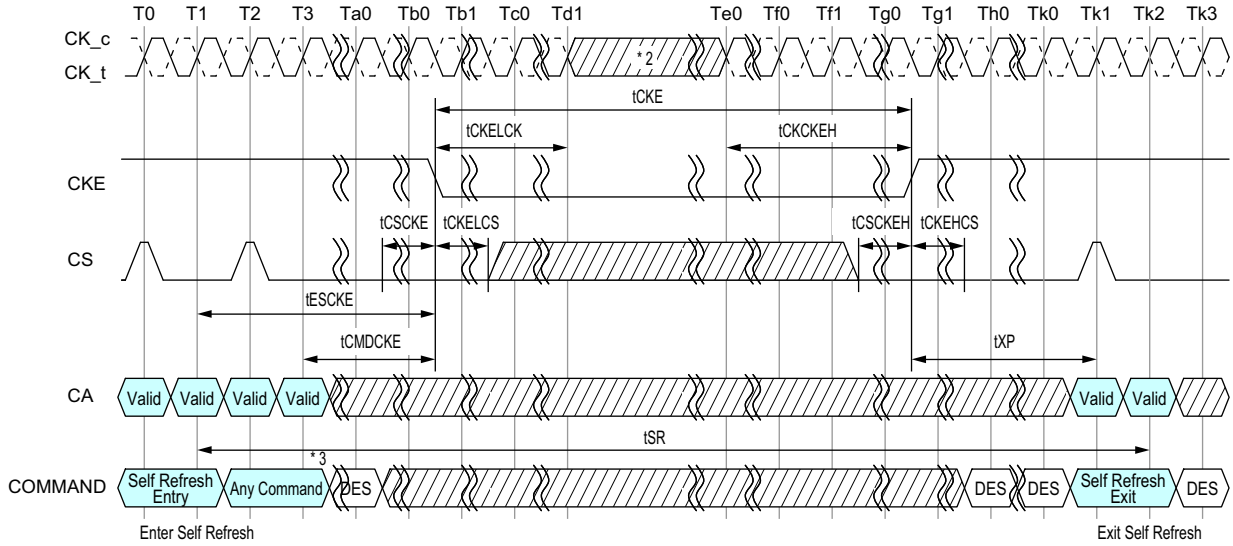

Figure 72 - Self Refresh Entry/Exit Timing

2.21.2. Power Down Entry and Exit during Self Refresh

Entering/Exiting Power Down Mode is allowed during Self Refresh mode in LPDDR4 SDRAM. The related timing parameters between Self Refresh Entry/Exit and Power Down Entry/Exit are shown in Figure-Self Refresh Entry/Exit Timing with Power Down Entry/Exit.



NOTES:

1. MRR-1, CAS-2, DES, SRX, MPC, MRW-1 and MRW-2 except PASR Bank/Segment setting is allowed during Self Refresh.
2. Input clock frequency can be changed or the input clock can be stopped or floated after tCKELCK satisfied and during power-down, provided that upon exiting power-down, the clock is stable and within specified limits for a minimum of tCKCKEH of stable clock prior to power-down exit and the clock frequency is between the minimum and maximum specified frequency for the speed grade in use.
3. 2 Clock command for example.

 DONT CARE  TIME BREAK

Figure 73 - Self Refresh Entry/Exit Timing with Power Down Entry/Exit

2.21.2.1. Partial Array Self-Refresh (PASR)

2.21.2.1.1. PASR Bank Masking

The LPDDR4 SDRAM has eight banks. Each bank of an LPDDR4 SDRAM can be independently configured whether a self refresh operation is taking place. One mode register unit of 8 bits, accessible via MRW command, is assigned to program the bank masking status of each bank up to 8 banks. For bank masking bit assignments, see Mode Register 16.

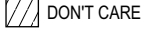
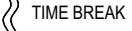
The mask bit to the bank controls a refresh operation of entire memory within the bank. If a bank is masked via MRW, a refresh operation to the entire bank is blocked and data retention by a bank is not guaranteed in self refresh mode. To enable a refresh operation to a bank, a coupled mask bit has to be programmed, "unmasked". When a bank mask bit is unmasked, a refresh to a bank is determined by the programmed status of segment mask bits, which is described in the following chapter.

2.21.2.1.2. PASR Segment Masking

A segment masking scheme may be used in lieu of or in combination with the bank masking scheme in LPDDR4 SDRAM which utilize eight segments per bank. For segment masking bit assignments, see Mode Register 17. For those refresh-enabled banks, a refresh operation to the address range which is represented by a segment is blocked when the mask bit to this segment is programmed, "masked". Programming of segment mask bits is similar to the one of bank mask bits. Eight segments are used as listed in Mode Register 17. One mode register unit is used for the programming of segment mask bits up to 8 bits. One more mode register unit may be reserved for future use. Programming of bits in the reserved registers has no effect on the device operation.

Table 45 - Example of Bank and Segment Masking use in LPDDR4 SDRAM

	Segment Mask (MR17)	Bank 0	Bank 1	Bank 2	Bank 3	Bank 4	Bank 5	Bank 6	Bank 7
Bank Mask (MR16)		0	1	0	0	0	0	0	1
Segment 0	0		M						M
Segment 1	0		M						M
Segment 2	1	M	M	M	M	M	M	M	M
Segment 3	0		M						M
Segment 4	0		M						M
Segment 5	0		M						M
Segment 6	0		M						M
Segment 7	1	M	M	M	M	M	M	M	M

Notes

1. This table illustrates an example of an 8-bank LPDDR4 SDRAM, when a refresh operation to bank 1 and bank 7, as well as segment 2 and segment 7 are masked.

2.21.3. Command Input Timing after Power Down Exit

Command input timings after Power Down Exit during Self Refresh mode are shown in Figure below.

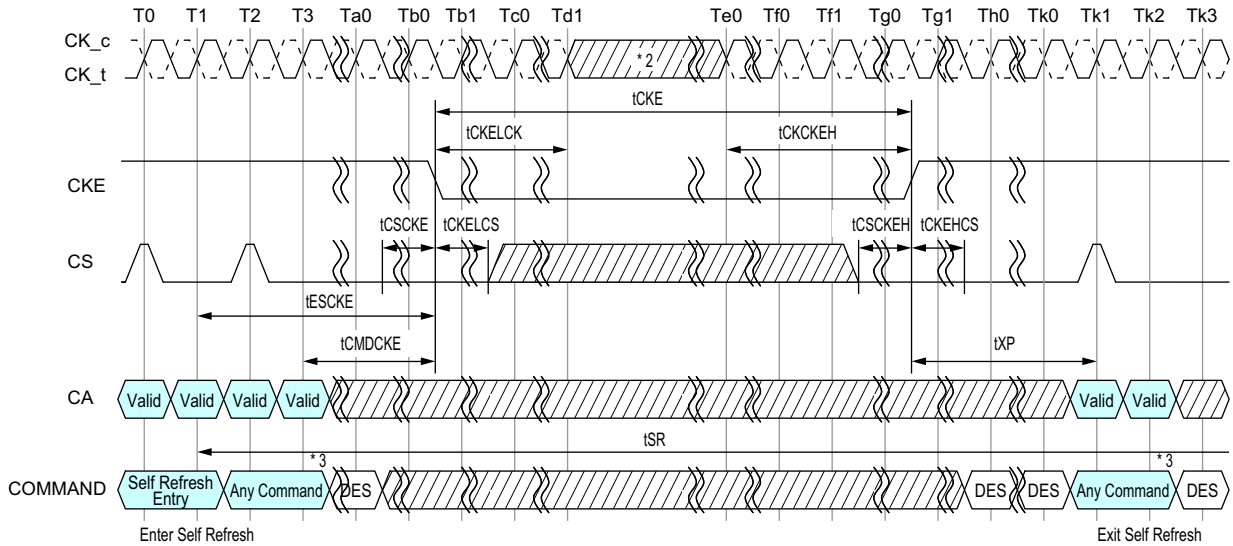

- NOTES:
- MRR-1, CAS-2, DES, SRX, MPC, MRW-1 and MRW-2 except PASR Bank/Segment setting is allowed during Self Refresh.
 - Input clock frequency can be changed or the input clock can be stopped or floated after tCKELCK satisfied and during power-down, provided that upon exiting power-down, the clock is stable and within specified limits for a minimum of tCKCKEH of stable clock prior to power-down exit and the clock frequency is between the minimum and maximum specified frequency for the speed grade in use.
 - 2 Clock command for example.

Figure 74 - Command input timings after Power Down Exit during Self Refresh

2.21.4. AC Timing Table

Table 46 - Self Refresh Timing Parameters

Parameter	Symbol	min max	533	1066	1600	2133	2667	3200	3733	4266	Unit	Note
Delay from SRE command to CKE Input low	tESCKE	min	max (1.75ns, 3tCK)								tCK	1
Minimum Self Refresh Time	tSR	min	max (15ns, 3nCK)								tCK	1
Exit Self Refresh to Valid commands	tXSR	min	max (tRFCab + 7.5ns, 2nCK)								tCK	1,2

Notes

1. Delay time has to satisfy both analog time(ns) and clock count(tCK). It means that tESCKE will not expire until CK has toggled through at least 3 full cycles (3 *tCK) and 1.75ns has transpired. The case which 3tCK is applied to is shown below.

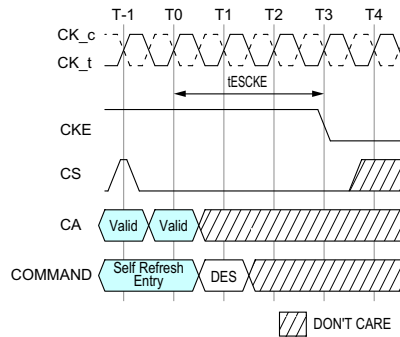

Figure 75 - tESCKE Timing

2. MRR-1, CAS-2, SRX, MPC, MRW-1, and MRW-2 commands (except PASR bank/segment setting) are only allowed during this period.

2.22. Self Refresh Abort

If MR4 OP[3] is enabled then DRAM aborts any ongoing refresh during Self Refresh exit and does not increment the internal refresh counter. Controller can issue a valid command after a delay of tXSR_abort instead of tXSR.

The value of tXSR_abort(min) is defined as tRFCpb + 17.5ns.

Upon exit from Self Refresh mode, the LPDDR4 SDRAM requires a minimum of one extra refresh (8 per bank or 1 all bank) before entry into a subsequent Self Refresh mode. This requirement remains the same irrespective of the setting of the MR bit for Self Refresh abort.

Self Refresh abort feature is available for higher density devices starting with 6 Gb single channel device.

2.23. MRR, MRW, MPC Command during tXSR, tRFC

Mode Register Read (MRR), Mode Register Write (MRW) and Multi Purpose Command (MPC) can be issued during tXSR period.

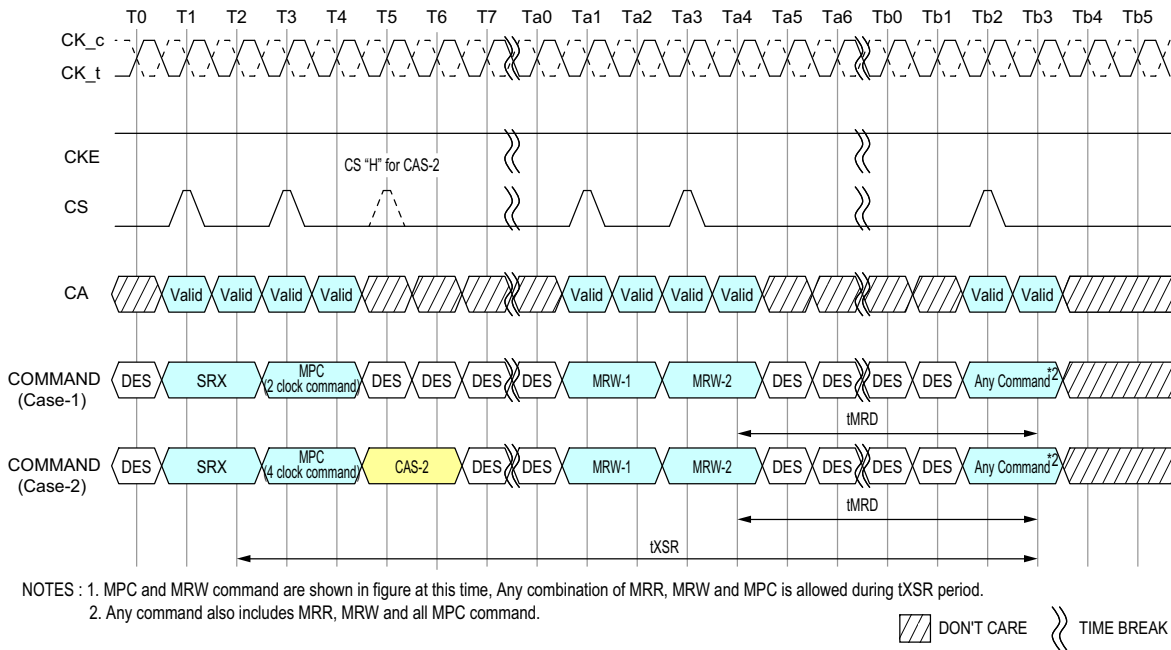

Figure 76 - MRR, MRW and MPC Commands Issuing Timing during tXSR

Mode Register Read (MRR), Mode Register Write (MRW) and Multi Purpose Command (MPC) can be issued during tRFC period.

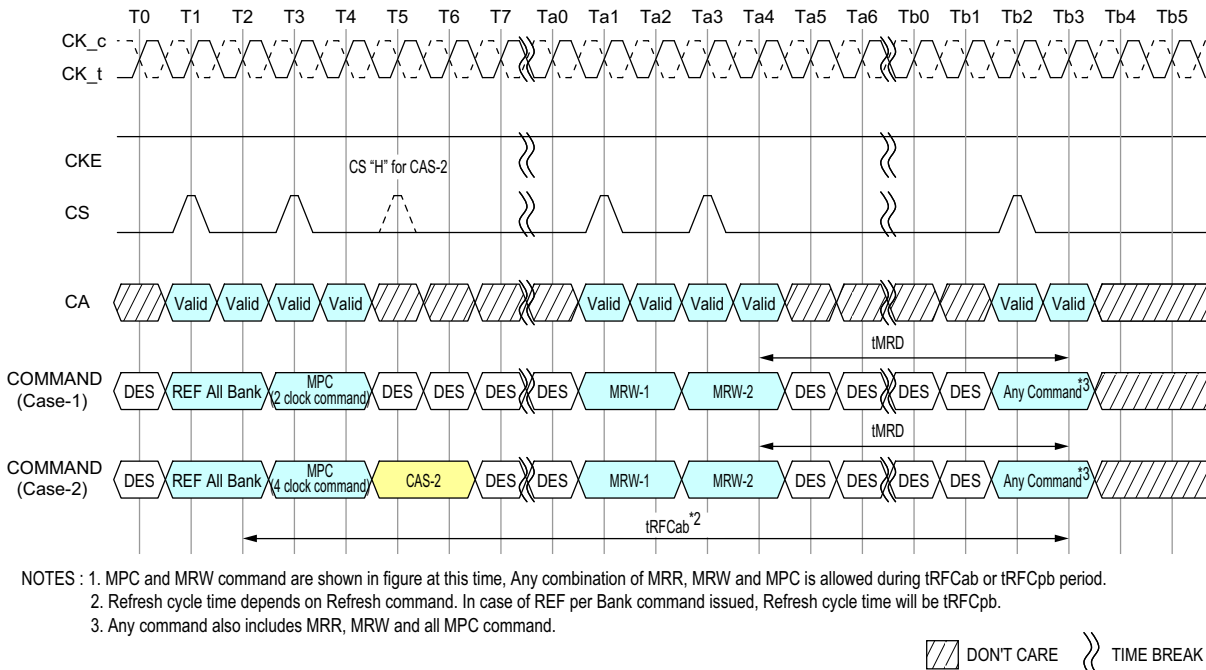

Figure 77 - MRR, MRW and MPC Commands Issuing Timing during tRFC

2.24. Mode Register Read (MRR) command

The Mode Register Read (MRR) command is used to read configuration and status data from the LPDDR4-SDRAM registers. The MRR command is initiated with CS and CA[5:0] in the proper state as defined by the Command Truth Table. The mode register address operands (MA[5:0]) allow the user to select one of 64 registers. The mode register contents are available on the first 4UI's data bits of DQ[7:0] after $RL \times tCK + tDQSCK + tDQSQ$ following the MRR command. Subsequent data bits contain valid but undefined content. DQS is toggled for the duration of the Mode Register READ burst. The MRR has a command burst length 16.

MRR operation must not be interrupted.

Table 47 - DQ output mapping

BL	0	1	2	3	4	5	6	7	8	9	10	11	12	13	14	15
DQ0	OP0				V											
DQ1	OP1				V											
DQ2	OP2				V											
DQ3	OP3				V											
DQ4	OP4				V											
DQ5	OP5				V											
DQ6	OP6				V											
DQ7	OP7				V											
DQ8-15	V								V							
DMI	V								V							

Notes

- MRR data are extended to first 4 UI's for DRAM controller to sample data easily.
- DBI may apply or may not apply during normal MRR. It's vendor specific. If read DBI is enable with MRS and vendor cannot support the DBI during MRR, DMI pin status should be low.
- The read pre-amble and post-amble of MRR are same as normal read.

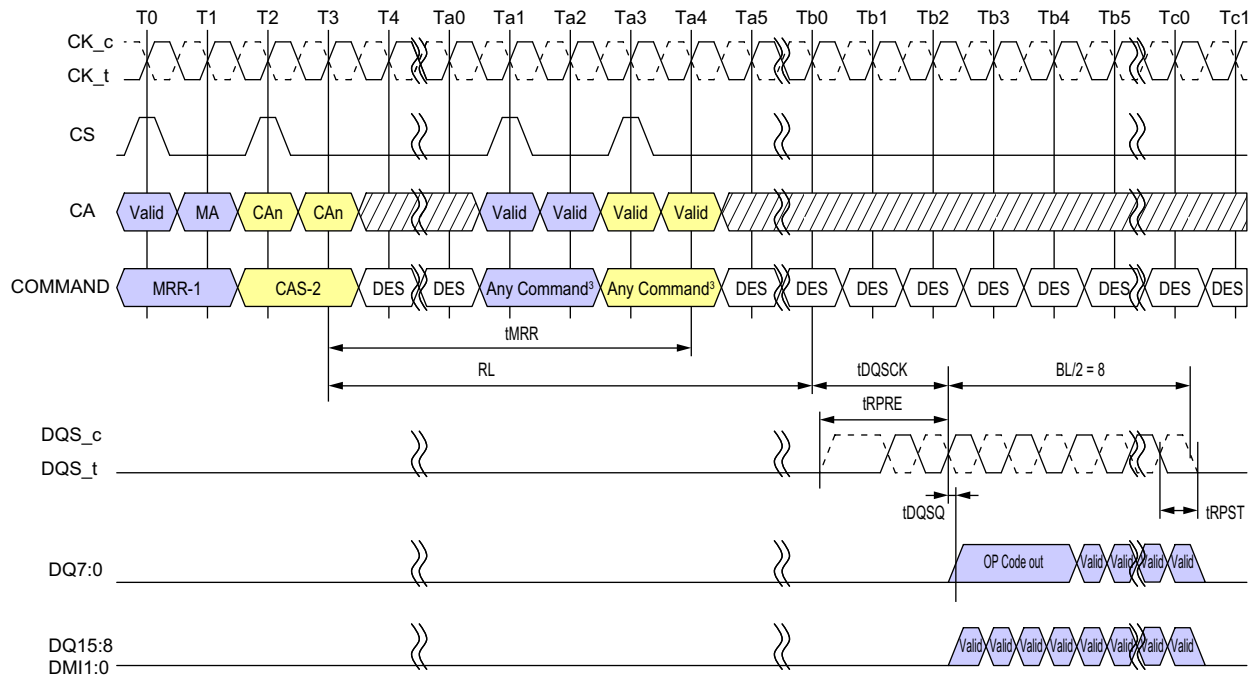

Note

1. Only BL=16 is supported
2. Only DES is allowed during tMRR period
3. There are some exceptions about issuing commands after tMRR. Refer to MRR/MRW Timing Constraints Table for detail.
4. DBI is Disable mode.
5. DES commands except tMRR period are shown for ease of illustration; other commands may be valid at these times.
6. DQ/DQS: VSSQ termination



 DON'T CARE  TIME BREAK

Figure 78 - Mode Register Read Operation

2.24.1. MRR After Read and Write Command

After a prior READ command, the MRR command must not be issued earlier than $BL/2$ clock cycles, in a similar way $WL + BL/2 + 1 + RU(tWTR/tCK)$ clock cycles after a prior Write, Write with AP, Mask Write, Mask Write with AP and MPC Write FIFO command in order to avoid the collision of Read and Write burst data on SDRAM's internal Data bus.

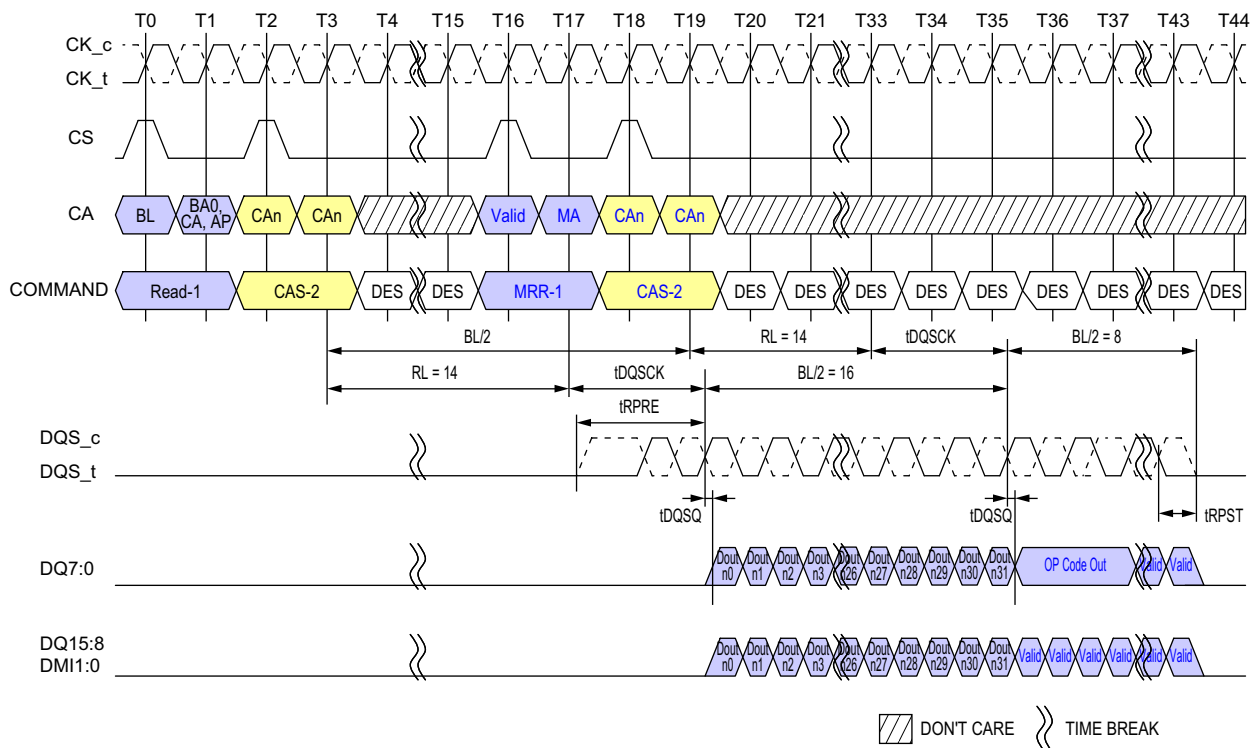

Note

1. The minimum number of clock cycles from the burst READ command to the MRR command is $BL/2$.
2. Read $BL = 32$, MRR $BL = 16$, $RL = 14$, Preamble = Toggle, Postamble = $0.5nCK$, $DBI = Disable$, $DQ/DQS: VSSQ$ termination
3. DES commands except tMRR period are shown for ease of illustration; other commands may be valid at these times.

Figure 79 - Read to MRR Timing

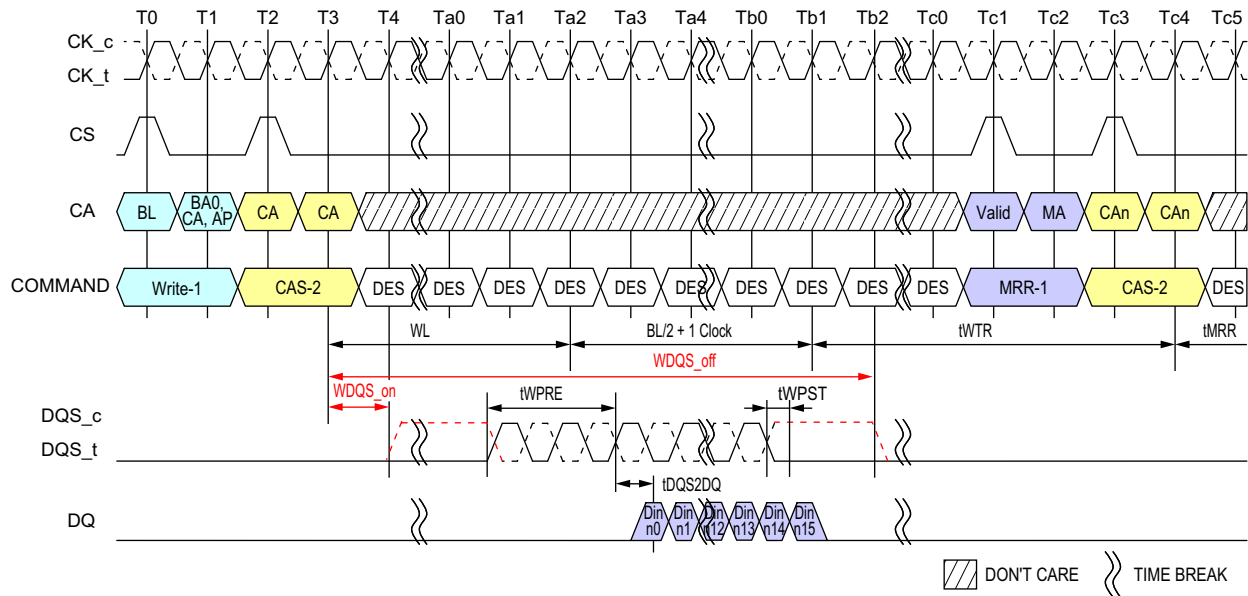

Note

1. Write BL=16, Write Postamble = 0.5nCK, DQ/DQS: VSSQ termination.
2. Only DES is allowed during tMRR period.
3. Din n = data-in to columnn n.
4. tWTR starts at the rising edge of CK after the last latching edge of DQS.
5. DES commands except tMRR period are shown for ease of illustration; other commands may be valid at these times.

Figure 80 - Write to MRR Timing

2.24.2. MRR after Power-Down Exit

Following the power-down state, an additional time, t_{MRRI} , is required prior to issuing the mode register read (MRR) command. This additional time (equivalent to t_{RCD}) is required in order to be able to maximize power-down current savings by allowing more power-up time for the MRR data path after exit from power down mode.

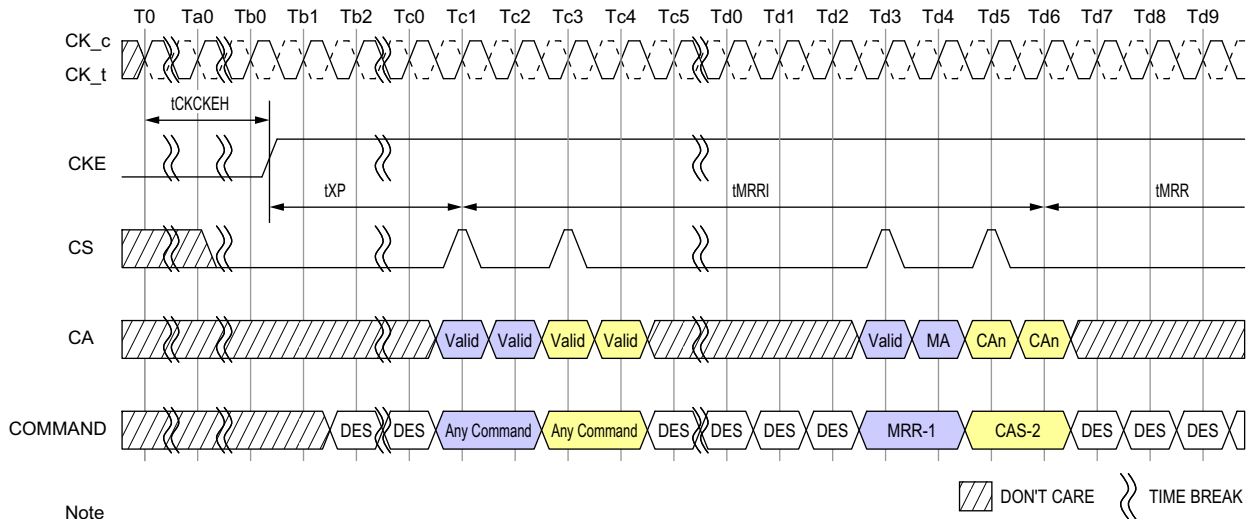

Figure 81 - MRR Following Power-Down

Table 48 - Mode Register Read/Write AC timing

Parameter	Symbol	min max	533	1066	1600	2133	2667	3200	3733	4266	Unit	Note
Additional time after t_{XP} has expired until the MRR command may be issued	t_{MRRI}	min	$t_{RCD} + 3nCK$								ns	
MODE REGISTER Read command period	t_{MRR}	min	8								nCK	
MODE REGISTER Write command period	t_{MRW}	min	$\max(10ns, 10nCK)$								ns	
Mode Register Write Set Command Delay	t_{MRD}	min	$\max(14ns, 10nCK)$								ns	

2.25. Mode Register Write (MRW) Operation

The Mode Register Write (MRW) command is used to write configuration data to the mode registers. The MRW command is initiated by setting CKE, CS, and CA[5:0] to valid levels at a rising edge of the clock (see Command Truth Table). The mode register address and the data written to the mode registers is contained in CA[5:0] according to the Command Truth Table. The MRW command period is defined by tMRW. Mode register Writes to read-only registers have no impact on the functionality of the device.

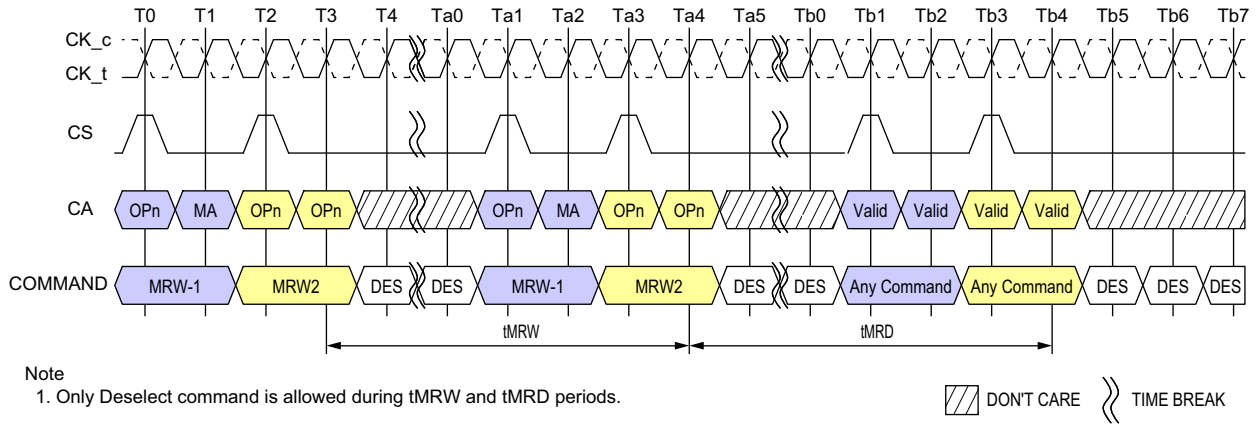

Figure 82 - Mode Register Write Timing

2.25.1. Mode Register Write

MRW can be issued from either a Bank-Idle or Bank-Active state. Certain restrictions may apply for MRW from an Active state.

Table 49 - Truth Table for Mode Register Read (MRR) and Mode Register Write (MRW)

Current State	Command	Intermediate State	Next State
SDRAM		SDRAM	SDRAM
All Banks Idle	MRR	Mode Register Reading (All Banks Idle)	All Banks Idle
	MRW	Mode Register Writing (All Banks Idle)	All Banks Idle
Bank(s) Active	MRR	Mode Register Reading	Bank(s) Active
	MRW	Mode Register Writing	Bank(s) Active

Table 50 - MRR/MRW Timing Constraints : DQ ODT Disabled

From Command	To Command	Minimum Delay between "From Command" and "To Command"	Unit	Notes
MRR	MRR	tMRR	-	
	RD/RDA	tMRR	-	
	WR/WRA/ MWR/MWRA	$RL+RU(tDQSCK(max)/tCK)+BL/2-WL+tWPRE+RD(tRPST)$	nCK	
	MRW	$RL+RU(tDQSCK(max)/tCK)+BL/2+ 3$	nCK	
RD/RDA	MRR	$BL/2$	nCK	
WR/WRA/ MWR/MWRA		$WL+1+BL/2+RU(tWTR/tCK)$	nCK	
MRW		tMRD	-	
Power Down Exit		tXP+tMRRI	-	
MRW	RD/RDA	tMRD	-	
	WR/WRA/ MWR/MWRA	tMRD	-	
	MRW	tMRW	-	
RD/ RD FIFO/ RD DQ CAL	MRW	$RL+BL/2+RU(tDQSCKmax/tCK) +RD(tRPST) +\max(RU(7.5ns/tCK),8nCK)$	nCK	
RD with Auto-Precharge		$RL+BL/2+RU(tDQSCKmax/tCK) +RD(tRPST) +\max(RU(7.5ns/tCK),8nCK)+nRTP-8$	nCK	
WR/ MWR/ WR FIFO		$WL+1+BL/2+\max(RU(7.5ns/tCK),8nCK)$	nCK	
WR/MWR with Auto-Precharge		$WL+1+BL/2+\max(RU(7.5ns/tCK),8nCK)+nWR$	nCK	

Table 51 - MRR/MRW Timing Constraints : DQ ODT Enabled

From Command	To Command	Minimum Delay between "From Command" and "To Command"	Unit	Notes
MRR	MRR	Same as ODT Disable Case	-	
	RD/RDA			
	WR/WRA/ MWR/MWRA	$RL+RU(tDQSCK(max)/tCK)+BL/2-ODTLon-RD(tODTon(min)/tCK)+RD(tRPST)+1$	nCK	
	MRW	Same as ODT Disable Case	-	
RD/RDA	MRR	Same as ODT Disable Case	-	
WR/WRA/ MWR/MWRA				
MRW				
Power Down Exit				
MRW	RD/RDA	Same as ODT Disable Case	-	
	WR/WRA/ MWR/MWRA			
	MRW			
RD/ RD FIFO/ RD DQ CAL	MRW	Same as ODT Disable Case	-	
RD with Auto-Precharge				
WR/ MWR/ WR FIFO				
WR/MWR with Auto-Precharge				

2.26. Vref Current Generator (VRCG)

LPDDR4 SDRAM V_{REF} current generators (VRCG) incorporate a high current mode to reduce the settling time of the internal VREF(DQ) and VREF(CA) levels during training and when changing frequency set points during operation. The high current mode is enabled by setting MR13[OP3] = 1. Only Deselect commands may be issued until tVRCG_ENABLE is satisfied. tVRCG_ENABLE timing is shown in Figure below.

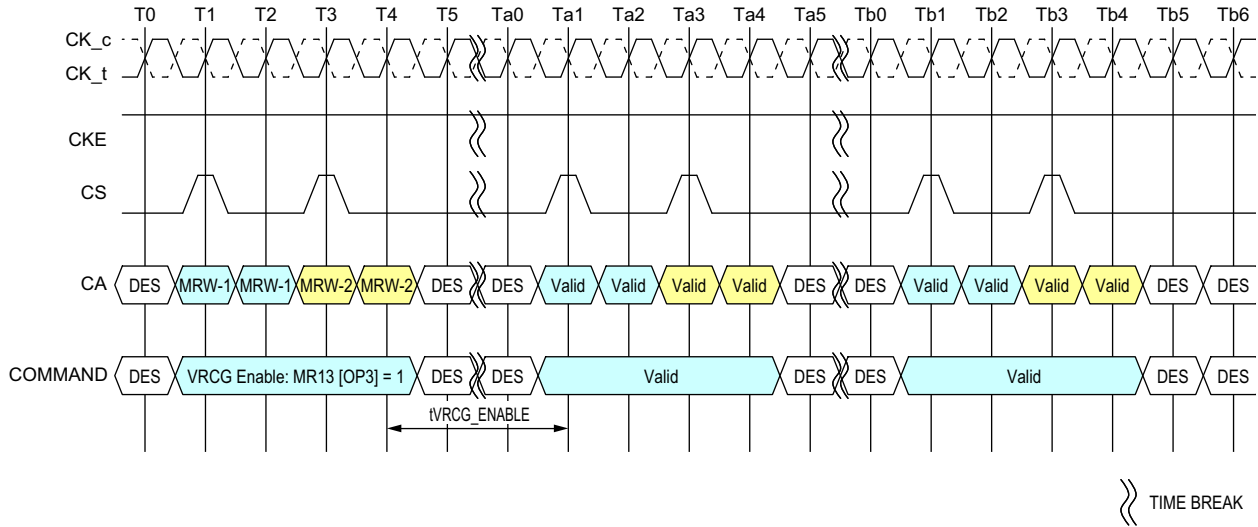

Figure 83 - VRCG Enable timing

VRCG high current mode is disabled by setting MR13[OP3] = 0. Only Deselect commands may be issued until tVRCG_DISABLE is satisfied. tVRCG_DISABLE timing is shown in figure below.

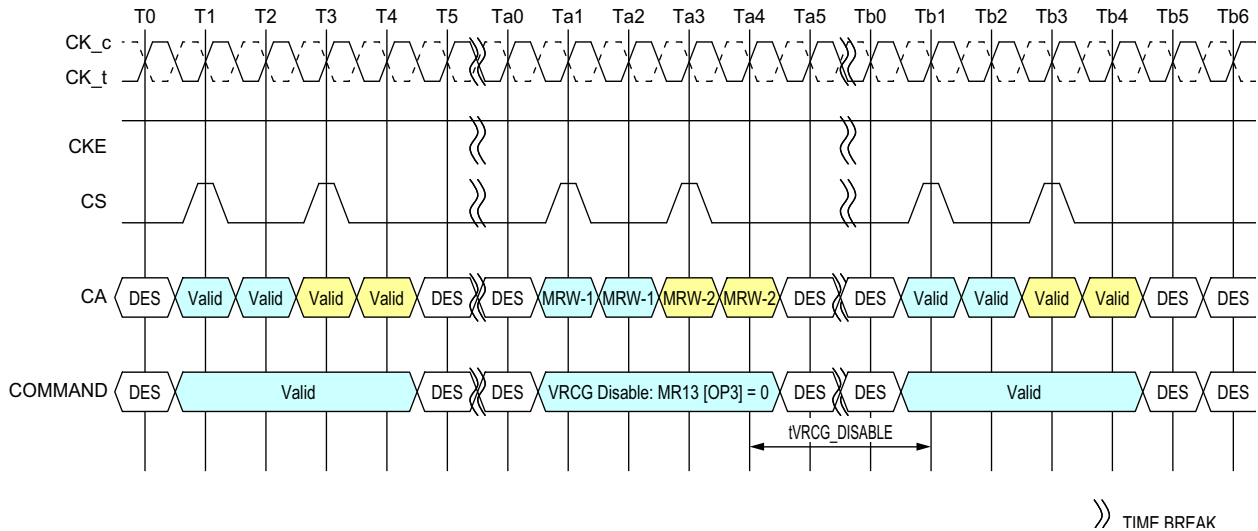

Figure 84 - VRCG Disable timing

Note that LPDDR4 SDRAM devices support VREF(CA) and VREF(DQ) range and value changes without enabling VRCG high current mode.

Table 52 - VRCG Enable/Disable Timing

Parameter	Symbol	min max	533	1066	1600	2133	2667	3200	3733	4266	Unit	Note
VREF high current mode enable time	tVRCG_Enable	max	200								ns	
VREF high current mode disable time	tVRCG_Disable	max	100								ns	

2.27. CA Vref Training

The DRAM internal CA Vref specification parameters are voltage operating range, step size, Vref set tolerance, Vref step time and Vref valid level.

The voltage operating range specifies the minimum required Vref setting range for LPDDR4 DRAM devices. The minimum range is defined by Vrefmax and Vrefmin as depicted in Figure "Vref operating range (Vref.min, Vref.max)".

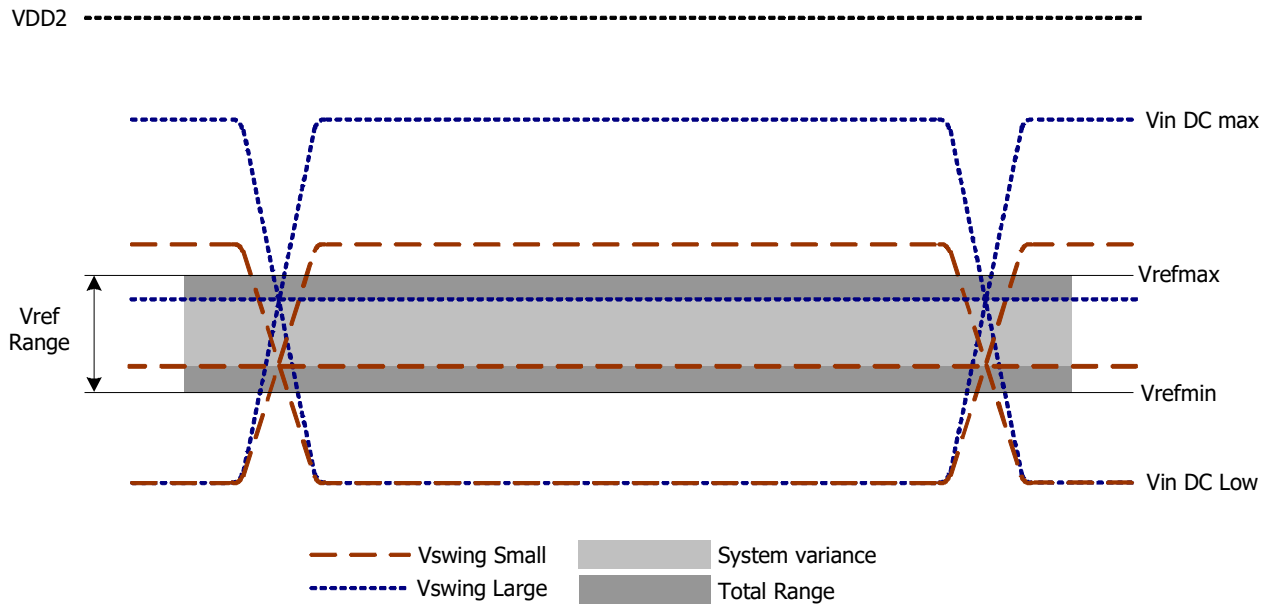

Figure 85 - Vref operating range (Vref.min, Vref.max)

The Vref stepsize is defined as the stepsize between adjacent steps. Vref stepsize ranges from 0.3% VDD2 to 0.5%VDD2. However, for a given design, DRAM has one value for Vref step size that falls within the range.

The Vref set tolerance is the variation in the Vref voltage from the ideal setting. This accounts for accumulated error over multiple steps. There are two ranges for Vref set tolerance uncertainty. The range of Vref set tolerance uncertainty is a function of number of steps n.

The Vref set tolerance is measured with respect to the ideal line which is based on the two endpoints. Where the endpoints are at the min and max Vref values for a specified range. An illustration depicting an example of the stepsize and Vref set tolerance is below.

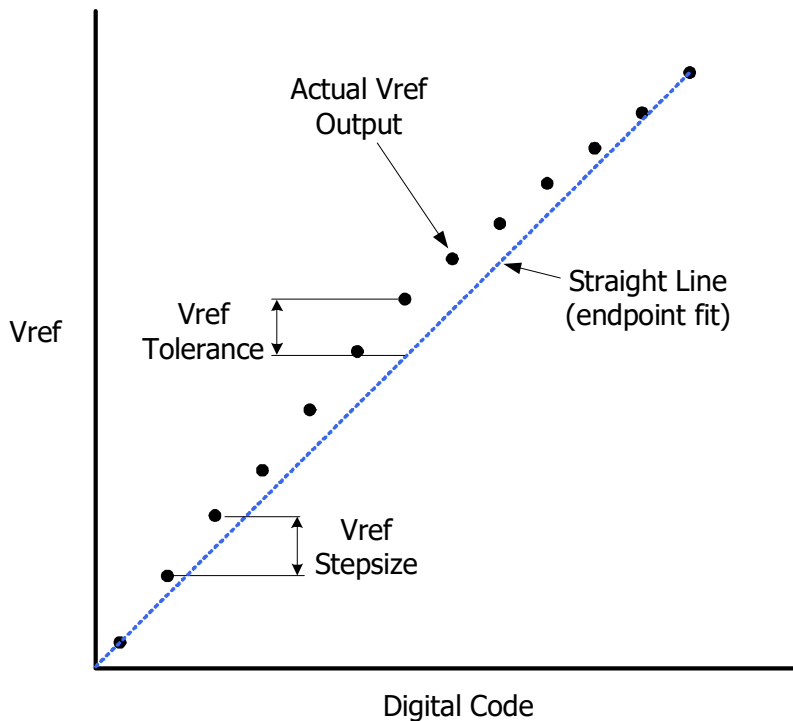

Figure 86 - Example of Vref set tolerance (max case only shown) and stepsize

The Vref increment/decrement step times are define by Vref_time-short, middle and long. The Vref_time-short, Vref_time-middle and Vref_time-long is defined from TS to TE as shown in the Figure "Vref_time for short, middlg and long timing diagram" below where TE is referenced to when the vref voltage is at the final DC level within the Vref valid tolerance (Vref_val_tol).

The Vref valid level is defined by Vref_val tolerance to qualify the step time TE as shown in Figure "Vref step single stepsize increment case". This parameter is used to insure an adequate RC time constant behavior of the voltage level change after any Vref increment/decrement adjustment. This parameter is only applicable for DRAM component level validation/characerization.

Vref_time-Short is for a single stepsize increment/decrement change in Vref voltage.

Vref_time-Middle is at least 2 stepsizes increment/decrement change within the same VrefCA range in Vref voltage.

Vref_time-Long is the time including up to Vrefmin to Vrefmax or Vrefmax to Vrefmin change across the VrefCA Range in Vref voltage.

TS - is referenced to MRS command clock

TE - is referenced to the Vref_val_tol

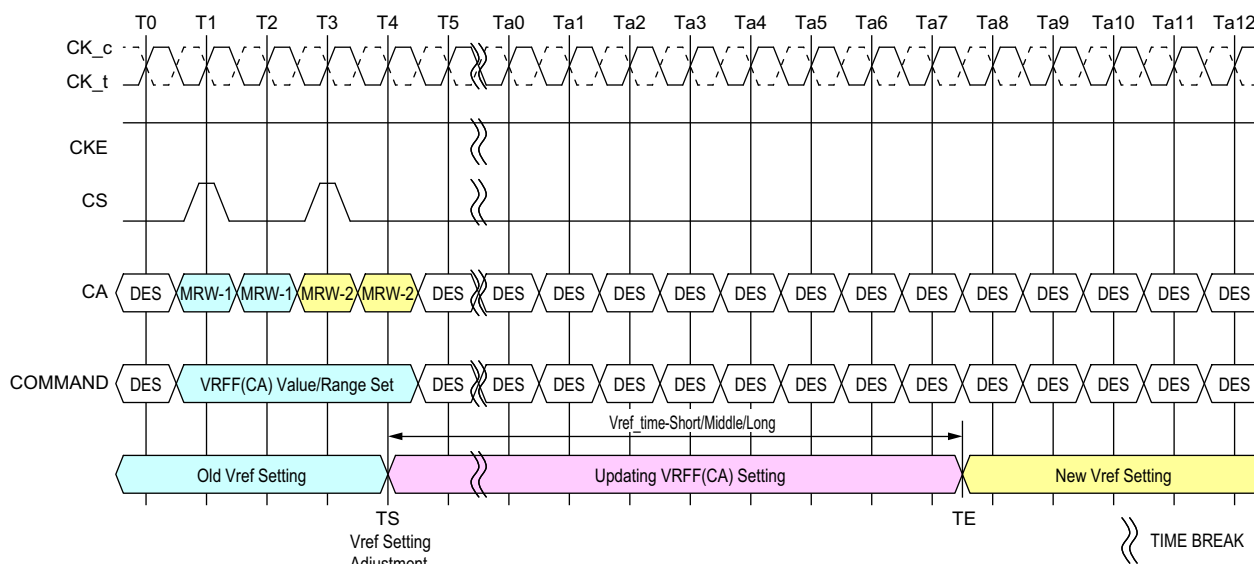

Figure 87 - Vref_time for short, middlg and long timing diagram

The MRW command to the mode register bits are as follows.

MR12 OP[5:0] : VREF(CA) Setting

MR12 OP[6] : VREF(CA) Range

The minimum time required between two Vref MRS commands is Vref_time-short for single step and Vref_time-Middle for a full voltage range step.

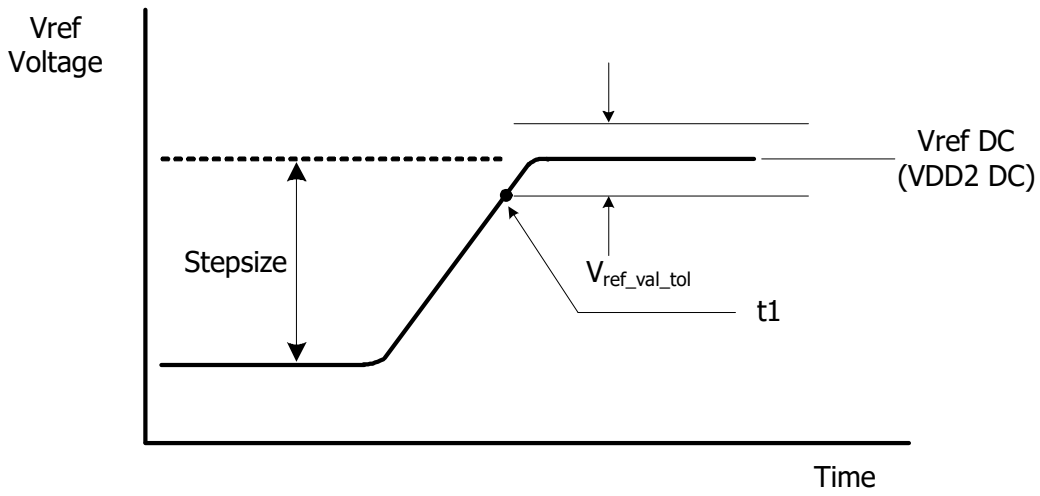

Figure 88 - Vref step single stepsize increment case

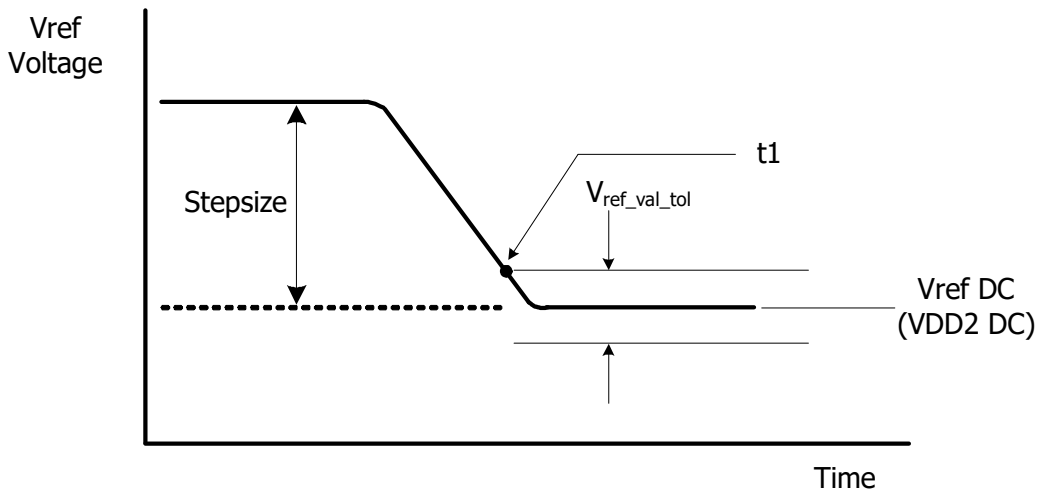

Figure 89 - Vref step single stepsize decrement case

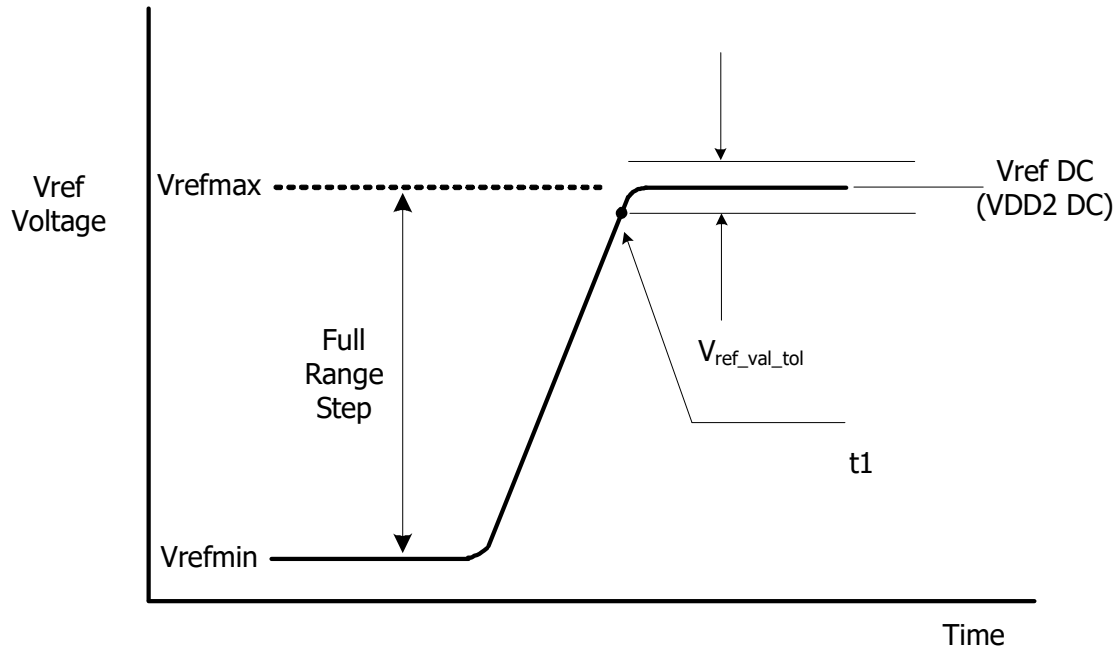

Figure 90 - Vref full step from Vrefmin to Vrefmax case

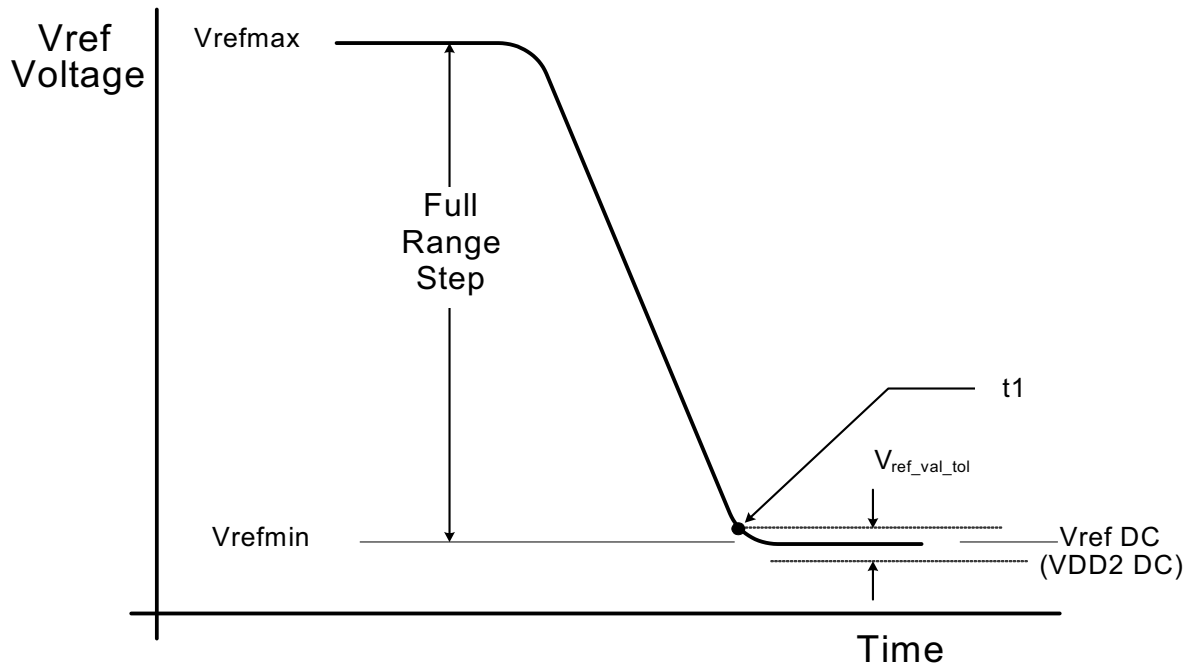

Figure 91 - Vref full step from Vrefmax to Vrefmin case

The table below contains the CA internal vref specifications that will be characterized at the component level for compliance. The component level characterization method is tbd.

Table 53 - CA Internal Vref Specifications

Parameter	Symbol	Min.	Typ.	Max.	Unit	Notes
Vref Max operating point Range[0]	Vref_max_R0	-	-	44.9%	VDDQ	1,11
Vref Min operating point Range[0]	Vref_min_R0	15%	-	-	VDDQ	1,11
Vref Max operating point Range[1]	Vref_max_R1	-	-	62.9%	VDDQ	1,11
Vref Min operating point Range[1]	Vref_min_R1	32.9%	-	-	VDDQ	1,11
Vref Steps ize	Vref_step	0.50%	0.60%	0.70%	VDDQ	2
Vref Set Tolerance	Vref_set_tol	-11	0	11	mV	3,4,6
		-1.1	0	1.1	mV	3,5,7
Vref Step Time	Vref_time-short	-	-	100	ns	8
	Vref_time-middle	-	-	200	ns	12
	Vref_time-Long	-	-	250	ns	9
	Vref_time-weak	-	-	1	ms	13,14
Vref Valid tolerance	Vref_val_tol	-0.10%	0.00%	0.10%	VDDQ	10

Notes

- Vref DC voltage referenced to VDDQ_DC.
- Vref stepsize increment/decrement range. Vref at DC level.
- $Vref_new = Vref_old + n * Vref_step$; n= number of steps; if increment use "+"; If decrement use "-".
- The minimum value of Vref setting tolerance = $Vref_new - 11mV$.
The maximum value of Vref setting tolerance = $Vref_new + 11mV$. For $n > 4$
- The minimum value of Vref setting tolerance = $Vref_new - 1.1mV$.
The maximum value of Vref setting tolerance = $Vref_new + 1.1mV$. For $n \leq 4$.
- Measured by recording the min and max values of the Vref output over the range, drawing a straight line between those points and comparing all other Vref output settings to that line.
- Measured by recording the min and max values of the Vref output across 4 consecutive steps($n=4$), drawing a straight line between those points and comparing all other Vref output settings to that line.
- Time from MRS command to increment or decrement one step size for Vref.
- Time from MRS command to increment or decrement Vrefmin to Vrefmax or Vrefmax to Vrefmin change across the VrefCA Range in Vref voltage.
- Only applicable for DRAM component level test/characterization purpose. Not applicable for normal mode of operation.
Vref valid is to qualify the step times which will be characterized at the component level.
- DRAM range 0 or 1 set by MR12 OP[6].
- Time from MRS command to increment or decrement more than one step size up a full range of Vref voltage within the same VrefCA range.
- Applies when VRCG high current mode is not enabled, specified by MR13 OP[3] = 0.
- Vref_time_weak covers all Vref(CA) Range and Value change conditions are applied to Vref_time_Short/Middle/Long.

2.28. DQ Vref Training

The DRAM internal DQ Vref specification parameters are voltage operating range, stepsize, Vref set tolerance, Vref step time and Vref valid level.

The voltage operating range specifies the minimum required Vref setting range for LPDDR4 DRAM devices. The minimum range is defined by Vrefmax and Vrefmin as depicted in Figure "Vref operating range (Vref.min, Vref.max)".

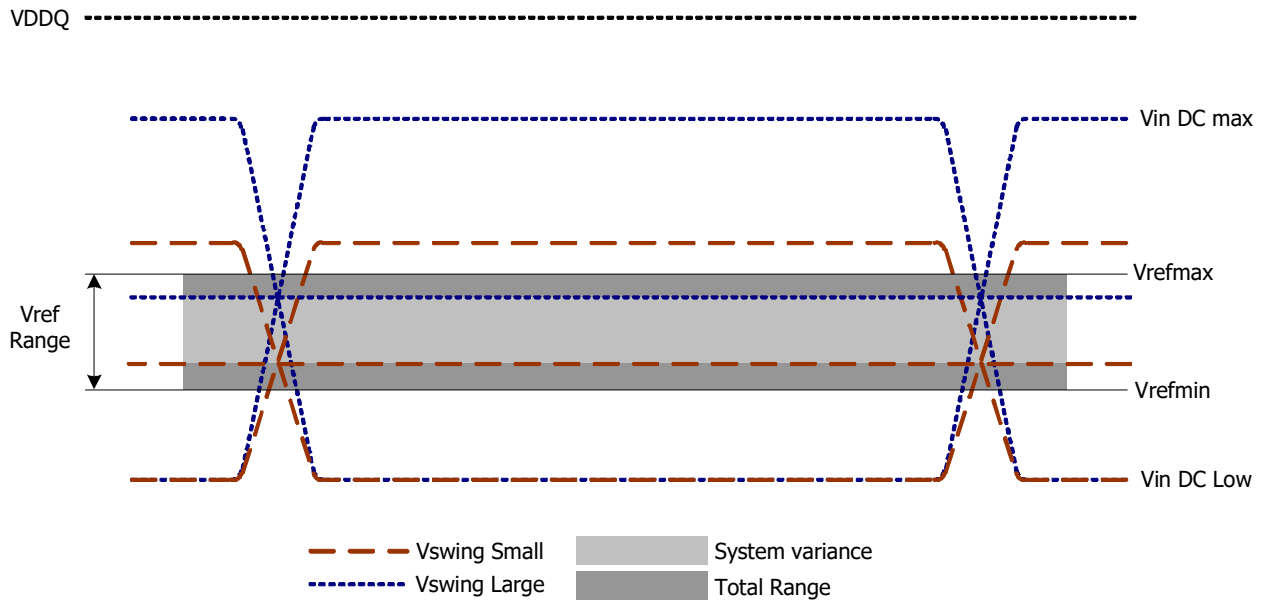

Figure 92 - Vref operating range (Vref.min, Vref.max)

The Vref stepsize is defined as the stepsize between adjacent steps. However, for a given design, DRAM has one value for Vref step size that falls within the range.

The Vref set tolerance is the variation in the Vref voltage from the ideal setting. This accounts for accumulated error over multiple steps. There are two ranges for Vref set tolerance uncertainty. The range of Vref set tolerance uncertainty is a function of number of steps n.

The Vref set tolerance is measured with respect to the ideal line which is based on the two endpoints. Where the endpoints are at the min and max Vref values for a specified range. An illustration depicting an example of the stepsize and Vref set tolerance is below.

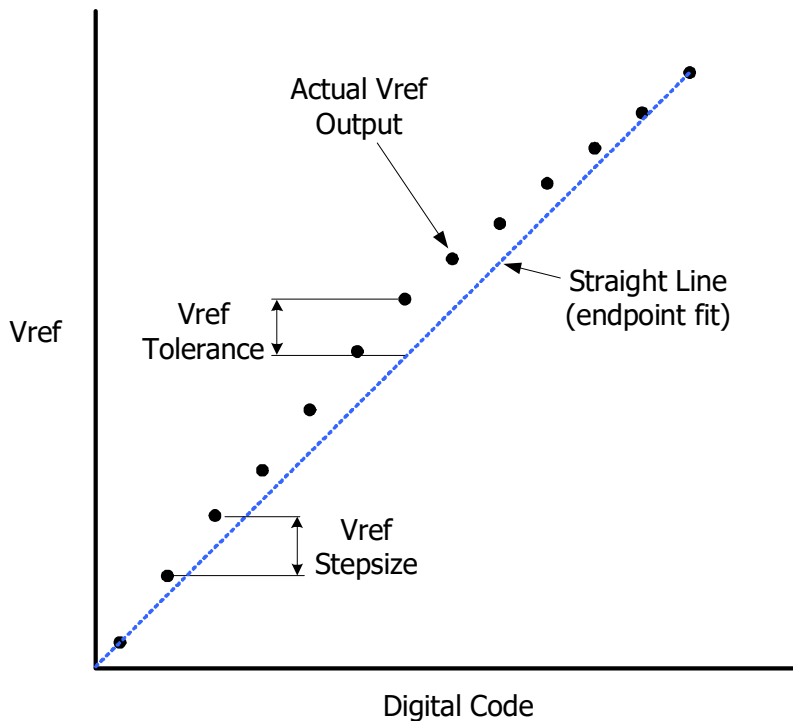

Figure 93 - Example of Vref set tolerance (max case only shown) and stepsize

The Vref increment/decrement step times are define by Vref_time-short, middle and long. The Vref_time-short, middle and Vref_time-long is defined from TS to TE as shown in the Figure "Vref_time for short and long timing diagram" below where TE is referencd to when the vref voltage is at the final DC level within the Vref valid tolerance(Vref_val_tol).

The Vref valid level is defined by Vref_val tolerance to qualify the step time TE as shown in Figure "Vref_time for short, middle, and long timing diagram". This parameter is used to insure an adequate RC time constant behavior of the voltage level change after any Vref increment/decrement adjustment. This parameter is only applicable for DRAM component level validation/characerization.

Vref_time-Short is for a single stepsize increment/decrement change in Vref voltage.

Vref_time-Middle is at least 2 stepsizes increment/decrement change within the same VrefDQ range in Vref voltage.

Vref_time-Long is the time including up to Vrefmin to Vrefmax or Vrefmax to Vrefmin change across the VrefDQ Range in Vref voltage.

TS - is referenced to MRS command clock

TE - is referenced to the Vref_val_tol

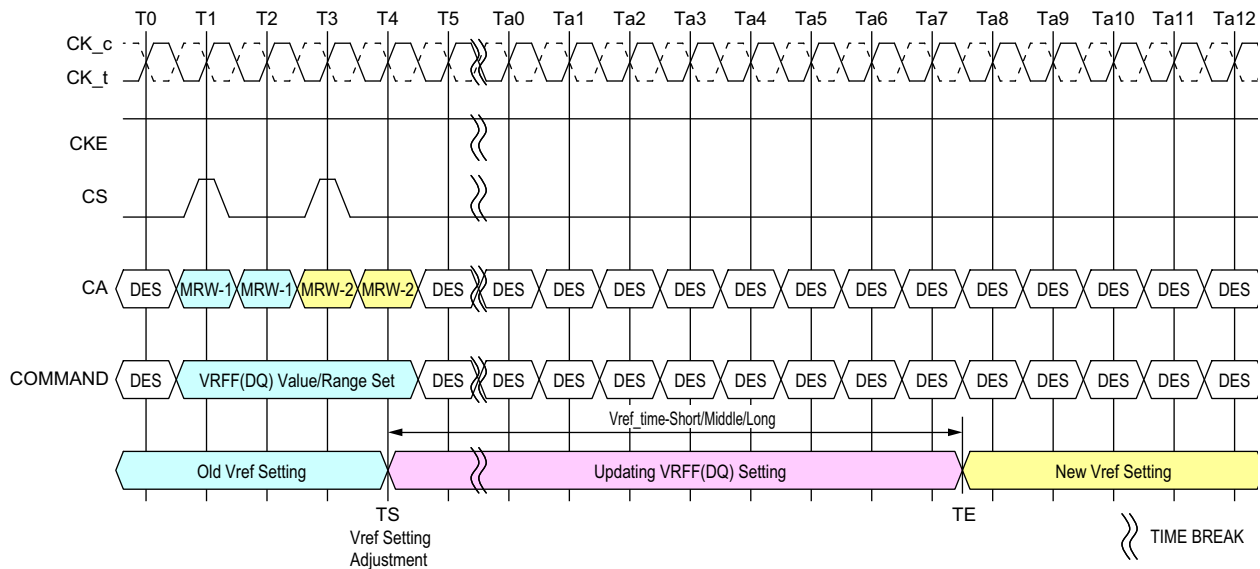

Figure 94 - Vref_time for short and long timing diagram

The MRW command to the mode register bits are as follows.

MR14 OP[5:0] : VREF(DQ) Setting

MR14 OP[6] : VREF(DQ) Range

The minimum time required between two Vref MRS commands is Vref_time-short for single step and Vref_time-Middle for a full voltage range step

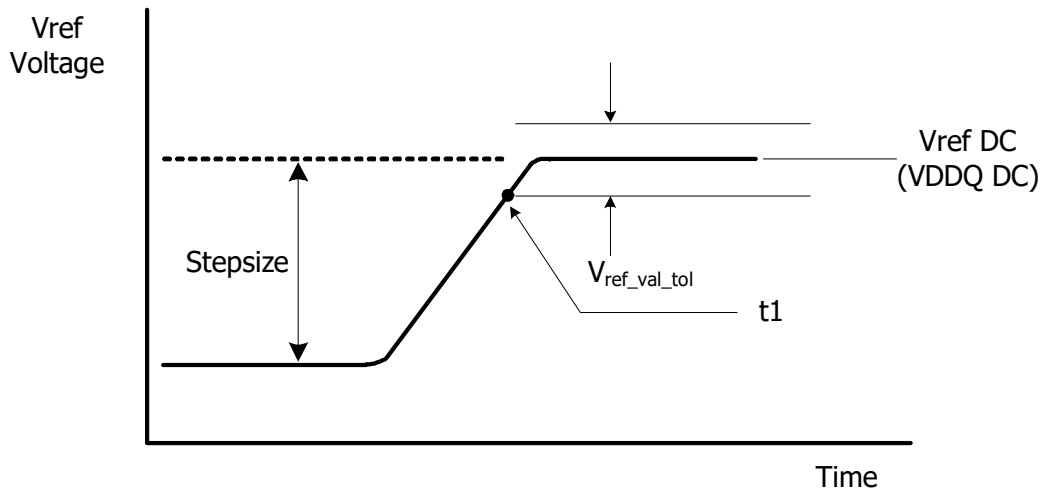

Figure 95 - Vref step single stepsize increment case

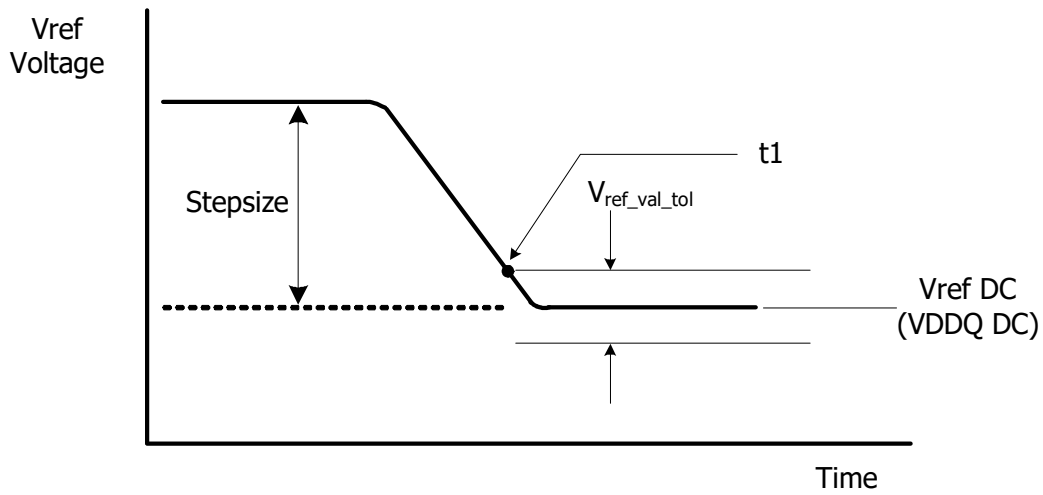

Figure 96 - Vref step single stepsize decrement case

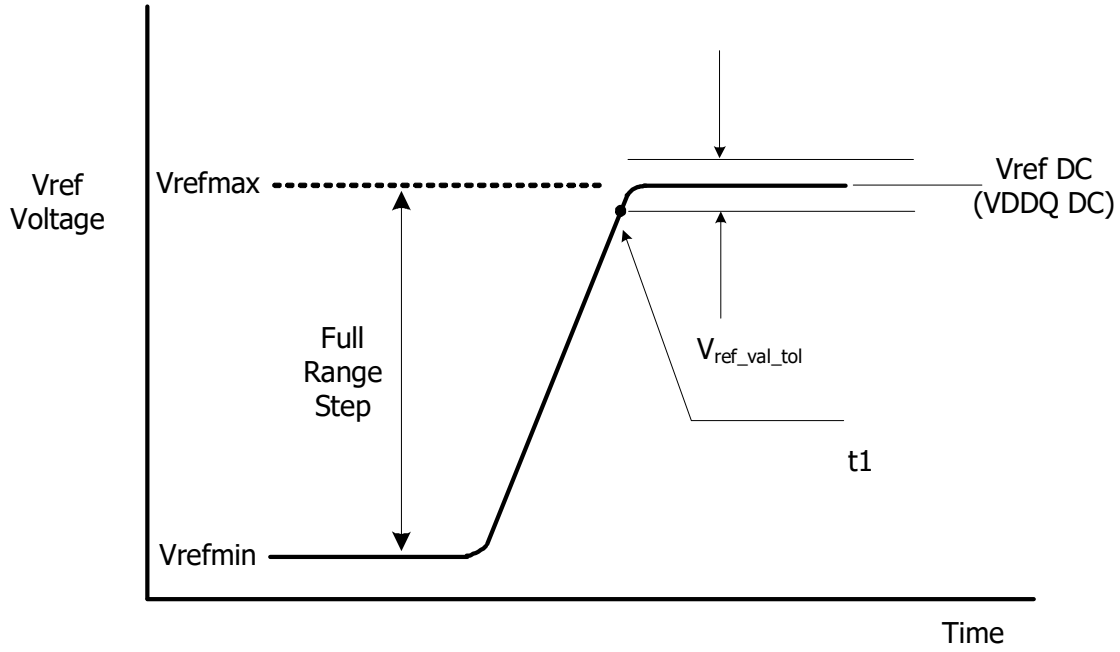

Figure 97 - Vref full step from Vrefmin to Vrefmax case

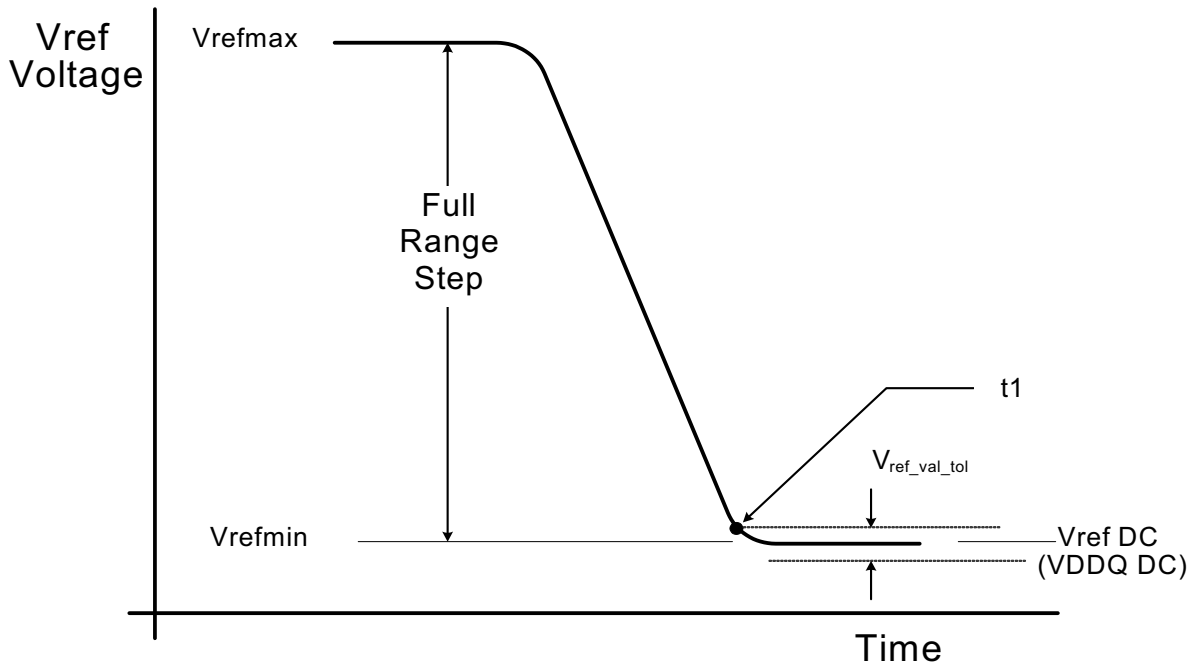

Figure 98 - Vref full step from Vrefmax to Vrefmin case

The table below contains the DQ internal vref specifications that will be characterized at the component level for compliance. The component level characterization method is tbd.

Table 54 - DQ Internal Vref Specifications

Parameter	Symbol	Min.	Typ.	Max.	Unit	Notes
Vref Max operating point Range[0]	Vref_max_R0	-	-	44.9%	VDDQ	1,11
Vref Min operating point Range[0]	Vref_min_R0	15%	-	-	VDDQ	1,11
Vref Max operating point Range[1]	Vref_max_R1	-	-	62.9%	VDDQ	1,11
Vref Min operating point Range[1]	Vref_min_R1	32.9%	-	-	VDDQ	1,11
Vref Step size	Vref_step	0.50%	0.60%	0.70%	VDDQ	2
Vref Set Tolerance	Vref_set_tol	-11	0	11	mV	3,4,6
		-1.1	0	1.1	mV	3,5,7
Vref Step Time	Vref_time-short	-	-	100	ns	8
	Vref_time-Middle	-	-	200	ns	12
	Vref_time-Long	-	-	250	ns	9
	Vref_time-weak	-	-	1	ms	13,14
Vref Valid tolerance	Vref_val_tol	-0.10%	0.00%	0.10%	VDDQ	10

Notes

- Vref DC voltage referenced to VDDQ_DC.
- Vref stepsize increment/decrement range. Vref at DC level.
- $Vref_new = Vref_old + n * Vref_step$; n= number of steps; if increment use "+"; If decrement use "-".
- The minimum value of Vref setting tolerance = $Vref_new - 11mV$.
The maximum value of Vref setting tolerance = $Vref_new + 11mV$. For $n > 4$.
- The minimum value of Vref setting tolerance = $Vref_new - 1.1mV$.
The maximum value of Vref setting tolerance = $Vref_new + 1.1mV$. For $n \leq 4$.
- Measured by recording the min and max values of the Vref output over the range, drawing a straight line between those points and comparing all other Vref output settings to that line.
- Measured by recording the min and max values of the Vref output across 4 consecutive steps($n=4$), drawing a straight line between those points and comparing all other Vref output settings to that line.
- Time from MRS command to increment or decrement one step size for Vref.
- Time from MRS command to increment or decrement Vrefmin to Vrefmax or Vrefmax to Vrefmin change across the VrefDQ Range in Vref voltage.
- Only applicable for DRAM component level test/characterization purpose. Not applicable for normal mode of operation.
Vref valid is to qualify the step times which will be characterized at the component level.
- DRAM range 0 or 1 set by MR14 OP[6].
- Time from MRS command to increment or decrement more than one step size up to a full range of Vref voltage within the same VrefDQ range.
- Applies when VRCG high current mode is not enabled, specified by $MR13[OP3] = 0$.
- Vref_time_weak covers all Vref(DQ) Range and Value change conditions are applied to Vref_time_Short/Middle/Long.

2.29. Command Bus Training

2.29.1. Command Bus Training for x16 mode

The LPDDR4-SDRAM command bus must be trained before enabling termination for high-frequency operation. LPDDR4 provides an internal VREF(CA) that defaults to a level suitable for un-terminated, low-frequency operation, but the VREF(CA) must be trained to achieve suitable receiver voltage margin for terminated, high-frequency operation. The training mode described here centers the internal VREF(CA) in the CA data eye and at the same time allows for timing adjustments of the CS and CA signals to meet setup/hold requirements. Because it can be difficult to capture commands prior to training the CA inputs, the training mode described here uses a minimum of external commands to enter, train, and exit the Command Bus Training mode.

Note: it is up to the system designer to determine what constitutes "low-frequency" and "high-frequency" based on the capabilities of the system. Low-frequency should then be defined as an operating frequency in which the system can reliably communicate with the SDRAM before Command Bus Training is executed.

The LPDDR4-SDRAM die has a bond-pad (ODT-CA) for multi-rank operation. In a multi-rank system, the terminating rank should be trained first, followed by the non-terminating rank(s). See the ODT section for more information.

The LPDDR4-SDRAM uses Frequency Set-Points to enable multiple operating settings for the die. The LPDDR4-SDRAM defaults to FSP-OP[0] at power-up, which has the default settings to operate in un-terminated, low-frequency environments. Prior to training, the mode register settings should be configured by setting MR13 OP[6]=1B (FSP-WR[1]) and setting all other mode register bits for FSP-OP[1] to the desired settings for high-frequency operation. Prior to entering Command Bus Training, the SDRAM will be operating from FSP-OP[x]. Upon Command Bus Training entry when CKE is driven LOW, the LPDDR4-SDRAM will automatically switch to the alternate FSP register set (FSP-OP[y]) and use the alternate register settings during training (See note 6 in Figure "Entering Command Bus Training Mode and CA Training Pattern Input and Output with VrefCA Value Update" for more information on FSP-OP register sets). Upon training exit when CKE is driven HIGH, the LPDDR4-SDRAM will automatically switch back to the original FSP register set (FSP-OP[x]), returning to the "known-good" state that was operating prior to training. The training values for VREF(CA) are not retained by the DRAM in FSP-OP[y] registers, and must be written to the registers after training exit.

1. To enter Command Bus Training mode, issue a MRW-1 command followed by a MRW-2 command to set MR13 OP[0]=1B (Command Bus Training Mode Enabled).

2. After time tMRD, CKE may be set LOW, causing the LPDDR4-SDRAM to switch from FSP-OP[x] to FSP-OP[y], and completing the entry into Command Bus Training mode.

A status of DQS_t, DQS_c, DQ and DMI are as follows, and DQ ODT state will be followed Frequency Set Point function except output pins.

- DQS_t[0], DQS_c[0] become input pins for capturing DQ[6:0] levels by its toggling.
- DQ[5:0] become input pins for setting VREF(CA) Level.
- DQ[6] becomes a input pin for setting VREF(CA) Range.
- DQ[7] and DMI[0] become input pins and their input level is Valid level or floating, either way is fine.
- DQ[13:8] become output pins to feedback its capturing value via command bus by CS signal.
- DQS_t[1], DQS_c[1], DMI[1] and DQ[15:14] become output pins or disable, it means that SDRAM may drive to a valid level or left floating.

3. At time tCAENT later, LPDDR4 SDRAM can accept to change its VREF(ca) Range and Value using input signals of DQS_t[0], DQS_c[0] and DQ[6:0] from existing value that's setting via MR12 OP[6:0]. The mapping between MR12 OP code and DQ signals is shown in the table below. At least one Vref CA setting is required before proceed to next training steps.

Table 55 - Mapping of MR12 OP Code and DQ Numbers

	Mapping						
MR12 OP code	OP6	OP5	OP4	OP3	OP2	OP1	OP0
DQ Number	DQ6	DQ5	DQ4	DQ3	DQ2	DQ1	DQ0

4. The new VREF(CA) value must “settle” for time tVREF_LONG before attempting to latch CA information.
5. To verify that the receiver has the correct VREF(CA) setting and to further train the CA eye relative to clock (CK), values latched at the receiver on the CA bus are asynchronously output to the DQ bus.
6. To exit Command Bus Training mode, drive CKE HIGH, and after time tVREF_LONG issue the MRW-1 command followed by the MRW-2 command to set MR13 OP[0]=0B. After time tMRW the LPDDR4-SDRAM is ready for normal operation. After training exit the LPDDR4-SDRAM will automatically switch back to the FSP-OP registers that were in use prior to training.

Command Bus Training may be executed from IDLE, or Self Refresh states. When executing CBT within the Self Refresh state, the SDRAM must not be a power down state (i.e. CKE must be HIGH prior to training entry). Command Bus Training entry and exit is the same, regardless of the SDRAM state from which CBT is initiated.

2.29.1.1. Training Sequence for single-rank systems:

Note that an example shown here is assuming an initial low-frequency, no-terminating operating point, training a high-frequency, terminating operating point. The green text is low-frequency, magenta text is high-frequency. Any operating point may be trained from any known good operating point

1. Set MR13 OP[6]=1B to enable writing to Frequency Set Point ‘y’ (FSP-WR[y]) (or FSP-OP[x], See note).
2. Write FSP-WR[y] (or FSP-WR[x]) registers for all channels to set up high-frequency operating parameters.
3. Issue MRW-1 and MRW-2 commands to enter Command Bus Training mode.
4. Drive CKE LOW, and change CK frequency to the high-frequency operating point.
5. Perform Command Bus Training (V_{REFCA}, CS, and CA).
6. Exit training, a change CK frequency to the low-frequency operating point prior to driving CKE HIGH, then issue MRW-1 and MRW-2 commands. When CKE is driven HIGH, the SDRAM will automatically switch back to the FSP-OP registers that were in use prior to training (i.e. trained values are not retained by the SDRAM).
7. Write the trained values to FSP-WR[y] (or FSP-WR[x]) by issuing MRW-1 and MRW-2 commands to the SDRAM and setting all applicable mode register parameters.
8. Issue MRW-1 and MRW-2 commands to switch to FSP-OP[y] (or FSP-OP[x]), to turn on termination, and change CK frequency to the high frequency operating point. At this point the Command Bus is trained and you may proceed to other training or normal operation.

2.29.1.2. Training Sequence for multi-rank systems:

(Example shown here is assuming an initial low-frequency operating point, training a high-frequency operating point. The green text is low-frequency, magenda text is high-frequency. Any operating point may be trained from any known good operating point)

1. Set MR13 OP[6]=1B to enable writing to Frequency Set Point 'y' (FSP-WR[y]) (or FSP-WR[x], See Note).
2. Write FSP-WR[y] (or FSP-WR[x]) registers for the channel and ranks to set up high frequency operating parameters.
3. Read MR0 OP[7] on the channel and ranks to determine which die are terminating, signified by MR0 OP[7]=1B.
4. Issue MRW-1 and MRW-2 commands to enter Command Bus Training mode on the terminating rank.
5. Drive CKE LOW on the terminating rank (or all ranks), and change CK frequency to the high-frequency operating point.
6. Perform Command Bus Training on the terminating rank (VREFca, CS, and CA).
7. Exit training by driving CKE HIGH, change CK frequency to the low-frequency operating point, and issue MRW-1 and MRW-2 commands to write the trained values to FSP-WR[y] (or FSP-WR[x]). When CKE is driven HIGH, the SDRAM will automatically switch back to the FSP-OP registers that were in use prior to training (i.e. trained values are not retained by the SDRAM).
8. Issue MRW-1 and MRW-2 command to enter training mode on the non-terminating rank (but keep CKE HIGH)
9. Issue MRW-1 and MRW-2 commands to switch the terminating rank to FSP-OP[y] (or FSP-OP[x]), to turn on termination, and change CK frequency to the highfrequency operating point.
10. Drive CKE LOW on the non-terminating (or all) ranks. The non-terminating rank(s) will now be using FSP-OP[y] (or FSP-OP[x]).
11. Perform Command Bus Training on the non-terminating rank (VREFca, CS, and CA).
12. Issue MRW-1 and MRW-2 commands to switch the terminating rank to FSP-OP[x] (or FSP-OP[y]) to turn off termination.
13. Exit training by driving CKE HIGH on the non-terminating rank, change CK frequency to the low-frequency operating point, and issue MRW-1 and MRW-2 commands. When CKE is driven HIGH, the SDRAM will automatically switch back to the FSP-OP registers that were in use prior to training (i.e. trained values are not retained by the SDRAM).
14. Write the trained values to FSP-WR[y] (or FSP-WR[x]) by issuing MRW-1 and MRW-2 commands to the SDRAM and setting all applicable mode register parameters.
15. Issue MRW-1 and MRW-2 commands to switch the terminating rank to FSP-OP[y] (or FSP-OP[x]), to turn on termination, and change CK frequency to the highfrequency operating point. At this point the Command Bus is trained for both ranks and you may proceed to other training or normal operation.

2.29.1.3. Relation between CA input pin and DQ output pin

The relation between CA input pin and DQ out pin is shown in the following table.

Table 56 - Mapping of CA input pin to DQ ouput pin

	Mapping					
CA Number	CA5	CA4	CA3	CA2	CA1	CA0
DQ Number	DQ13	DQ12	DQ11	DQ10	DQ9	DQ8

2.29.1.4. Timing Diagram

The basic timing diagrams of Command Bus Training are shown in following figures.

Figure 99 - Entering Command Bus Training Mode and CA Training Pattern Input and Output

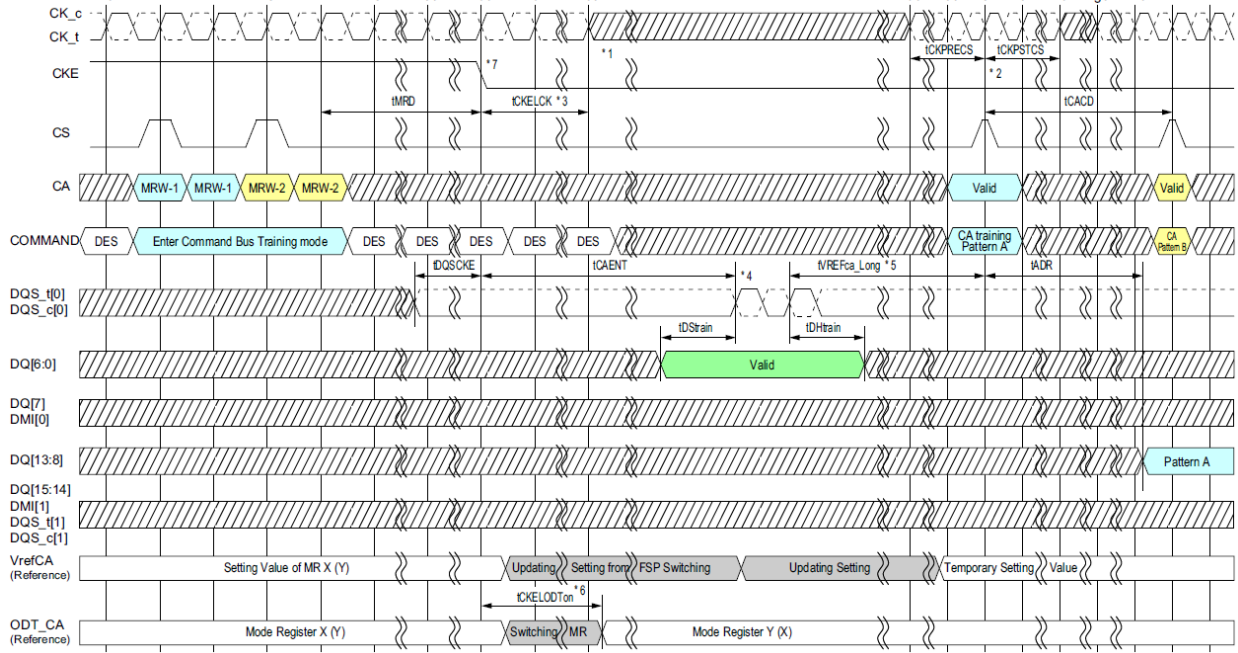

Notes

1. After tCKELCK clock can be stopped or frequency changed any time.
2. The input clock condition should be satisfied tCKPRECS and tCKPSTCS.
3. Continue to Drive CK and Hold CS pins low until tCKELCK after CKE is low (which disables command decoding).
4. DRAM may or may not capture first rising/falling edge of DQS_t/c due to an unstable first rising edge. Hence provide at least consecutive 2 pulses of DQS signal input in every DQS input signal at capturing DQ6:0 signals. The captured value of DQ6:0 signal level by each DQS edges are overwritten at any time and the DRAM updates its VREFca setting of MR12 temporary after time tVREFca_Long.
5. tVREF_LONG may be reduced to tVREF_SHORT if the following conditions are met: 1) The new Vref setting is a single step above or below the old Vref setting, and 2) The DQS pulses a single time, or the new Vref setting value on DQ[6:0] is static and meets tDSTRAIN/tDHTRAIN for every DQS pulse applied.
6. When CKE is driven LOW, the SDRAM will switch its FSP-OP registers to use the alternate (i.e. non-active) set. Example: If the SDRAM is currently using FSP-OP[0], then it will switch to FSP-OP[1] when CKE is driven LOW. All operating parameters should be written to the alternate mode registers before entering Command Bus Training to ensure that ODT settings, RL/WL/nWR setting, etc., are set to the correct values. If the alternate FSP-OP has ODT_CA disabled then termination will not enable in CA Bus Training mode. If the ODT_CA pad is bonded to Vss, ODT_CA termination will never enable for that die.
7. When CKE is driven low in Command Bus Training mode, the LPDDR4-SDRAM will change operation to the alternate FSP, i.e. the inverse of the FSP programmed in the FSP-OP mode register.

Figure 100 - Consecutive VrefCA Value Update

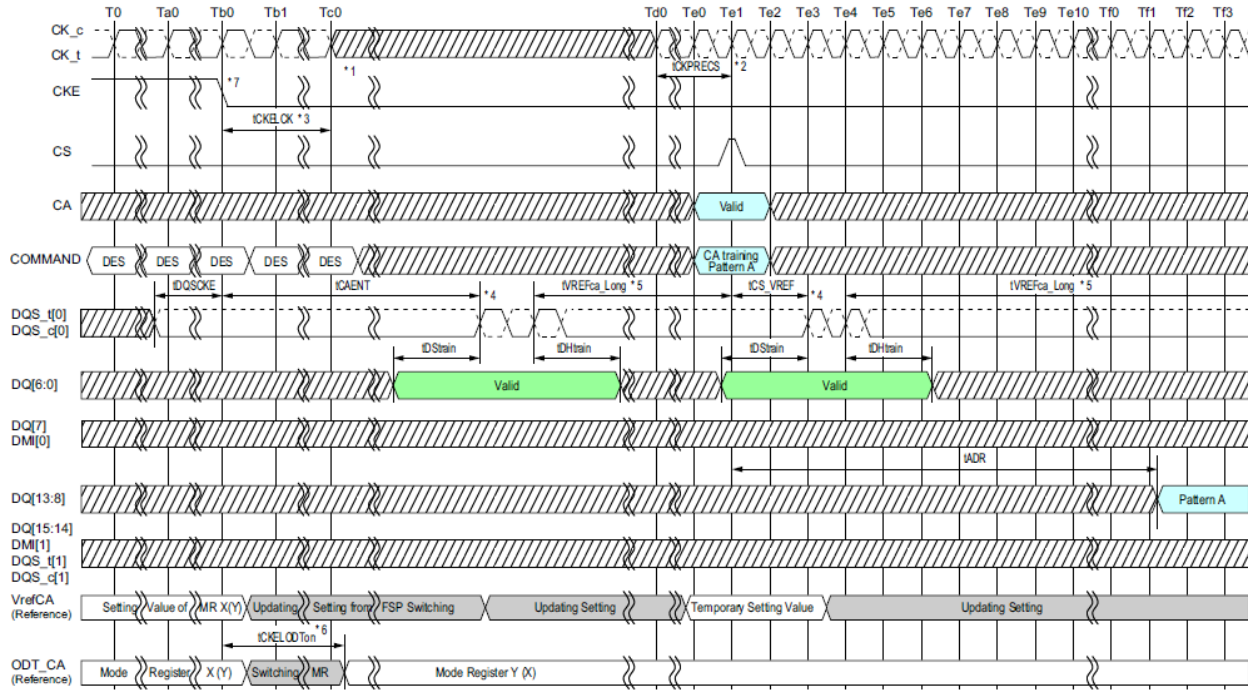

Notes

1. After tCKELCK clock can be stopped or frequency changed any time.
2. The input clock condition should be satisfied tCKPRECS.
3. Continue to Drive CK and Hold CS pins low until tCKELCK after CKE is low (which disables command decoding).
4. DRAM may or may not capture first rising/falling edge of DQS_t/c due to an unstable first rising edge. Hence provide at least consecutive 2 pulses of DQS signal input is required in every DQS input signal at capturing DQ6:0 signals. The captured value of DQ6:0 signal level by each DQS edges are overwritten at any time and the DRAM updates its VREFca setting of MR12 temporary after time tVREFca_Long.
5. tVREF_LONG may be reduced to tVREF_SHORT if the following conditions are met: 1) The new Vref setting is a single step above or below the old Vref setting, and 2) The DQS pulses a single time, or the new Vref setting value on DQ[6:0] is static and meets tDSTRAIN/tDHTRAIN for every DQS pulse applied.
6. When CKE is driven LOW, the SDRAM will switch its FSP-OP registers to use the alternate (i.e. non-active) set. Example: If the SDRAM is currently using FSP-OP[0], then it will switch to FSP-OP[1] when CKE is driven LOW. All operating parameters should be written to the alternate mode registers before entering Command Bus Training to ensure that ODT settings, RL/WL/nWR setting, etc., are set to the correct values. If the alternate FSP-OP has ODT_CA disabled then termination will not enable in CA Bus Training mode. If the ODT_CA pad is bonded to Vss, ODT_CA termination will never enable for that die.
7. When CKE is driven low in Command Bus Training mode, the LPDDR4-SDRAM will change operation to the alternate FSP, i.e. the inverse of the FSP programmed in the FSP-OP mode register.

Figure 101 - Exiting Command Bus Training Mode with Valid Command

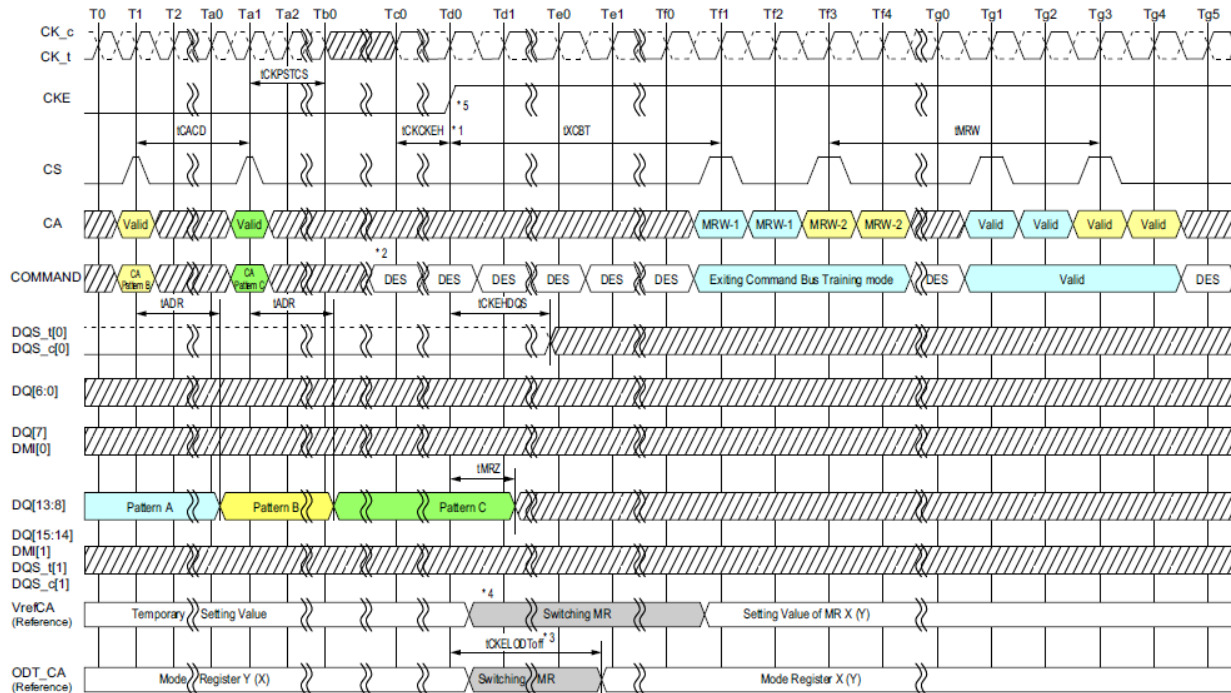

NOTES :

1. Clock can be stopped or frequency changed any time before tCKCKEH. CK must meet tCKCKEH before CKE is driven high. When CKE is driven high the clock frequency must be returned to the original frequency (the frequency corresponding to the FSP at which Command Bus Training mode was entered)
2. CS must be Deselect (low) tCKCKEH before CKE is driven high.
3. When CKE is driven high, the SDRAM's ODT_CA will revert to the state/value defined by FSP-OP prior to Command Bus Training mode entry, i.e. the original frequency set point (FSP-OP, MR13-OP[7]). Example: If the SDRAM was using FSP-OP[1] for training, then it will switch to FSP-OP[0] when CKE is driven HIGH.
4. Training values are not retained by the SDRAM, and must be written to the FSP-OP register set before returning to operation at the trained frequency. Example: VREF(CA) will return to the value programmed in the original set point.
5. When CKE is driven high the LPDDR4-SDRAM will revert to the FSP in operation when Command Bus Training mode was entered.

Figure 102 - Exiting Command Bus Training Mode with Power Down Entry

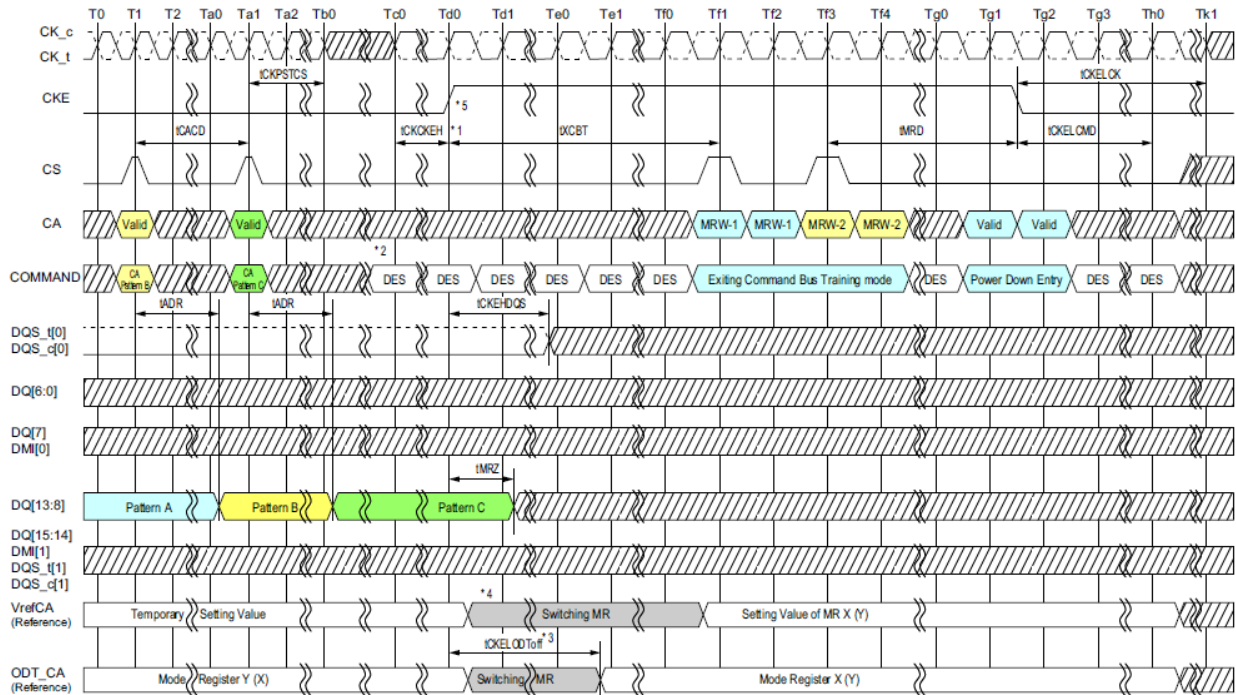

NOTES :

1. Clock can be stopped or frequency changed any time before tCKCKEH. CK must meet tCKCKEH before CKE is driven high. When CKE is driven high the clock frequency must be returned to the original frequency (the frequency corresponding to the FSP at which Command Bus Training mode was entered)
2. CS must be Deselect (low) tCKCKEH before CKE is driven high.
3. When CKE is driven high, the SDRAM's ODT_CA will revert to the state/value defined by FSP-OP prior to Command Bus Training mode entry, i.e. the original frequency set point (FSP-OP, MR13-OP[7]). Example: If the SDRAM was using FSP-OP[1] for training, then it will switch to FSP-OP[0] when CKE is driven HIGH.
4. Training values are not retained by the SDRAM, and must be written to the FSP-OP register set before returning to operation at the trained frequency. Example: VREF(CA) will return to the value programmed in the original set point.
5. When CKE is driven high the LPDDR4-SDRAM will revert to the FSP in operation when Command Bus Training mode was entered.

2.29.1.5. Command Bus Training AC timing Table
Table 57 - Command Bus Training Parameters

Parameter	Symbol	min max	533	1066	1600	2133	2667	3200	3733	4266	Unit	Note
Valid Clock Requirement after CKE Input low	tCKELCK	min	max(5ns, 5nCK)								tCK	
Data Setup for V _{REF} Training Mode	tDStrain	min	2								ns	
Data Hold for V _{REF} Training Mode	tDHtrain	min	2								ns	
Asynchronous Data Read	tADR	max	20								ns	
CA Bus Training Command to CA Bus Training Command Delay	tCACD	min	RU (tADR/tCK)								tCK	2
Valid Strobe Requirement before CKE Low	tDQSCKE	min	10								ns	1
First CA Bus Training Command Following CKE Low	tCAENT	min	250								ns	
V _{REF} Step Time – multiple steps	tVrefCA_long	max	250								ns	
V _{REF} Step Time – one step	tVrefCA_short	max	80								ns	
Valid Clock Requirement before CS High	tCKPRECS	min	2*tCK + tXP (tXP = max(7.5ns, 5nCK))								-	
Valid Clock Requirement after CS High	tCKPSTCS	min	max (7.5ns, 5nCK)								-	
Minimum delay from CS to DQS toggle in command bus training	tCS_Vref	min	2								tCK	
Minimum delay from CKE High to Strobe High Impedance	tCKEHDQS	min	10								ns	
Valid Clock Requirement before CKE Input High	tCKCKEH	min	max(1.75ns, 3nCK)								tCK	
CA Bus Training CKE High to DQ Tri-state	tMRZ	min	1.5								ns	
ODT turn-on Latency from CKE	tCKELODTon	min	20								ns	
ODT turn-off Latency from CKE	tCKELODToff	min	20								ns	
Exit Command Bus Training Mode to next valid command delay	tXCBT_Short	Min	Max(5nCK, 200ns)								-	3
	tXCBT_Middle	Min	Max(5nCK, 200ns)								-	3
	tXCBT_Long	Min	Max(5nCK, 200ns)								-	3

Notes

1. DQS_t has to retain a low level during tDQSCKE period, as well as DQS_c has to retain a high level.
2. If tCACD is violated, the data for samples which violate tCACD will not be available, except for the last sample (where tCACD after this sample is met). Valid data for the last sample will be available after tADR.
3. Exit Command Bus Training Mode to next valid command delay Time depends on value of VREF(CA) setting: MR12 OP[5:0] and VREF(CA) Range: MR12 OP[6] of FSP-OP 0 and 1. Additionally exit Command Bus Training Mode to next valid command delay Time may affect VREF(DQ) setting. Settling time of VREF(DQ) level is same as VREF(CA) level.

2.29.2. Command Bus Training for x8 mode

The LPDDR4-SDRAM command bus must be trained before enabling termination for high-frequency operation. LPDDR4 provides an internal VREF(ca) that defaults to a level suitable for un-terminated, low-frequency operation, but the VREF(ca) must be trained to achieve suitable receiver voltage margin for terminated, high-frequency operation. The training methodology described here centers the internal VREF(ca) in the CAdat eye and at the same time allows for timing adjustments of the CS and CA signals to meet setup/hold requirements. Because it can be difficult to capture commands prior to training the CA inputs, the training methodology described here uses a minimum of external commands to enter, train, and exit the Command Bus Training methodology.

Note: it is up to the system designer to determine what constitutes “low-frequency” and “high-frequency” based on the capabilities of the system. Low-frequency should then be defined as an operating frequency in which the system can reliably communicate with the SDRAM before Command Bus Training is executed.

The Byte mode LPDDR4-SDRAM (x8 2ch.) is supported two Command Bus Training (CBT) modes and their feature is as follows.

Mode1: DQ[6:0] only uses as output and VrefCA input procedure removes from CBT function of x16 2ch. device.

Mode2: The status (Input or Output) of DQ[6:0] is controlled by DQ[7] pin.

Above-mentioned CBT mode is selected by MRx [OPy].

The LPDDR4-SDRAM die has a bond-pad (ODT-CA) for multi-rank operation. In a multi-rank system, the terminating rank should be trained first, followed by the nonterminating rank(s). See the ODT section for more information.

The corresponding DQ pins in this definition depends on the package configuration. DQ0 becomes DQ8 in some cases, as well as DQ1 to DQ6.

2.29.2.1. Training Mode 1

The LPDDR4-SDRAM uses Frequency Set-Points to enable multiple operating settings for the die. The LPDDR4-SDRAM defaults to FSP-OP[0] at power-up, which has the default settings to operate in un-terminated, low-frequency environments. Prior to training, the mode register settings should be configured by setting MR13 OP[6]=1B (FSP-WR[1]) and setting all other mode register bits including MR12 OP[6:0] (VREF(CA) Range and Setting) for FSP-OP[1] to the desired settings for high-frequency operation. Prior to entering Command Bus Training, the SDRAM will be operating from FSP-OP[x]. Upon Command Bus Training entry when CKE is driven LOW, the LPDDR4-SDRAM will automatically switch to the alternate FSP register set (FSP-OP[y]) and use the alternate register settings during training (See note 6 in Figure 52 for more information on FSP-OP register sets). Upon training exit when CKE is driven HIGH, the LPDDR4-SDRAM will automatically switch back to the original FSP register set (FSP-OP[x]), returning to the “known-good” state that was operating prior to training.

1. To set MRx OP[y] = 0: CBT Training Mode 1
2. To enter Command Bus Training mode, issue a MRW-1 command followed by a MRW-2 command to set MR13 OP[0]=1B (Command Bus Training Mode Enabled).
3. After time tMRD, CKE may be set LOW, causing the LPDDR4-SDRAM to switch from FSP-OP[x] to FSP-OP[y], and completing the entry into Command Bus Training mode.

A status of DQS_t, DQS_c, DQ and DMI are as follows, and DQ ODT state will be followed Frequency Set Point function except output pins.

4. At time tCAENT later, LPDDR4 SDRAM can accept to input CA training pattern via CA bus.
5. To verify that the receiver has the correct VREF(ca) setting and to further train the CA eye relative to clock (CK), values latched at the receiver on the CA bus are asynchronously output to the DQ bus.
6. To exit Command Bus Training mode, drive CKE HIGH, and after time tXCBT issue the MRW-1 command followed by the MRW-2 command to set MR13 OP[0]=0B. After time tMRW the LPDDR4-SDRAM is ready for normal operation. After training exit the LPDDR4-SDRAM will automatically switch back to the FSP-OP registers that were in use prior to training.

Command Bus Training may be executed from IDLE or Self Refresh states. When executing CBT within the Self Refresh state, the SDRAM must not be in a power down state (i.e. CKE must be HIGH prior to training entry). Command Bus Training entry and exit is the same, regardless of the SDRAM state from which CBT is initiated.

2.29.2.1.1. Training Sequence of mode 1 for single-rank systems

Note that an example shown here is assuming an initial low-frequency, non-terminating operating point, training a high-frequency, terminating operating point. **The green text is low-frequency, magenta text is high-frequency.** Any operating point may be trained from any known good operating point.

1. Set MR13 OP[6]=1B to enable writing to Frequency Set Point 'y' (FSP-WR[y]) (or FSP-OP[x], See note).
2. Write FSP-WR[y] (or FSP-OP[x]) registers for the channel to set up high-frequency operating parameters including VREF(CA) Range and Setting.
3. Issue MRW-1 and MRW-2 commands to enter Command Bus Training mode.
4. Drive CKE LOW, and change CK frequency to the high-frequency operating point.
5. Perform Command Bus Training (CS, and CA).
6. Exit training, a change CK frequency to the low-frequency operating point prior to driving CKE HIGH, then issue MRW-1 and MRW-2 commands. When CKE is driven HIGH, the SDRAM will automatically switch back to the FSP-OP registers that were in use prior to training (i.e. trained values are not retained by the SDRAM).
7. Issue MRW-1 and MRW-2 commands to switch to FSP-OP[y] (or FSP-OP[x]), to turn on termination, and change CK frequency to the high frequency operating point. At this point the Command Bus is trained and you may proceed to other training or normal operation.

Note: Repeat steps 1 through 2 until the proper VREFCA level is established.

Table 58 - Command Bus Training Steps

Step	1	2	3 (1)	4 (2)
Mode	Normal	CBT	Normal	CBT
Operation Frequency	Low	High	Low	High
FSP-OP	0	1	0	1
FSP-WR	1	1	1	1
Operation	VREFCA Range/Value Setting via MRW	Training Pattern Input then comparison between output Data and expected data.	VREFCA Range/Value Setting via MRW	Training Pattern Input then comparison between output Data and expected data.

2.29.2.1.2. Training Sequence of mode 1 for multi-rank systems

Note that a example shown here is assuming an initial low-frequency operating point, training a high-frequency operating point. The green text is low-frequency, magenta text is high-frequency. Any operating point may be trained from any known good operating point.

1. Set MR13 OP[6]=1B to enable writing to Frequency Set Point 'y' (FSP-WR[y]) (or FSP-WR[x], See Note).
2. Write FSP-WR[y] (or FSP-WR[x]) registers for the channel and ranks to set up high frequency operating parameters including VREF(CA) Range and Setting.
3. Read MR0 OP[7] on the channel and ranks to determine which die are terminating, signified by MR0 OP[7]=1B.
4. Issue MRW-1 and MRW-2 commands to enter Command Bus Training mode on the terminating rank.
5. Drive CKE LOW on the terminating rank (or all ranks), and change CK frequency to the high-frequency operating point.
6. Perform Command Bus Training on the terminating rank (CS, and CA).
7. Exit training by driving CKE HIGH, change CK frequency to the low-frequency operating point, and issue MRW-1 and MRW-2 commands to write the trained values to FSP-WR[y] (or FSP-WR[x]). When CKE is driven HIGH, the SDRAM will automatically switch back to the FSP-OP registers that were in use prior to training.
8. Issue MRW-1 and MRW-2 command to enter training mode on the non-terminating rank (but keep CKE HIGH)
9. Issue MRW-1 and MRW-2 commands to switch the terminating rank to FSP-OP[y] (or FSP-OP[x]), to turn on termination, and change CK frequency to the high frequency operating point.
10. Drive CKE LOW on the non-terminating (or all) ranks. The non-terminating rank(s) will now be using FSP-OP[y] (or FSP-OP[x]).
11. Perform Command Bus Training on the non-terminating rank (CS, and CA).
12. Issue MRW-1 and MRW-2 commands to switch the terminating rank to FSP-OP[x] (or FSP-OP[y]) to turn off termination.
13. Exit training by driving CKE HIGH on the non-terminating rank, change CK frequency to the low-frequency operating point, and issue MRW-1 and MRW-2 commands. When CKE is driven HIGH, the SDRAM will automatically switch back to the FSP-OP registers that were in use prior to training.
14. Write the trained values to FSP-WR[y] (or FSP-WR[x]) by issuing MRW-1 and MRW-2 commands to the SDRAM and setting all applicable mode register parameters.
15. Issue MRW-1 and MRW-2 commands to switch the terminating rank to FSP-OP[y] (or FSP-OP[x]), to turn on termination, and change CK frequency to the high frequency operating point. At this point the Command Bus is trained for both ranks and you may proceed to other training or normal operation.

2.29.2.1.3. Relation between CA input pin DQ output pin for mode 1

The relation between CA input pin DQ output pin is shown in Table 34.

Table 59 - Mapping of CA Input pin and DQ Output pin

Mapping						
CA Number	CA5	CA4	CA3	CA2	CA1	CA0
DQ Number	DQ5	DQ4	DQ3	DQ2	DQ1	DQ0

2.29.2.1.4. Timing Diagram for mode 1

The basic Timing diagrams of Command Bus Training are shown in following figures.

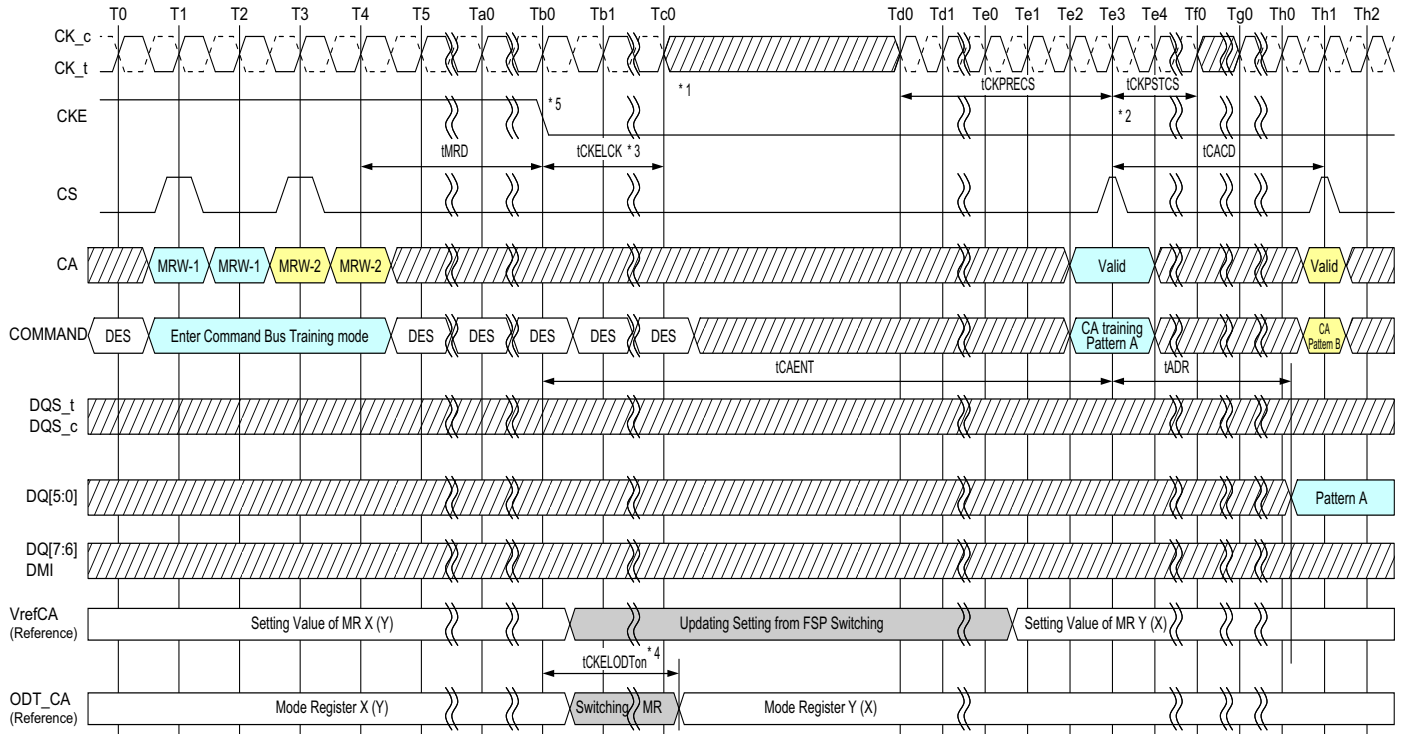

- NOTES :
1. After tCKELCK clock can be stopped or frequency changed any time.
 2. The input clock condition should be satisfied tCKPRECS and tCKPSTCS.
 3. Continue to Drive CK and Hold CA & CS pins low until tCKELCK after CKE is low (which disables command decoding).
 4. When CKE is driven LOW, the SDRAM will switch its FSP-OP registers to use the alternate (i.e. non-active) set. Example: If the SDRAM is currently using FSP-OP[0], then it will switch to FSP-OP[1] when CKE is driven LOW. All operating parameters should be written to the alternate mode registers before entering Command Bus Training to ensure that ODT settings, RL/WL/nWR setting, etc., are set to the correct values. If the alternate FSP-OP has ODT_CA disabled then termination will not enable in CA Bus Training mode. If the ODT_CA pad is bonded to Vss or floating, ODT_CA termination will never enable for that die.
 5. When CKE is driven low in Command Bus Training mode, the LPDDR4-SDRAM will change operation to the alternate FSP, i.e. non-active FSP programmed in the FSP-OP mode register.

Figure 103 - Entering Command Bus Training Mode and CA Training Pattern Input and Output

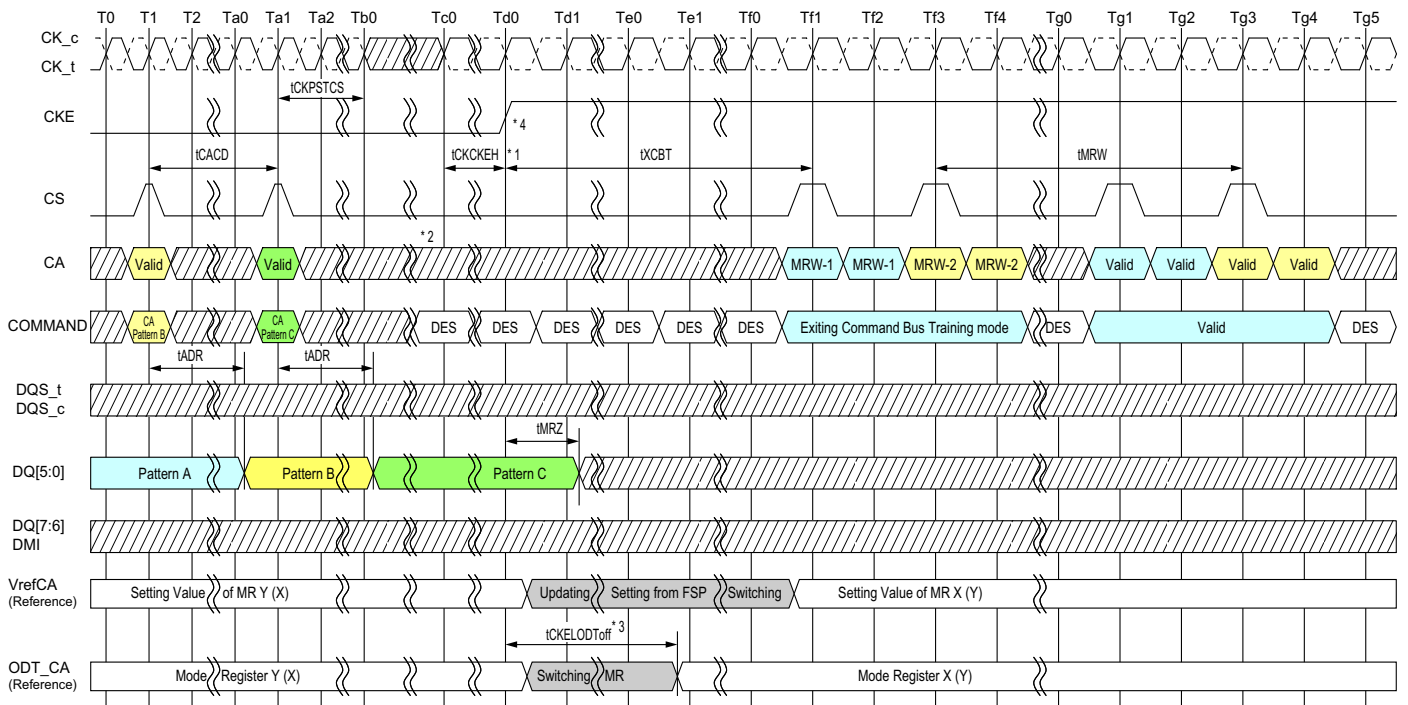

- NOTES : 1. CK must meet tCKCKEH before CKE is driven high.
 When CKE is driven high the clock frequency must be returned to the original frequency (the frequency corresponding to the FSP at which Command Bus Training mode was entered)
2. CS and CA[5:0] must be Deselect (all low) tCKCKEH before CKE is driven high.
3. When CKE is driven high, the SDRAM's ODT_CA will revert to the state/value defined by FSP-OP prior to Command Bus Training mode entry, i.e. the original frequency set point (FSP-OP, MR13-OP[7]).
 Example: If the SDRAM was using FSP-OP[1] for training, then it will switch to FSP-OP[0] when CKE is driven HIGH.
4. When CKE is driven high the LPDDR4-SDRAM will revert to the FSP in operation when Command Bus Training mode was entered.

Figure 104 - Exiting Command Bus Training Mode with Valid Command

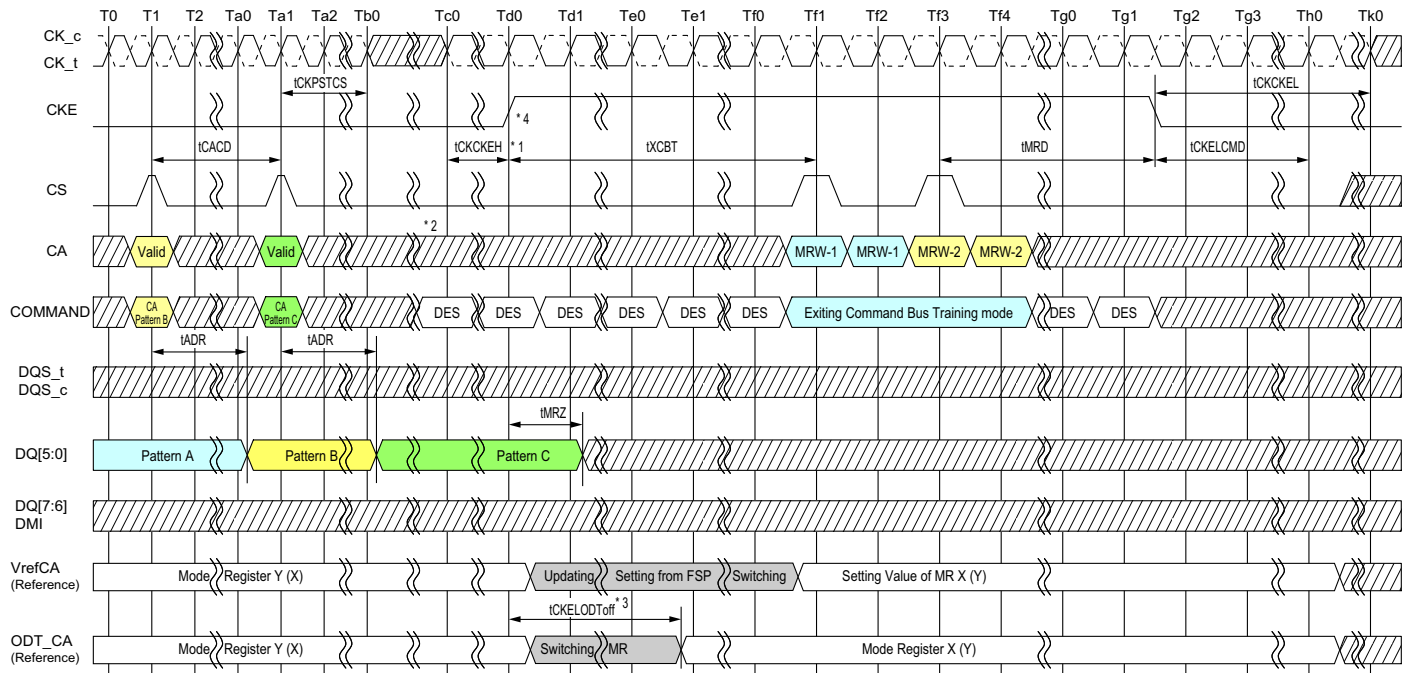

- NOTES : 1. Clock can be stopped or frequency changed any time before tCKCCKEH. CK must meet tCKCCKEH before CKE is driven high. When CKE is driven high the clock frequency must be returned to the original frequency (the frequency corresponding to the FSP at which Command Bus Training mode was entered)
2. CS and CA[5:0] must be Deselect (all low) tCKCCKEH before CKE is driven high.
3. When CKE is driven high, the SDRAM's ODT_CA will revert to the state/value defined by FSP-OP prior to Command Bus Training mode entry, i.e. the original frequency set point (FSP-OP, MR13-OP[7]).
Example: If the SDRAM was using FSP-OP[1] for training, then it will switch to FSP-OP[0] when CKE is driven HIGH.
4. When CKE is driven high the LPDDR4-SDRAM will revert to the FSP in operation when Command Bus Training mode was entered.

Figure 105 - Exiting Command Bus Training Mode with Power Down Entry

2.29.2.1.5. AC Timing

Table 60 - Command Bus Training AC Timing Table for Mode 1

Parameter	Symbol	Min Max	Data Rate							Unit	Note
			533	1066	1600	2133	2667	3200	3733		
Clock and Command Valid after CKE Low	tCKELCK	Min	max(7.5ns, 3nCK)							tCK	
Asynchronous Data Read	tADR	Max	20							ns	
CA Bus Training Command to CA Bus Training Command Delay	tCACD	Min	RU(tADR/tCK)							tCK	1
First CA Bus Training Command Following CKE Low	tCAENT	Min	250							ns	
Valid Clock Requirement before CS High	tCKPRECS	Min	2tck + tXP (tXP = max(7.5ns, 5nCK))							-	
Valid Clock Requirement after CS High	tCKPSTCS	Min	max(7.5ns, 5nCK)							-	
Clock and Command Valid before CKE High	tCKCKEH	Min	2							tCK	
CA Bus Training CKE High to DQ Tri-state	tMRZ	Min	1.5							ns	
ODT turn-on Latency from CKE	tCKELODTon	Min	20							ns	
ODT turn-off Latency from CKE	tCKELODToff	Min	20							ns	
Exit Command Bus Training Mode to next valid command delay	tXCBT_Short	Min	Max(5nCK, 200ns)							-	2
	tXCBT_Middle	Min	Max(5nCK, 200ns)							-	2
	tXCBT_Long	Min	Max(5nCK, 250ns)							-	2

Notes

1. If tCACD is violated, the data for samples which violate tCACD will not be available, except for the last sample (where tCACD after this sample is met). Valid data for the last sample will be available after tADR.
2. Exit Command Bus Training Mode to next valid command delay Time depends on value of VREF(CA) setting: MR12 OP[5:0] and VREF(CA) Range: MR12 OP[6] of FSP-OP 0 and 1. The details are shown in Table. Additionally exit Command Bus Training Mode to next valid command delay Time may affect VREF(DQ) setting. Settling time of VREF(DQ) level is same as VREF(CA) level.

2.29.2.2. Training Mode 2

The LPDDR4-SDRAM uses Frequency Set-Points to enable multiple operating settings for the die. The LPDDR4-SDRAM defaults to FSP-OP[0] at power-up, which has the default settings to operate in uninterminated, low-frequency environments. Prior to training, the mode register settings should be configured by setting MR13 OP[6]=1B (FSP-WR[1]) and setting all other mode register bits for FSP-OP[1] to the desired settings for high-frequency operation. Prior to entering Command Bus Training, the SDRAM will be operating from FSP-OP[x]. Upon Command Bus Training entry when CKE is driven LOW, the LPDDR4-SDRAM will automatically switch to the alternate FSP register set (FSP-OP[y]) and use the alternate register settings during training (See note 6 in Figure X1 for more information on FSP-OP register sets). Upon training exit when CKE is driven HIGH, the LPDDR4-SDRAM will automatically switch back to the original FSP register set (FSP-OP[x]), returning to the “known-good” state that was operating prior to training. The training values for V_{REFCA} are not retained by the DRAM in FSP-OP[y] registers, and must be written to the registers after training exit.

1. To set MR12 OP[7] = 1: CBT Training Mode 2
2. To enter Command Bus Training mode, issue a MRW-1 command followed by a MRW-2 command to set MR13 OP[0]=1B (Command Bus Training Mode Enabled).
3. After time tMRD, CKE may be set LOW, causing the LPDDR4-SDRAM to switch from FSP-OP[x] to FSP-OP[y], and completing the entry into Command Bus Training mode.

A status of DQS_t, DQS_c, DQ and DMI are as follows, and ODT state of DQS_t, DQS_c, DQ and DMI will be followed by MR11 OP[2:0]: DQ ODT and MR13 OP[7]: FSP-OP except when pin is output or transition state.

- DQS_t, DQS_c become input pins for capturing DQ[6:0] levels by its toggling. The ODT for the DQS_t, DQS_C is always enabled during CBT Mode 2. The DQS_t, DQS_c ODT use the value specified by MR11 OP[2:0]: DQ ODT and MR13 OP[7]: FSP-OP.
- DQ[5:0] become input pins for setting V_{REFCA} Level during tDStrain + tDQSICYC + tDHtrain period.
- DQ[5:0] become output pins to feedback its capturing value via command bus by CS signal during tADVW period.
- DQ[6] becomes a input pin for setting V_{REFCA} Range during tDStrain + tDQSICYC + tDHtrain period.
- DQ[6] becomes an output pin during tADVW period and the output data is meaningless.
- DQ[7] becomes an output pin to indicate the meaningful data output by its toggling during tADVW period. The meaningful data is its capturing value via command bus by CS signal. DQ[7] status except tADVW period becomes input or disable, this state is vendor specific, as well as ODT behavior.
- DMI become Input, output or disable, The DMI state is vendor specific.

4. At time tCAENT later, LPDDR4 SDRAM can accept to change its V_{REFCA} Range and Value using input signals of DQS_t, DQS_c and DQ[6:0] from existing value that’s setting via MR12 OP[6:0]. The mapping between MR12 OP code and DQs is shown in Table below. At least one V_{REFCA} setting is required before proceed to next training steps.

Table 61 - Mapping of CA Input pin and DQ output pin

Mapping							
MR12 OP Code	OP6	OP5	OP4	OP3	OP2	OP1	OP0
DQ Number	DQ6	DQ5	DQ4	DQ3	DQ2	DQ1	DQ0

5. The new V_{REFCA} value must “settle” for time tVREF_LONG before attempting to latch CA information.
6. To verify that the receiver has the correct V_{REFCA} setting and to further train the CA eye relative to clock (CK), values latched at the receiver on the CA bus are asynchronously output to the DQ bus.
7. Command followed by the MRW-2 command to set MR13 OP[0]=0B. After time tMRW the LPDDR4-SDRAM is ready for normal operation. After training exit the LPDDR4-SDRAM will automatically switch back to the FSP-OP registers that were in use prior to

training.

Command Bus Training may be executed from IDLE or Self Refresh states. When executing CBT within the Self Refresh state, the SDRAM must not be in a power down state (i.e. CKE must be HIGH prior to training entry). Command Bus Training entry and exit is the same, regardless of the SDRAM state from which CBT is initiated.

2.29.2.2.1. Training Sequence of mode 2 for single-rank systems

Note that an example shown here is assuming an initial low-frequency, non-terminating operating point, training a high-frequency, terminating operating point. **The green text is low-frequency, magenta text is high-frequency.** Any operating point may be trained from any known good operating point. This example is assuming the following condition. Frequency Set Point 'x' for low frequency operation and Frequency Set Point 'y' for High frequency operation.

1. Set MR13 OP[6]=1B to enable writing to Frequency Set Point 'y' (FSP-WR[y]).
2. Write FSP-WR[y] registers for the channel to set up high-frequency operating parameters.
3. Issue MRW-1 and MRW-2 commands to enter Command Bus Training mode.
4. Drive CKE LOW, then change CK frequency to the high-frequency operating point.
5. Perform Command Bus Training (V_{REFCA} , CS, and CA).
6. Exit training, a change CK frequency to the low-frequency operating point prior to driving CKE HIGH, then issue MRW-1 and MRW-2 commands to exit Command Bus Training mode. When CKE is driven HIGH, the SDRAM will automatically switch back to the FSP-OP registers that were in use prior to training (i.e. trained values are not retained by the SDRAM).
7. Write the trained values to FSP-WR[y] by issuing MRW-1 and MRW-2 commands to the SDRAM and setting all applicable mode register parameters.
8. Issue MRW-1 and MRW-2 commands to switch to FSP-OP[y] to turn on termination, and change CK frequency to the high frequency operating point. At this point the Command Bus is trained and you may proceed to other training or normal operation.

2.29.2.2.2. Training Sequence of mode 2 for multi-rank systems

Note that an example shown here is assuming an initial low-frequency operating point, training a high-frequency operating point. **The green text is low-frequency, magenta text is high-frequency.** Any operating point may be trained from any known good operating point. This example is assuming the following condition. Frequency Set Point 'x' for low frequency operation and Frequency Set Point 'y' for High frequency operation.

1. Set MR13 OP[6]=1B to enable writing to Frequency Set Point 'y' (FSP-WR[y]).
2. Write FSP-WR[y] registers for the channel and ranks to set up high frequency operating parameters .
3. Read MR0 OP[7] on the channel and ranks to determine which die are terminating, signified by MR0 OP[7]=1B.
4. Issue MRW-1 and MRW-2 commands to enter Command Bus Training mode on the terminating rank.
5. Drive CKE LOW on the terminating rank (or all ranks), and change CK frequency to the high frequency operating point.
6. Perform Command Bus Training on the terminating rank (V_{REFCA} , CS, and CA).
7. Exit training by driving CKE HIGH, change CK frequency to the low-frequency operating point, and issue MRW-1 and MRW-2 commands to exit Command Bus Training mode. When CKE is driven HIGH, the SDRAM will automatically switch back to the FSP-OP registers that were in use prior to training (i.e. trained values are not retained by the SDRAM).
8. Write the trained values to FSP-WR[y] by issuing MRW-1 and MRW-2 commands to the SDRAM and setting all applicable mode

register parameters.

9. Issue MRW-1 and MRW-2 command to enter training mode on the non-terminating rank (but keep CKE HIGH).
10. Issue MRW-1 and MRW-2 commands to switch the terminating rank to FSP-OP[y], to turn on termination, and change CK frequency to the high frequency operating point.
11. Drive CKE LOW on the non-terminating (or all) ranks. The non-terminating rank(s) will now be using FSP-OP[y].
12. Perform Command Bus Training on the non-terminating rank (V_{REFCA} , CS, and CA).
13. Issue MRW-1 and MRW-2 commands to switch the terminating rank to FSP-OP[x] to turn off termination.
14. Exit training by driving CKE HIGH on the non-terminating rank, change CK frequency to the low frequency operating point, and issue MRW-1 and MRW-2 commands to exit Command Bus Training mode. When CKE is driven HIGH, the SDRAM will automatically switch back to the FSP-OP registers that were in use prior to training (i.e. trained values are not retained by the SDRAM).
15. Write the trained values to FSP-WR[y] by issuing MRW-1 and MRW-2 commands to the SDRAM and setting all applicable mode register parameters.
16. Issue MRW-1 and MRW-2 commands to switch the terminating rank to FSP-OP[y], to turn on termination, and change CK frequency to the high frequency operating point. At this point the Command Bus is trained for both ranks and you may proceed to other training or normal operation.

2.29.2.2.3. Relation between CA input pin DQ output pin for mode 2

The relation between CA input pin DQ output pin is shown in Table below.

Table 62 - Mapping of CA Input pin and DQ Output pin

Mapping						
CA Number	CA5	CA4	CA3	CA2	CA1	CA0
DQ Number	DQ5	DQ4	DQ3	DQ2	DQ1	DQ0

2.29.2.2.4. Timing Diagram for mode 2

The basic Timing diagrams of Command Bus Training are shown in following figures.

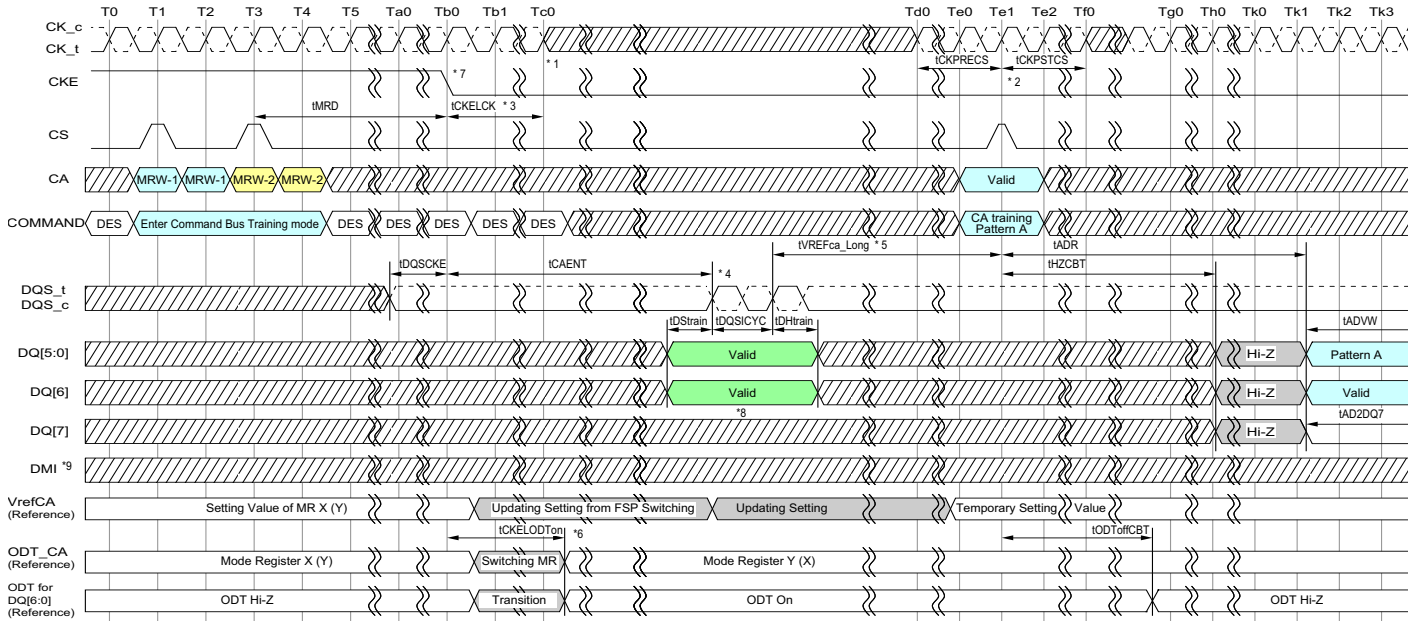

- NOTES :
1. After tCKELCK clock can be stopped or frequency changed any time.
 2. The input clock condition should be satisfied tCKPRECS and tCKPSTCS.
 3. Continue to Drive CK and Hold CS pins low until tCKELCK after CKE is low (which disables command decoding).
 4. The DRAM may or may not capture the first rising/falling edge of DQS_{i/c} due to an unstable first rising edge. At least 2 consecutive pulses of DQS signal input are required for every DQS input signal when capturing DQ[6:0] signals. The captured value of the DQ[6:0] signal level by each DQS edge is overwritten at any time. The DRAM updates its VREFca setting of MR12 temporary, after time tVREFca_Long.
 5. tVREFca_Long may be reduced to tVREFca_Middle or tVREFca_Short. See Table XX for detail.
 6. When CKE is driven LOW, the SDRAM will switch its FSP-OP registers to use the alternate (i.e. non-active) set. Example: If the SDRAM is currently using FSP-OP[0], then it will switch to FSP-OP[1] when CKE is driven LOW. All operating parameters should be written to the alternate mode registers before entering Command Bus Training to ensure that ODT settings, RL/WL/nWR setting, etc., are set to the correct values. If the alternate FSP-OP has ODT_CA disabled then termination will not enable in CA Bus Training mode. If the ODT_CA pad is bonded to Vss, ODT_CA termination will never enable for that die.
 7. When CKE is driven low in Command Bus Training mode, the LPDDR4-SDRAM will change operation to the alternate FSP, i.e. non-active FSP programmed in the FSP-OP mode register.
 8. tDStrain + tDQSCYC + tDHtrain period on DQ7 become Input or disable, this state during CBT Mode 2 is vendor specific.
 9. DMI become Input, output or disable. The DMI state during CBT Mode 2 is vendor specific.

Figure 106 - Entering Command Bus Training Mode and CA Training Pattern Input with VrefCA Value Update

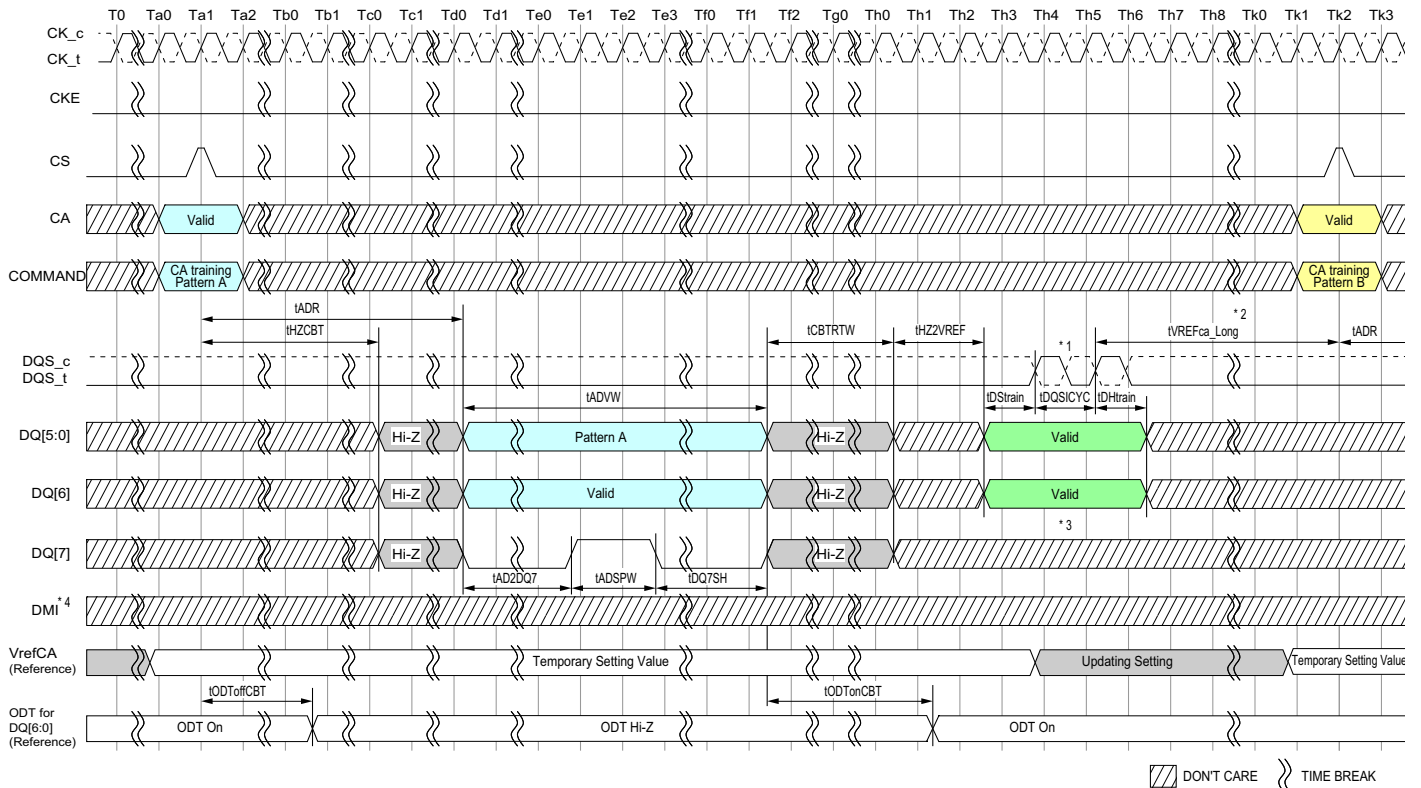

- NOTES :
1. The DRAM may or may not capture the first rising/falling edge of DQS_{t/c} due to an unstable first rising edge. At least 2 consecutive pulses of DQS signal input are required for every DQS input signal when capturing DQ[6:0] signals. The captured value of the DQ[6:0] signal level by each DQS edge is overwritten at any time. The DRAM updates its VREFca setting of MR12 temporary, after time tVREFca_Long.
 2. tVREFca_Long may be reduced to tVREFca_Middle or tVREFca_Short. See Table XX for detail.
 3. tDStrain + tDQSCYC + tDHtrain period on DQ7 become Input or disable, this state during CBT Mode 2 is vendor specific.
 4. DMI become Input, output or disable, The DMI state during CBT Mode 2 is vendor specific.

Figure 107 - CA pattern Input/Output to Vref setting Input

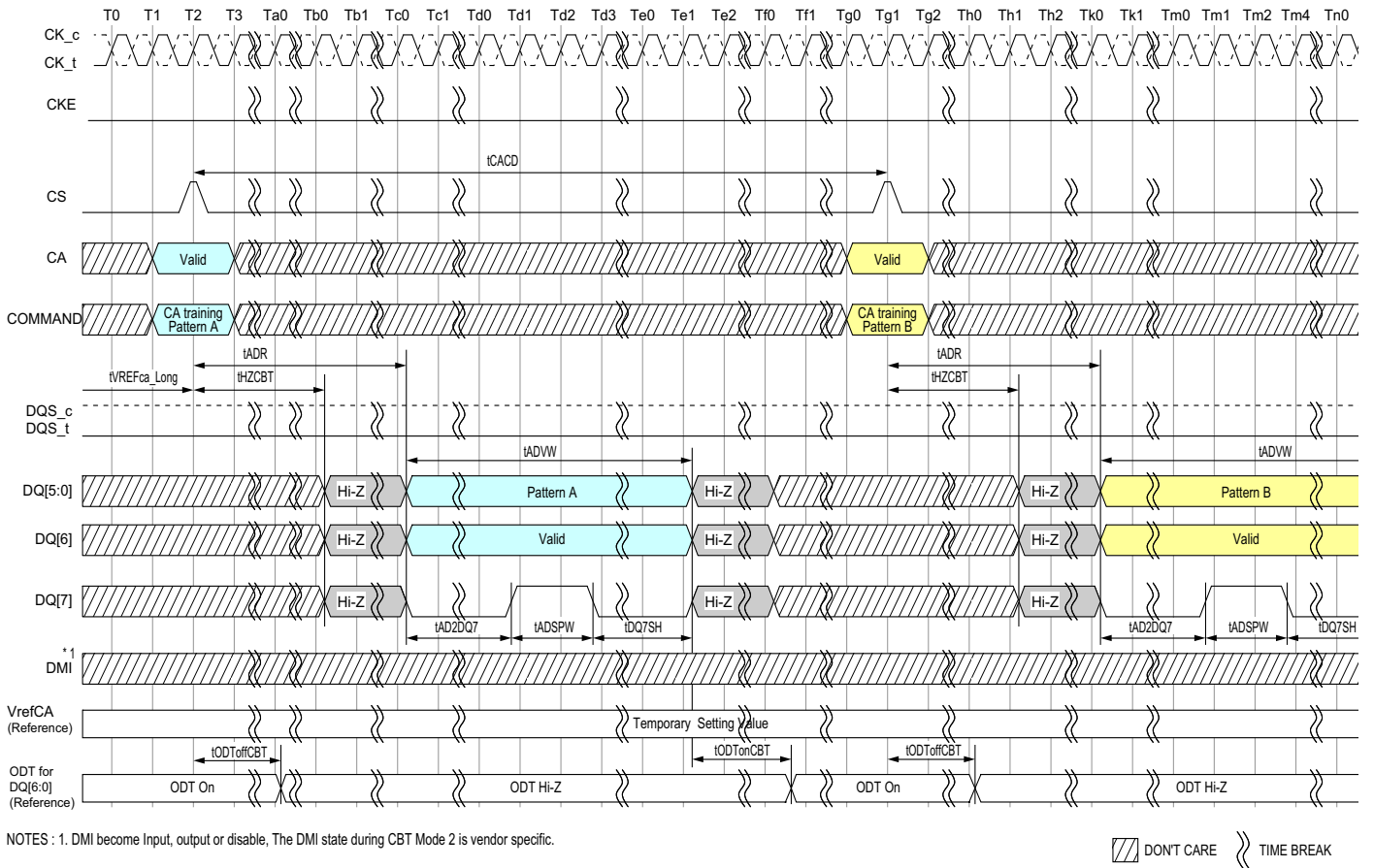
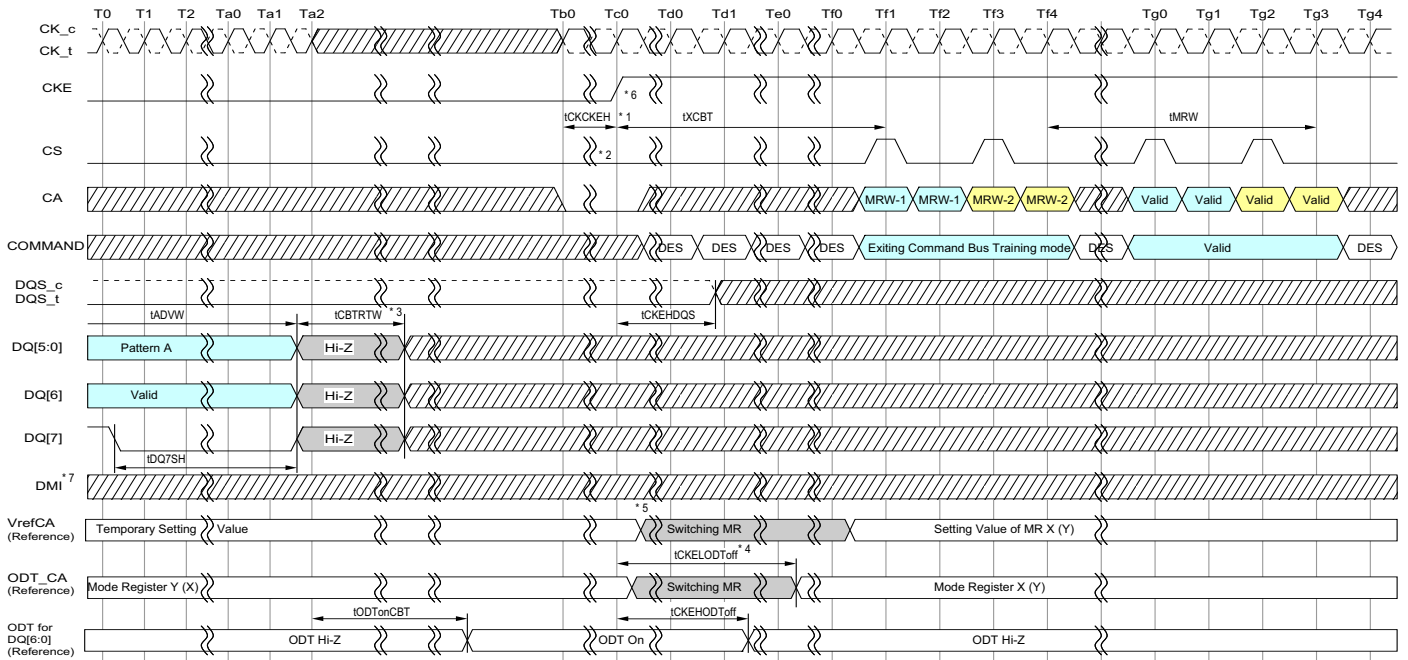
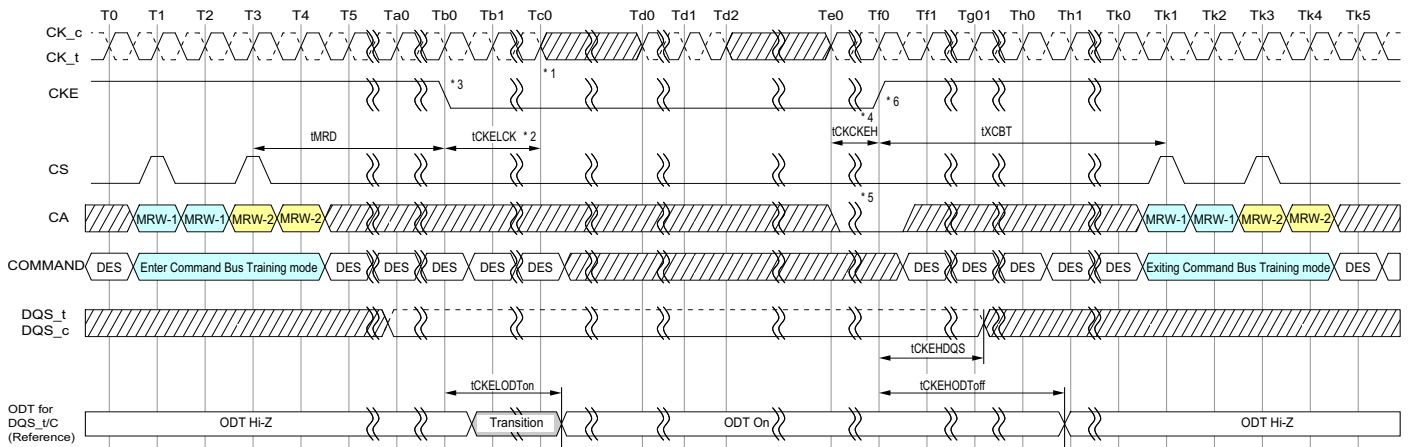

Figure 108 - Consecutive CA training pattern Input/Output



- NOTES : 1. CK must meet tCKCKEH before CKE is driven high.
 When CKE is driven high the clock frequency must be returned to the original frequency (the frequency corresponding to the FSP at which Command Bus Training mode was entered)
2. CS and CA[5:0] must be all low tCKCKEH before CKE is driven high.
3. CKE must be held low from when CS transitions high to when tCBTRTW is satisfied. Exiting CBT mode is prohibited during this period.
4. When CKE is driven high, the SDRAM's ODT_CA will revert to the state/value defined by FSP-OP prior to Command Bus Training mode entry, i.e. the original frequency set point (FSP-OP, MR13-OP[7]).
 Example: If the SDRAM was using FSP-OP[1] for training, then it will switch to FSP-OP[0] when CKE is driven HIGH.
5. Training values are not retained by the SDRAM, and must be written to the FSP-OP register set before returning to operation at the trained frequency. Example: VREF(ca) will return to the value programmed in the original set point.
6. When CKE is driven high the LPDDR4-SDRAM will revert to the FSP in operation when Command Bus Training mode was entered.
7. DMI become Input, output or disable, The DMI state during CBT Mode 2 is vendor specific.

Figure 109 - Exiting Command Bus Training Mode



- NOTES : 1. After tCKELCK clock can be stopped or frequency changed any time.
2. Continue to Drive CK and Hold CS pins low until tCKELCK after CKE is low (which disables command decoding).
3. When CKE is driven low in Command Bus Training mode, the LPDDR4-SDRAM will change operation to the alternate FSP, i.e. non-active FSP programmed in the FSP-OP mode register.
4. CK must meet tCKCKEH before CKE is driven high.
 When CKE is driven high the clock frequency must be returned to the original frequency (the frequency corresponding to the FSP at which Command Bus Training mode was entered)
5. CS and CA[5:0] must be all high tCKCKEH before CKE is driven high.
6. When CKE is driven high the LPDDR4-SDRAM will revert to the FSP in operation when Command Bus Training mode was entered.

Figure 110 - DQS ODT Timing during Command Bus Training Mode 2

2.29.2.2.5. AC Timing
Table 63 - Command Bus Training AC Timing Table for Mode 2

Parameter	Symbol	Min Max	Data Rate						Unit	Note
			533	1066	1600	2133	2667	3200		
Command Bus Training Timing										
Valid Clock Requirement after CKE Input low	tCKELCK	Min	Max(5ns,5nCK)						ns	
Valid Clock Requirement before CS High	tCKPRECS	Min	2tCK + tXP (tXP = max(7.5ns, 5nCK))						-	
Valid Clock Requirement after CS High	tCKPSTCS	Min	max(7.5ns, 5nCK))						-	
Valid Strobe Requirement before CKE Low	tDQSCKE	Min	10						ns	1
First CA Bus Training Command Following CKE Low	tCAENT	Min	250						ns	
VREF Step Time - Long	tVREFCA_Long	Max	250						ns	2
VREF Step Time - Middle	tVREFCA_Middle	Max	200						ns	3
VREF Step Time - Short	tVREFCA_Short	Max	100						ns	4
Data Setup for Vref Training Mode	tDStrain	Min	2						ns	
Data Hold for Vref Training Mode	tDHtrain	Min	2						ns	
Asynchronous Data Read Valid Window	tADVW	Min	16						ns	
		Max	80						ns	
DQS Input period at CBT mode	tDQSICYC	Min	5						ns	
		Max	100						ns	
Asynchronous Data Read	tADR	Max	20						ns	
DQS_c high impedance time from CS High	tHZCBT	Min	0						ns	
Asynchronous Data Read to DQ7 toggle	tAD2DQ7	Min	3						ns	
		Max	10						ns	
DQ7sample hold time	tDQ7SH	Min	10						ns	
		Max	60						ns	
Asynchronous Data Read Pulse Width	tADSPW	Min	3						ns	
		Max	10						ns	
Hi-Z to asynchronous VrefCA valid data	tHZ2VREF	Min	Max(10ns, 5nCK)						-	
Read to Write Delay at CBT mode	tCBTRTW	Min	2						ns	
CA Bus Training Command to CA Bus Training Command Delay	tCACD	Min	Max(110ns, 4nCK)						-	
Command Bus Training Timing										

Parameter	Symbol	Min Max	Data Rate							Unit	Note
			533	1066	1600	2133	2667	3200	3733		
Minimum delay from CKE High to Strobe High Impedance	tCKEHDQS	Min	10							ns	
Clock and Command Valid before CKE High	tCKCKEH	Min	Max(1.75ns,3nCK)							-	
ODT turn-on Latency from CKE	tCKELODTon	Min Max	20							ns	
ODT turn-off Latency from CKE for ODT_CA	tCKELODToff	Min Max	20							ns	
ODT turn-off Latency from CKE for ODT_DQ and DQS	tCKEHODTOff	Min Max	20							ns	
ODT_DQ turn-off Latency from CS high during CB Training	tODTOffCBT	Max	20							ns	
ODT_DQ turn-on Latency from the end of Valid Data out	tODTonCBT	Max	Max(10ns, 5nCK)							-	
Exit Command Bus Training Mode to next valid command delay	tXCBT_Short	Min	Max(5nCK, 200ns)							-	5
	tXCBT_Middle	Min	Max(5nCK, 200ns)							-	5
	tXCBT_Long	Min	Max(5nCK, 250ns)							-	5

Notes

- DQS_t has to retain a low level during tDQSCKE period, as well as DQS_c has to retain a high level.
- VREFCA_Long is the time including up to VREFmin to VREFmax or VREFmax to VREFmin change across the VREFDQ Range in VREF voltage.
- VREF_Middle is at least 2 stepsizes increment/decrement change within the same VREFDQ range in VREF voltage.
- VREF_Short is for a single stepsize increment/decrement change in VREF voltage.
- Exit Command Bus Training Mode to next valid command delay Time depends on value of VREF(CA) setting: MR12 OP[5:0] and VREF(CA) Range: MR12 OP[6] of FSP-OP 0 and 1. The details are shown in Table 61.
Additionally exit Command Bus Training Mode to next valid command delay Time may affect VREF(DQ) setting. Settling time of VREF(DQ) level is same as VREF(CA) level.

2.30. Frequency Set Point (FSP)

Frequency Set-Points allow the LPDDR4-SDRAM CA Bus to be switched between two differing operating frequencies, with changes in voltage swings and termination values, without ever being in an un-trained state which could result in a loss of communication to the DRAM. This is accomplished by duplicating all CA Bus mode register parameters, as well as other mode register parameters commonly changed with operating frequency. These duplicated registers form two sets that use the same mode register addresses, with read/write access controlled by MR bit FSP-WR (Frequency Set-Point Write/Read) and the DRAM operating point controlled by another MR bit FSP-OP (Frequency Set-Point Operation). Changing the FSP-WR bit allows MR parameters to be changed for an alternate Frequency Set-Point without affecting the LPDDR4-SDRAM's current operation. Once all necessary parameters have been written to the alternate Set-Point, changing the FSP-OP bit will switch operation to use all of the new parameters simultaneously (within tFC), eliminating the possibility of a loss of communication that could be caused by a partial configuration change.

Parameters which have two physical registers controlled by FSP-WR and FSP-OP include:

Table 64 - Mode Register Function with two physical registers

MR#	Operand	Function	Note
MR1	OP[2]	WR-PRE (WR Pre-amble Length)	1
	OP[3]	RD-PRE (RD Pre-amble Type)	
	OP[6:4]	nWR (Write-Recovery for Auto-Precharge commands)	
	OP[7]	PST (RD Post-Ambles Length)	
MR2	OP[2:0]	RL (Read latency)	
	OP[5:3]	WL (Write latency)	
	OP[6]	WLS (Write Latency Set)	
MR3	OP[0]	PU-Cal (Pull-up Calibration Point)	
	OP[1]	WR PST(WR Post-Ambles Length)	
	OP[5:3]	PDDS (Pull-Down Drive Strength)	
	OP[6]	DBI-RD (DBI-Read Enable)	
	OP[7]	DBI-WR (DBI-Write Enable)	
MR11	OP[2:0]	DQ ODT (DQ Bus Receiver On-Die-Termination)	
	OP[6:4]	CA ODT (CA Bus Receiver On-Die-Termination)	
MR12	OP[5:0]	VREF(CA) (VREF(CA) Setting)	
	OP[6]	VR-CA (VREF(CA) Range)	
MR14	OP[5:0]	VREF(dq) (VREF(dq) Setting)	
	OP[6]	VR(dq) (VREF(dq) Range)	
MR22	OP[2:0]	SoC ODT (Controller ODT Value for VOH calibration)	
	OP[3]	ODTE-CK (CK ODT enabled for non terminating rank)	
	OP[4]	ODTE-CS (CS ODT enable for non-terminating rank)	
	OP[5]	ODTD-CA (CA ODT termination disable)	

Notes

1. Supporting the two physical registers for Burst Length: MR1 OP[1:0] is optional.

Applications requiring support of both vendor options shall assure that both FSP-OP[0] and FSP-OP[1] are set to the same code. Refer to vendor datasheets for detail.

See Mode Register Definition for more details.

Following table shows how the two mode registers for each of the parameters above can be modified by setting the appropriate FSP-WR value, and how device operation can be switched between operating points by setting the appropriate FSP-OP value. The FSP-WR and FSP-OP functions operate completely independently.

Function	MR# & Operand	Data	Operation	Note
FSP-WR	MR13 OP[6]	0 (Default)	Data write to Mode Register N for FSP-OP[0] by MRW Command. Data read from Mode Register N for FSP-OP[0] by MRR Command.	1
		1	Data write to Mode Register N for FSP-OP[1] by MRW Command. Data read from Mode Register N for FSP-OP[1] by MRR Command.	
FSP-OP	MR13 OP[7]	0 (Default)	DRAM operates with Mode Register N for FSP-OP[0] setting.	2
		1	DRAM operates with Mode Register N for FSP-OP[1] setting.	

Notes

1. FSP-WR stands for Frequency Set Point Write/Read.
2. FSP-OP stands for Frequency Set Point Operating Point.

2.30.1. Frequency Set Point update timing

The Frequency set point update timing is shown in the timing diagram below. When changing the frequency set point via MR13 OP[7], the VRCG setting: MR13 OP[3] have to be changed into VREF Fast Response (high current) mode at the same time. After Frequency change time(t_{FC}) is satisfied. VRCG can be changed into Normal Operation mode via MR13 OP[3].

Figure 111 - Frequency Set Point Switching Timing

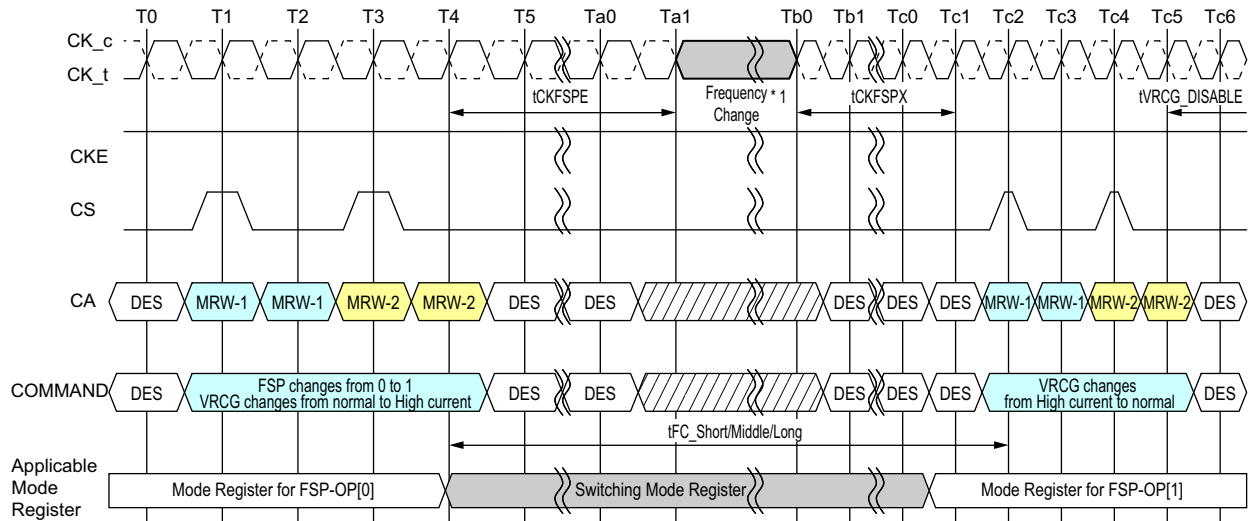

NOTES : 1. The definition that is Clock frequency change during CKE HIGH should be followed at the frequency change operation. For more information, refer to Section 4.42 Input Clock Stop and Frequency Change.



 DON'T CARE  TIME BREAK

Table 65 - Frequency Set Point AC timing

Parameter	Symbol	min max	533	1066	1600	2133	2667	3200	3733	4266	Unit	Note
Frequency Set Point Switching Time	tFC_Short	min	200								ns	1
	tFC_Middle	min	200								ns	1
	tFC_Long	min	250								ns	1
Valid Clock Requirement after entering FSP change	tCKFSPE	min	max(7.5ns, 4nCK)								-	
Valid Clock Requirement before 1st valid command after FSP change	tCKFSPX	min	max(7.5ns, 4nCK)								-	

Notes

1. Frequency Set Point Switching Time depends on value of VREF(CA) setting: MR12 OP[5:0] and VREF(CA) Range: MR12 OP[6] of FSP-OP 0 and 1. The details are shown in Table "tFC value mapping". Additionally change of Frequency Set Point may affect VREF(DQ) setting. Setting time of VREF(DQ) level is same as VREF(CA) level.

Table 66 - tFC value mapping

Application	Step size		Range	
	From FSP-OP0	To FSP-OP1	From FSP-OP0	To FSP-OP1
tFC_Short	Base	A single step increment/decrement	Base	No Change
tFC_Middle	Base	Two or more steps increment/decrement	Base	No Change
tFC_Long	-	-	Base	Change

Notes

1. As well as from FSP-OP1 to FSP-OP0

Table 67 - tFC value mapping example

Case	From/To	FSP-OP MR13 OP[7]	VREF(CA) setting: MR12: OP[5:0]	VREF(CA) Range: MR12 OP[6]	Application	Note
1	From	0	001100	0	tFC_Short	1
	To	1	001101	0		
2	From	0	001100	0	tFC_Middle	2
	To	1	001110	0		
3	From	0	Don't care	0	tFC_Long	3
	To	1	Don't care	1		

Notes

1. A single step size increment/decrement for VREF(CA) Setting Value.
2. Two or more step size increment/decrement for VREF(CA) Setting Value.
3. VREF(CA) Range is changed. In tis case changing VREF(CA) Setting doesn't affect tFC value.

The LPDDR4-SDRAM defaults to FSP-OP[0] at power-up. Both Set-Points default to settings needed to operate in un-terminated, low-frequency environments. To enable the LPDDR4-SDRAM to operate at higher frequencies, Command Bus Training mode should be utilized to train the alternate Frequency Set-Point (Figure "Training Two Frequency Set Points"). See the section Command Bus Training for more details on this training mode.

Figure 112 - Training Two Frequency Set Points

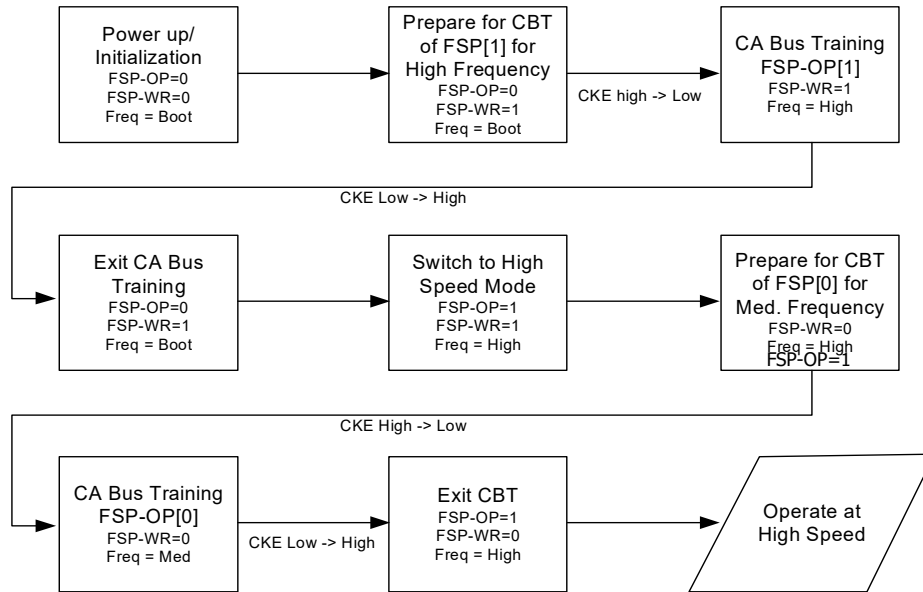

Once both Frequency Set Points have been trained, switching between points can be performed by a single MRW followed by waiting for tFC (figure below)

Figure 113 - Switching between two trained Frequency Set Points

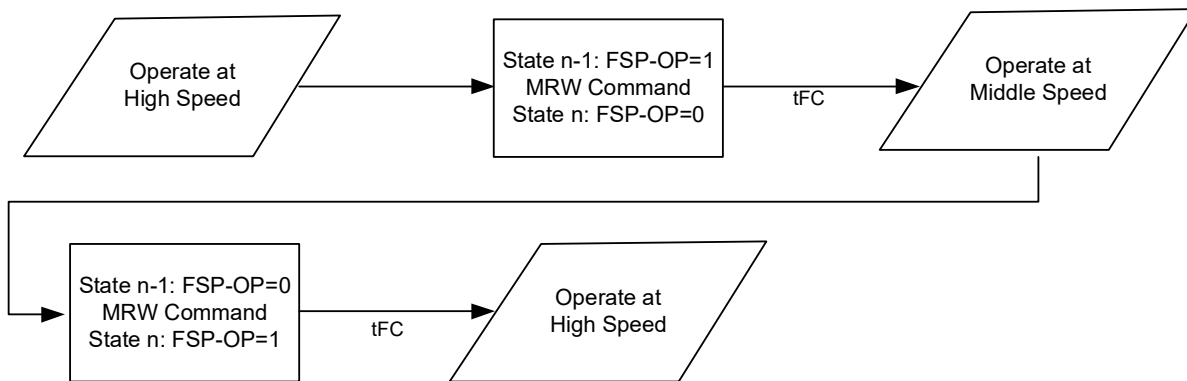

Switching to a third (or more) Set-Point can be accomplished if the memory controller has stored the previously-trained values (in particular the Vref-CA calibration value) and re-writes these to the alternate Set-Point before switching FSP-OP (Figure below).

Figure 114 - Switching to a third trained Frequency Set Point

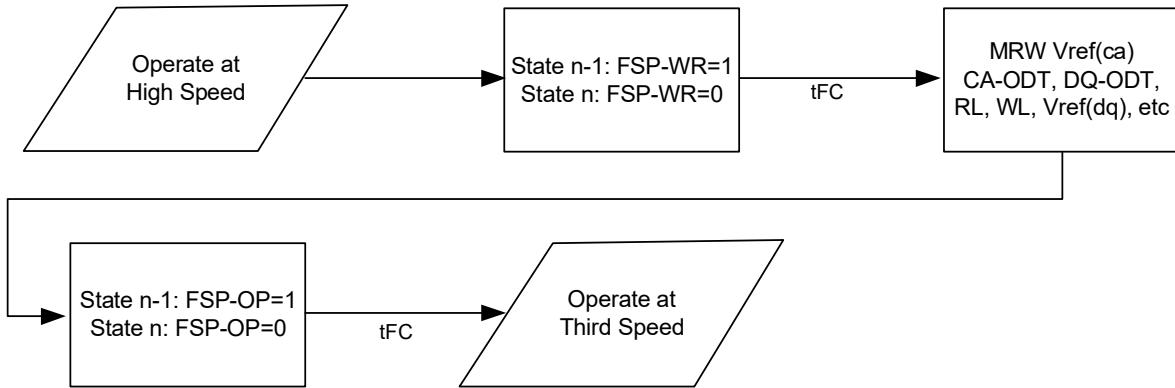

2.31. Mode Register Write-WR Leveling Mode

To improve signal-integrity performance, the LPDDR4 SDRAM provides a write-leveling feature to compensate CK-to-DQS timing skew affecting timing parameters such as tDQSS, tDSS, and tDSH. The DRAM samples the clock state with the rising edge of DQS signals, and asynchronously feeds back to the memory controller. The memory controller references this feedback to adjust the clock-to-data strobe signal relationship for each DQS_t/DQS_c signal pair.

All data bits (DQ[7:0] for DQS_t/DQS_c[0], and DQ[15:8] for DQS_t/DQS_c[1]) carry the training feedback to the controller. Both DQS signals in each channel must be leveled independently.

The LPDDR4 SDRAM enters into write-leveling mode when mode register MR2-OP[7] is set HIGH. When entering write-leveling mode, the state of the DQ pins is undefined. During write-leveling mode, only DESELECT commands are allowed, or a MRW command to exit the write-leveling operation. Depending on the absolute values of tQSL and tQSH in the application, the value of tDQSS may have to be better than the limits provided in the chapter “AC Timing Parameters” in order to satisfy the tDSS and tDSH specification. Upon completion of the write-leveling operation, the DRAM exits from write-leveling mode when MR2-OP[7] is reset LOW.

Write Leveling should be performed before Write Training (DQS2DQ Training).

Note 1 As of publication of this document, under discussion by the formulating committee.

2.31.1. Write Leveling Procedure

1. Enter into Write-leveling mode by setting MR2-OP[7]=1,
2. Once entered into Write-leveling mode, DQS_t must be driven LOW and DQS_c HIGH after a delay of tWLDQSEN.
3. Wait for a time tWLMRD before providing the first DQS signal input. The delay time tWLMRD(MAX) is controller-dependent.
4. DRAM may or may not capture first rising edge of DQS_t due to an unstable first risign edge. Hence provide at least consecutive 2 pulses of DQS signal input is required in every DQS input signal during Write Training Mode.
The captured clock level by each DQS edges are overwritten at any time and the DRAM provides asynchronous feedback on all the DQ bits after time tWLO.
5. The feedback provided by the DRAM is referenced by the controller to increment or decrement the DQS_t and/or DQS_c delay settings.
6. Repeat step 4 through step 5 until the proper DQS_t/DQS_c delay is established.
7. Exit from Write-leveling mode by setting MR2-OP[7]=0.

A Write Leveling timing example is shown in figure below.

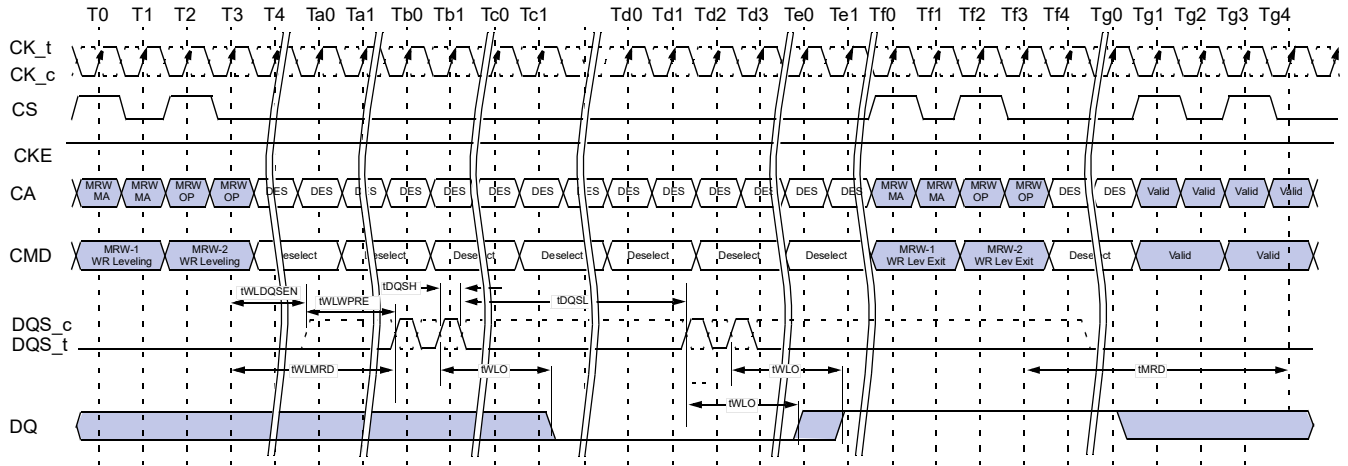

Figure 115 - Write Leveling Timing, tDQSL(max)

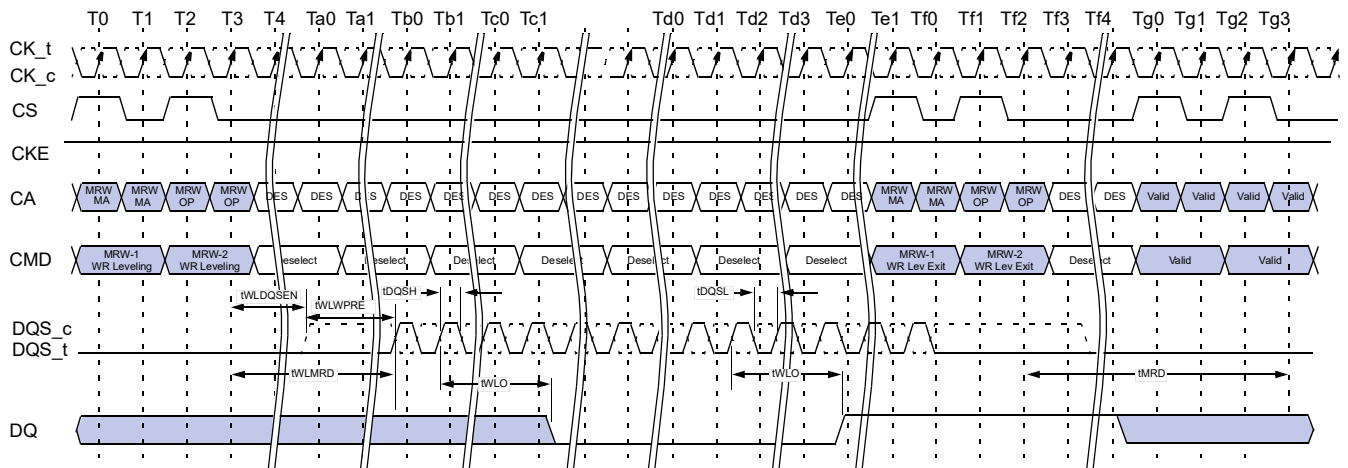
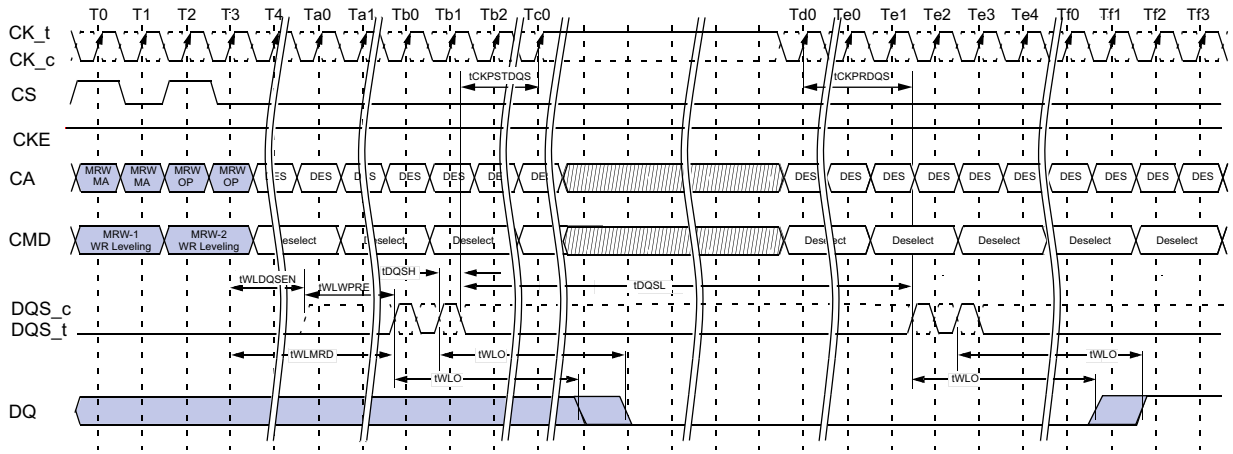

Figure 116 - Write Leveling Timing, tDQSL(min)

2.31.2. Input Clock Frequency Stop and Change

The input clock frequency can be stopped or changed from one stable clock rate to another stable clock rate during Write Leveling mode.

The Frequency stop or change timing is shown in Figure below



NOTES : 1. CK_t is held LOW and CK_c is held HIGH during clock stop.
 2. CS shall be held LOW during clock stop

Figure 117 - Clock Stop and Timing during Write Leveling

Table 68 - Write Leveling Timing Parameters

Parameter	Symbol	min max	533	1066	1600	2133	2667	3200	3733	4266	Unit	Note
DQS _t /DQS _c delay after write leveling mode is programmed	tWLDQSEN	min					20				tCK	
Write preamble for Write Leveling	tWLWPRE	min					20				tCK	
First DQS _t /DQS _c edge after write leveling mode is programmed	tWLMRD	min					40				tCK	
Write leveling output delay	tWLO	min					0				ns	
		max					20					
Mode register set command delay	tMRD	min					max(14ns, 10nCK)			ns		
Valid Clock Requirement before DQS Toggle	tCKPRDQS	min					max(7.5ns, 4nCK)			-		
Valid Clock Requirement after DQS Toggle	tCKPSTDQS	min					max(7.5ns, 4nCK)			-		

2.31.3. Write Leveling Setup and Hold Time

Table 69 - Write Leveling Setup and Hold Time

Parameter	Symbol	min max	533	1066	1600	2133	2667	3200	3733	4266	Unit
Write leveling hold time	tWLH	min	150	150	150	100	100	75	75	50	ps
Write leveling setup time	tWLS	min	150	150	150	100	100	75	75	50	ps
Write leveling invalid window	tWLIVW	min	240	240	240	160	160	120	120	90	ps

Notes

1. In addition to the traditional setup and hold time specifications above, there is value in a input valid window based specification for write-leveling training. As the training is based on each device, worst case process skews for setup and hold do not make sense to close timing between CK and DQS.
2. tWLIVW is defined in a similar manner to tdlVW_Total, except that here it is a DQS input valid window with respect to CK. This would need to account for all VT (voltage and temperature) drift terms between CK and DQS within the DRAM that affect the write-leveling input valid window.

The DQS input mask for timing with respect to CK is shown in the following figure. The “total” mask (TdiVW_total) defines the time the input signal must not encroach in order for the DQS input to be successfully captured by CK with a BER of lower than tbd. The mask is a receiver property and it is not the valid data-eye.

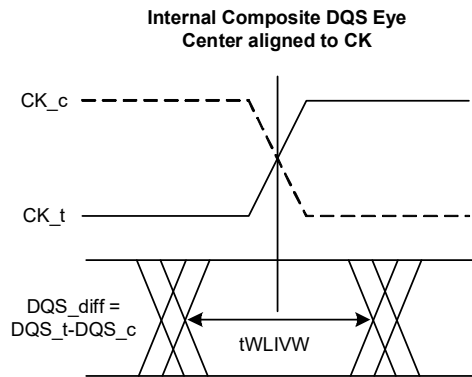

Figure 118 - DQS_t/DQS_c and CK_t/CK_c at DRAM Latch

2.32. RD DQ Calibration

2.32.1. RD DQ Calibration for Byte (x8) mode

LPDDR4 devices feature a RD DQ Calibration training function that outputs a 8-bit user-defined pattern on the DQ pins. RD DQ Calibration is initiated by issuing a MPC-1 [RD DQ Calibration] command followed by a CAS-2 command, cause the LPDDR4-SDRAM to drive the contents of MR32 followed by the contents of MR40 on each of DQ[7:0] and DMI[0]. The pattern can be inverted on selected DQ pins according to user-defined invert masks written to MR15 and MR20.

2.32.1.1. RD DQ Calibration Training Procedure

The procedure for executing RD DQ Calibration is:

Issue MRW commands to write MR32 (first eight bits), MR40 (second eight bits), MR15 (eight-bit invert mask for byte 0 : DQ[7:0]) and MR20 (eight-bit invert mask for byte 1 : DQ[15:8])

- Optionally this step could be skipped to use the default patterns
 - MR32 default = 5Ah
 - MR40 default = 3Ch
 - MR15 default = 55h
 - MR20 default = 55h
- Issue an MPC-1 [RD DQ Calibration] command followed immediately by a CAS-2 command
- Each time an MPC-1 [RD DQ Calibration] command followed by a CAS-2 is received by the LPDDR4 SDRAM, a 16-bit data burst will, after the currently set RL, drive the eight bits programmed in MR32 followed by the eight bits programmed in MR40 on all I/O pins.
- The data pattern will be inverted for I/O pins with a '1' programmed in the corresponding invert mask mode register bit.
- Note that the pattern is driven on the DMI pins, but no data bus inversion function is enabled, even if Read DBI is enabled in the DRAM mode register.
- This command can be issued every tCCD seamlessly, and can be issued seamlessly with array Read commands.
- The operands received with the CAS-2 command must be driven LOW.
- DQ Read Training can be performed with any or no banks active, during Refresh, or during SREF with CKE high.

Table 70 - Invert Mask Assignments

DQ Pin	0	1	2	3	DMIO	4	5	6	7
MR15 bit	0	1	2	3	N/A	4	5	6	7
DQ Pin	8	9	10	11	DMI1	12	13	14	15
MR20 bit	0	1	2	3	N/A	4	5	6	7

2.32.1.2. DQ Read Training Example

An example of DQ Read Training output is shown in Table 2. This shows the 16-bit data pattern that will be driven on each DQ in byte 0 when one DQ Read Training command is executed. This output assumes the following mode register values are used:

- MR32 = 1CH
- MR40 = 59H
- MR15 = 55H
- MR20 = 55H

Table 71 - DQ Read Calibration Bit Ordering and Inversion Example

Pin	Invert	Bit Sequence →															
		15	14	13	12	11	10	9	8	7	6	5	4	3	2	1	0
DQ0 (DQ8)	Yes	1	0	1	0	0	1	1	0	1	1	1	0	0	0	1	1
DQ1 (DQ9)	No	0	1	0	1	1	0	0	1	0	0	0	1	1	1	0	0
DQ2 (DQ10)	Yes	1	0	1	0	0	1	1	0	1	1	1	0	0	0	1	1
DQ3 (DQ11)	No	0	1	0	1	1	0	0	1	0	0	0	1	1	1	0	0
DMI0 (DMI1)	Never	0	1	0	1	1	0	0	1	0	0	0	1	1	1	0	0
DQ4 (DQ12)	Yes	1	0	1	0	0	1	1	0	1	1	1	0	0	0	1	1
DQ5 (DQ13)	No	0	1	0	1	1	0	0	1	0	0	0	1	1	1	0	0
DQ6 (DQ14)	Yes	1	0	1	0	0	1	1	0	1	1	1	0	0	0	1	1
DQ7 (DQ15)	No	0	1	0	1	1	0	0	1	0	0	0	1	1	1	0	0

Notes

1. The patterns contained in MR32 and MR40 are transmitted on lower byte select : DQ[7:0] or upper byte select : DQ[15:8], DMI[0] or DMI[1] when RD DQ Calibration is initiated via a MPC-1 [RD DQ Calibration] command. The pattern transmitted serially on each data lane, organized "little endian" such that the low-order bit in a byte is transmitted first. If the data pattern is 27H, then the first bit transmitted will be a '1', followed by '1', '1', '0', '0', '1', '0', and '0'. The bit stream will be 00100111 ..
2. MR15 and MR20 may be used to invert the MR32/MR40 data pattern on the DQ pins. See MR15 for more information. Data is never inverted on the DMI[0] pins.
3. The data pattern is not transmitted on the DMI[0] or DMI[1] pins if DBI-RD is disabled via MR3 OP[6].
4. No Data Bus Inversion (DBI) function is enacted during RD DQ Calibration, even if DBI is enabled in MR3 OP[6].

2.33. DQS-DQ Training

The LPDDR4-SDRAM uses an un-matched DQS-DQ path to enable high speed performance and save power in the DRAM. As a result, the DQS strobe must be trained to arrive at the DQ latch center-aligned with the Data eye. The SDRAM DQ receiver is located at the DQ pad, and has a shorter internal delay in the SDRAM than does the DQS signal. The SDRAM DQ receiver will latch the data present on the DQ bus when DQS reaches the latch, and training is accomplished by delaying the DQ signals relative to DQS such that the Data eye arrives at the receiver latch centered on the DQS transition.

Two modes of training are available in LPDDR4:

- Command-based FIFO WR/RD with user patterns
- A internal DQS clock-tree oscillator, to determine the need for, and the magnitude of, required training.

The command-based FIFO WR/RD uses the MPC command with operands to enable this special mode of operation. When issuing the MPC command, if OP6 is set LOW then the DRAM will perform a NOP command. When OP6 is set HIGH, then OP5:0 enable training functions or are reserved for future use (RFU). MPC commands that initiate a Read FIFO, READ DQ Calibration or Write FIFO to the SDRAM must be followed immediately by a CAS-2 command. See "Multi Purpose Command (MPC) Definition" for more information.

To perform Write Training, the controller can issue a MPC [Write DQ FIFO] command with OP[6:0] set as described in the MPC Definition section, followed immediately by a CAS-2 command (CAS-2 operands should be driven LOW) to initiate a Write DQ FIFO. Timings for MPC [Write DQ FIFO] are identical to a Write command, with WL (Write Latency) timed from the 2nd rising clock edge of the CAS-2 command. Up to 5 consecutive MPC [Write DQ FIFO] commands with user defined patterns may be issued to the SDRAM to store up to 80 values (BL16 x5) per pin that can be read back via the MPC [Read DQ FIFO] command. Write/Read FIFO Pointer operation is described later in this section.

After writing data to the SDRAM with the MPC [Write DQ FIFO] command, the data can be read back with the MPC [Read DQ FIFO] command and results compared with "expect" data to see if further training (DQ delay) is needed. MPC [Read DQ FIFO] is initiated by issuing a MPC command with OP[6:0] set as described in the MPC Definition section, followed immediately by a CAS-2 command (CAS-2 operands must be driven LOW). Timings for the MPC [Read DQ FIFO] command are identical to a Read command, with RL (Read Latency) timed from the 2nd rising clock edge of the CAS-2 command.

Read DQ FIFO is non-destructive to the data captured in the FIFO, so data may be read continuously until it is either overwritten by a Write DQ FIFO command or disturbed by CKE LOW or any of the following commands; Write, Masked Write, Read, Read DQ Calibration and a MRR. If fewer than 5 Write DQ FIFO commands were executed, then unwritten registers will have un-defined (but valid) data when read back.

The following command about MRW is only allowed from MPC [Write DQ FIFO] command to MPC [Read DQ FIFO].

Allowing MRW command is for OP[7]:FSP-OP, OP[6]:FSP-WR and OP[3]:VRCG of MR13 and MR14. And the rest of MRW command is prohibited.

For example: If 5 Write DQ FIFO commands are executed sequentially, then a series of Read DQ FIFO commands will read valid data from FIFO[0], FIFO[1]...FIFO[4], and will then wrap back to FIFO[0] on the next Read DQ FIFO.

On the other hand, if fewer than 5 Write DQ FIFO commands are executed sequentially (example=3), then a series of Read DQ FIFO commands will return valid data for FIFO[0], FIFO[1], and FIFO[2], but the next two Read DQ FIFO commands will return un-defined data for FIFO[3] and FIFO[4] before wrapping back to the valid data in FIFO[0].

2.33.1. FIFO Pointer Reset and Synchronism

The Write DQ FIFO pointer is reset under the following conditions:

- Power-up initialization
- RESET_n asserted
- Power-down entry
- Self Refresh Power-Down entry

The MPC [Write DQ FIFO] command advances the WR-FIFO pointer, and the MPC [Read DQ FIFO] advances the RD-FIFO pointer. Also any normal (non-FIFO) Read Operation (RD, RDA) advances both WR-FIFO pointer and RD-FIFO pointer. Issuing (non-FIFO) Read Operation command is inhibited during Write training period. To keep the pointers aligned, the SoC memory controller must adhere to the following restriction at the end of Write training period:

$$b = a + (n * c)$$

Where:

- 'a' is the number of MPC [Write DQ FIFO] commands
- 'b' is the number of MPC [Read DQ FIFO] commands
- 'c' is the FIFO depth (=5 for LPDDR4)
- 'n' is a positive integer, ≥ 0

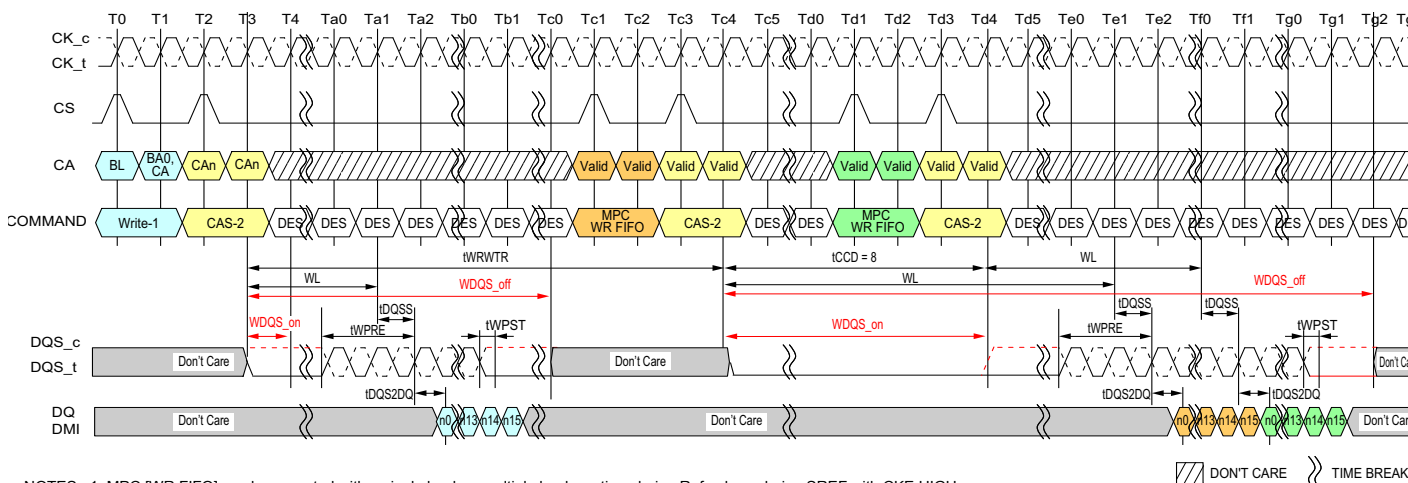

- NOTES:
- MPC [WR FIFO] can be executed with a single bank or multiple banks active, during Refresh, or during SREF with CKE HIGH.
 - Write-1 to MPC is shown as an example of command-to-command timing for MPC. Timing from Write-1 to MPC [WR-FIFO] is tWRWTR.
 - Seamless MPC [WR-FIFO] commands may be executed by repeating the command every tCCD time.
 - MPC [WR-FIFO] uses the same command-to-data timing relationship (WL, tDQSS, tDQS2DQ) as a Write-1 command.
 - A maximum of 5 MPC [WR-FIFO] commands may be executed consecutively without corrupting FIFO data. The 6th MPC [WR-FIFO] command will overwrite the FIFO data from the first command. If fewer than 5 MPC [WR-FIFO] commands are executed, then the remaining FIFO locations will contain undefined data.
 - For the CAS-2 command following a MPC command, the CAS-2 operands must be driven "LOW."
 - To avoid corrupting the FIFO contents, MPC [RD-FIFO] must immediately follow MPC [WR-FIFO]/CAS-2 without any other command disturbing FIFO pointers in-between. FIFO pointers are disturbed by CKE Low, Write, Masked Write, Read, Read DQ Calibration and MRR.
 - BL = 16, Write Postamble = 0.5nCK
 - DES commands are shown for ease of illustration; other commands may be valid at these times.

Figure 119 - Write to MPC [Write FIFO] Operation Timing

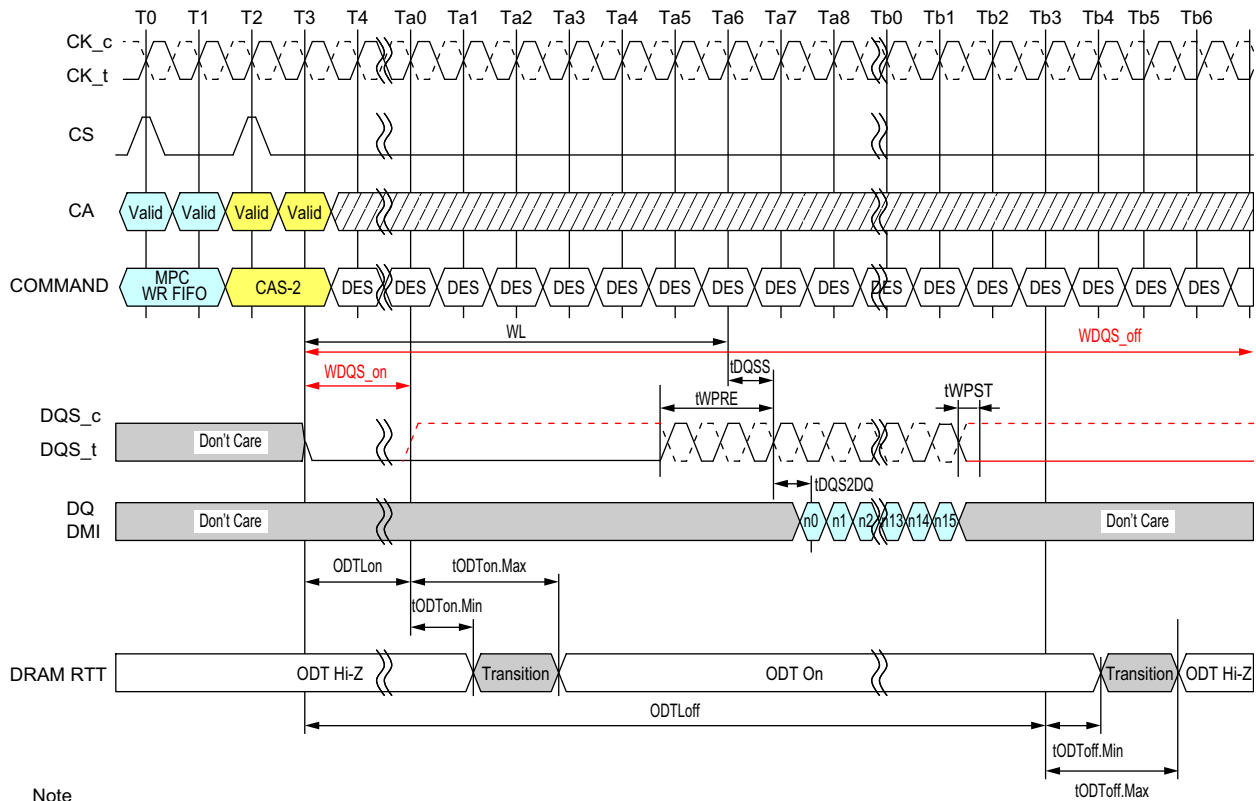

Note

1. MPC [WR FIFO] can be executed with a single bank or multiple banks active, during Refresh, or during SREF with CKE HIGH.
2. MPC [WR-FIFO] uses the same command-to-data/ODT timing relationship (WL , t_{DQSS} , t_{DQS2DQ} , t_{ODTon} , t_{ODTOff} , t_{ODTon} , t_{ODTOff}) as a Write-1 command.
3. For the CAS-2 command immediately following a MPC command, the CAS-2 operands must be driven "LOW."
4. $BL = 16$, Write Postamble = $0.5nCK$
5. DES commands are shown for ease of illustration; other commands may be valid at these times.

DONT CARE
 TIME BREAK

Figure 122 - MPC [Write FIFO] with DQ ODT Timing

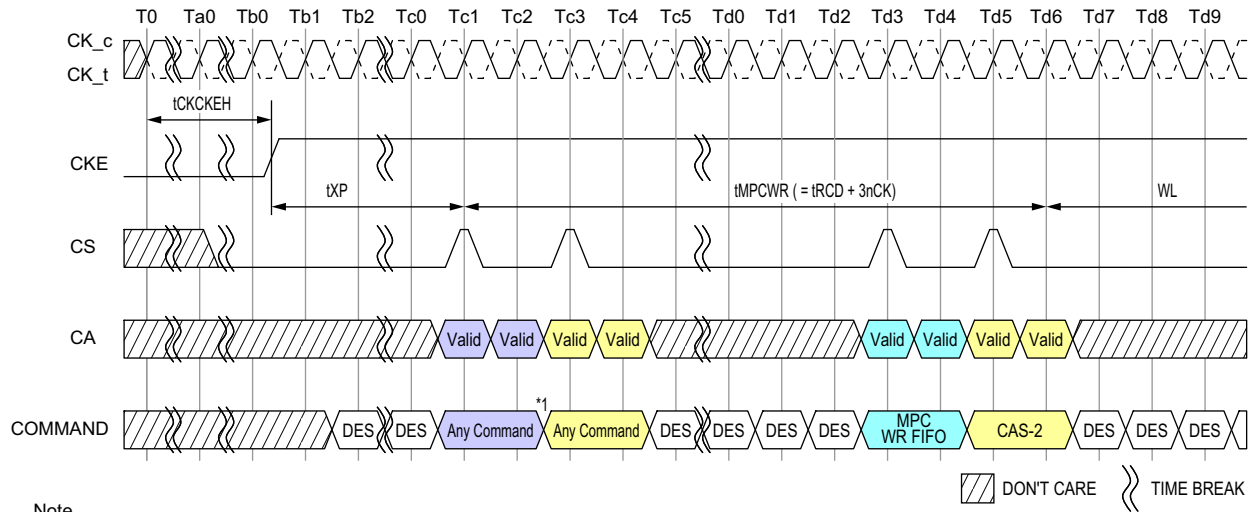

Note
 1. Any commands except MPC WR FIFO and other exception commands defined other section in this document (i.e. MPC Read DQ Cal).
 2. DES commands are shown for ease of illustration; other commands may be valid at these times.

Figure 123 - Power Down Exit to MPC [Write FIFO] Timing

Table 72 - MPC [Write FIFO] AC Timing

Parameter	Symbol	Min Max	Data Rate	Unit	Note
Additional time After tXP has expired until MPC[Write FIFO] CMD may be issued	tMPCWR	Min	tRCD+3nCK	-	

2.34. DQS Interval Oscillator

As voltage and temperature change on the SDRAM die, the DQS clock tree delay will shift and may require re-training. The LPDDR4-SDRAM includes an internal DQS clock-tree oscillator to measure the amount of delay over a given time interval (determined by the controller), allowing the controller to compare the trained delay value to the delay value seen at a later time. The DQS Oscillator will provide the controller with important information regarding the need to re-train, and the magnitude of potential error.

The DQS Interval Oscillator is started by issuing a MPC [Start DQS Osc] command with OP[6:0] set as described in the MPC Operation section, which will start an internal ring oscillator that counts the number of time a signal propagates through a copy of the DQS clock tree.

The DQS Oscillator may be stopped by issuing a MPC [Stop DQS Osc] command with OP[6:0] set as described in the MPC Operation section, or the controller may instruct the SDRAM to count for a specific number of clocks and then stop automatically (See MR23 for more information). If MR23 is set to automatically stop the DQS Oscillator, then the MPC [Stop DQS Osc] command should not be used (illegal). When the DQS Oscillator is stopped by either method, the result of the oscillator counter is automatically stored in MR18 and MR19.

The controller may adjust the accuracy of the result by running the DQS Interval Oscillator for shorter (less accurate) or longer (more accurate) duration. The accuracy of the result for a given temperature and voltage is determined by the following equation:

$$\text{DQS Oscillator Granularity Error} = 2 * (\text{DQS delay}) / \text{run time}$$

Where:

Run Time = total time between start and stop commands

DQS delay = the value of the DQS clock tree delay (tDQS2DQ min/max)

Additional matching error must be included, which is the difference between DQS training circuit and the actual DQS clock tree across voltage and temperature. The matching error is vendor specific.

Therefore, the total accuracy of the DQS Oscillator counter is given by:

$$\text{DQS Oscillator Accuracy} = 1 - \text{Granularity Error} - \text{Matching Error}$$

For example: If the total time between start and stop commands is 100ns, and the maximum DQS clock tree delay is 800ps (tD-QS2DQ max), then the DQS Oscillator Granularity Error is:

$$\text{DQS Oscillator Granularity Error} = 2*(0.8\text{ns}) / 100\text{ns} = 1.6\%$$

This equates to a granularity timing error or 12.8ps.

Assuming a circuit Matching Error of 5.5ps across voltage and temperature, then the accuracy is:

$$\text{DQS Oscillator Accuracy} = 1 - [(12.8+5.5) / 800] = 97.7\%$$

For example: running the DQS oscillator for a longer period improves the accuracy. If the total time between start and stop commands is 500ns, and the maximum DQS clock tree delay is 800ps (tDQS2DQ max), then the DQS Oscillator Granularity Error is:

$$\text{DQS Oscillator Granularity Error} = 2*(0.8\text{ns}) / 500\text{ns} = 0.32\%$$

This equates to a granularity timing error or 2.56ps.

Assuming a circuit Matching Error of 5.5ps across voltage and temperature, then the accuracy is:

$$\text{DQS Oscillator Accuracy} = 1 - [(2.56+5.5) / 800] = 99.0\%$$

The result of the DQS Interval Oscillator is defined as the number of DQS Clock Tree Delays that can be counted within the “run time,” determined by the controller. The result is stored in MR18-OP[7:0] and MR19-OP[7:0]. MR18 contains the least significant bits (LSB) of the result, and MR19 contains the most significant bits (MSB) of the result. MR18 and MR19 are overwritten by the SDRAM when a MPC-1 [Stop DQS Osc] command is received. The SDRAM counter will count to its maximum value ($=2^{16}$) and stop. If the maximum value is read from the mode registers, then the memory controller must assume that the counter overflowed the register and discard the result. The longest “run time” for the oscillator that will not overflow the counter registers can be calculated as follows:

$$\text{Longest Run Time Interval} = 2^{16} * t_{\text{DQS2DQ}}(\text{min}) = 2^{16} * 0.2\text{ns} = 13.1\mu\text{s}$$

2.34.1. Interval Oscillator matching error

The interval oscillator matching error is defined as the difference between the DQS training ckt(interval oscillator) and the actual DQS clock tree across voltage and temperature.

Parameters:

- tDQS2DQ: Actual DQS clock tree delay
- tDQSOSC: Training ckt(interval oscillator) delay
- OSCOffset: Average delay difference over voltage and temp(shown in the figure below)
- OSCMatch: DQS oscillator matching error

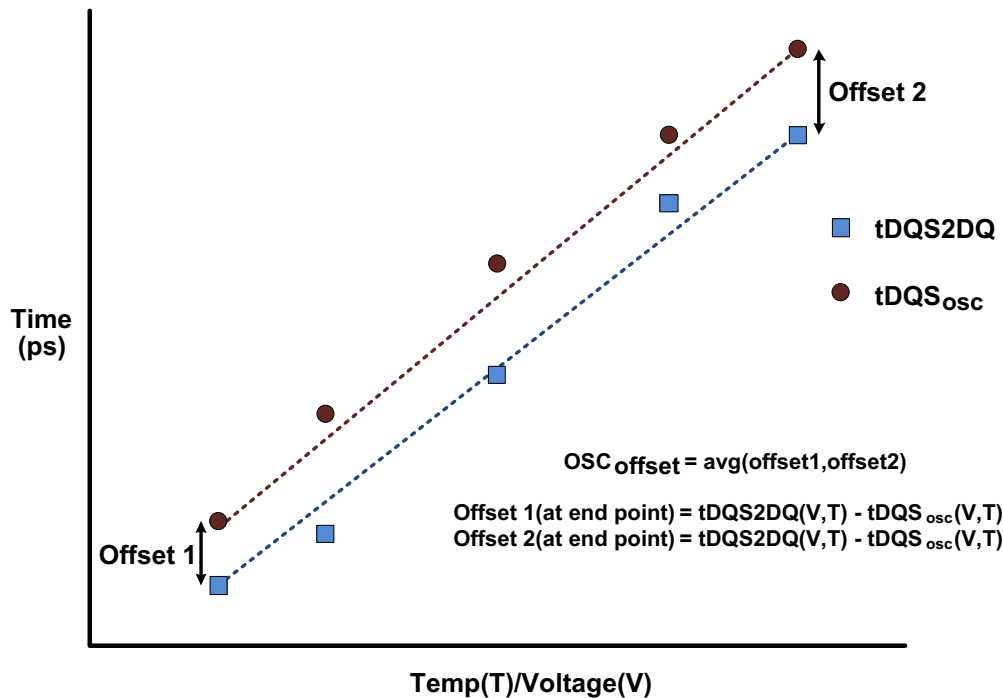

Figure 124 - Interval oscillator offset (OSC_offset)

OSC_{Match} :

$$OSC_{Match} = [tDQS2DQ_{(V,T)} - tDQS_{OSC(V,T)} - OSC_{offset}]$$

tDQS_{OSC} :

$$tDQS_{OSC(V,T)} = Runtime / 2 * Count$$

Table 73 - DQS Oscillator Matching Error Specification

Parameter	Symbol	Min	Max	Units	Notes
DQS Oscillator Matching Error	OSC _{Match}	-20	20	ps	1,2,3,4,5,6,7
DQS Oscillator Offset	OSC _{offset}	-100	100	ps	2,4,7

Note

1. The OSC_{Match} is the matching error per between the actual DQS and DQS interval oscillator over voltage and temp.
2. This parameter will be characterized or guaranteed by design.
3. The OSC_{Match} is defined as the following:

$$OSC_{Match} = [tDQS2DQ_{(V,T)} - tDQS_{OSC(V,T)} - OSC_{offset}]$$

Where $tDQS2DQ_{(V,T)}$ and $tDQS_{OSC(V,T)}$ are determined over the same voltage and temp conditions.

4. The runtime of the oscillator must be at least 200ns for determining $tDQS_{OSC(V,T)}$

$$tDQS_{OSC(V,T)} = Runtime / 2 * Count$$

5. The input stimulus for $tDQS2DQ$ will be consistent over voltage and temp conditions.
6. The OSCoffset is the average difference of the endpoints across voltage and temp.
7. These parameters are defined per channel.
8. $tDQS2DQ(V,T)$ delay will be the average of DQS to DQ delay over the runtime period.

2.34.2. DQS Interval Oscillator Readout Timing

OSC Stop to its counting value readout timing is shown in following figures:

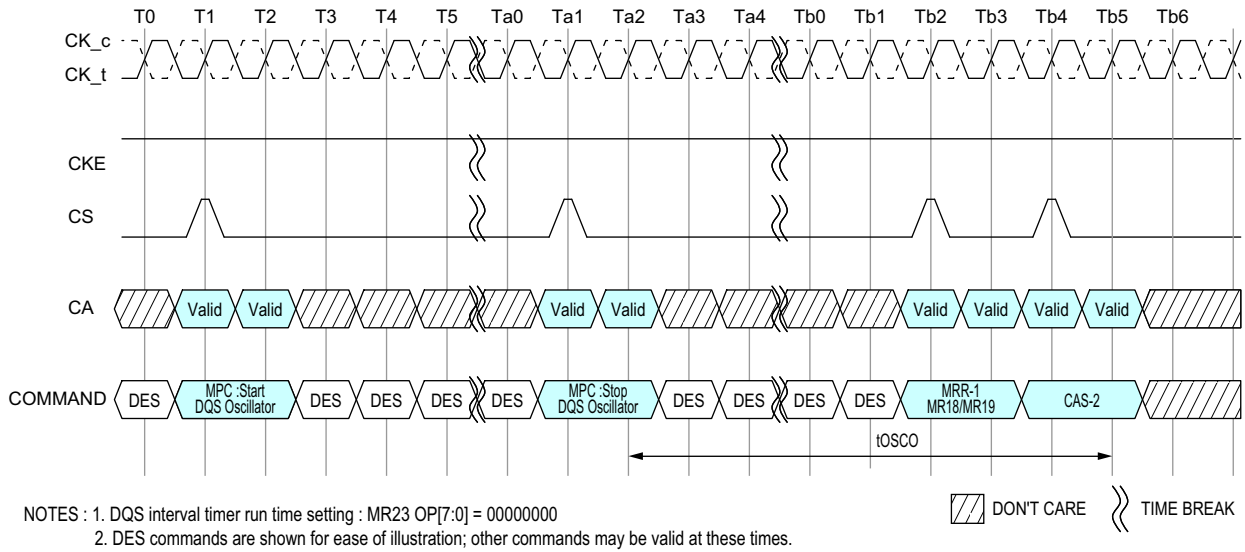

Figure 125 - In case of DQS Interval Oscillator is stopped by MPC Command

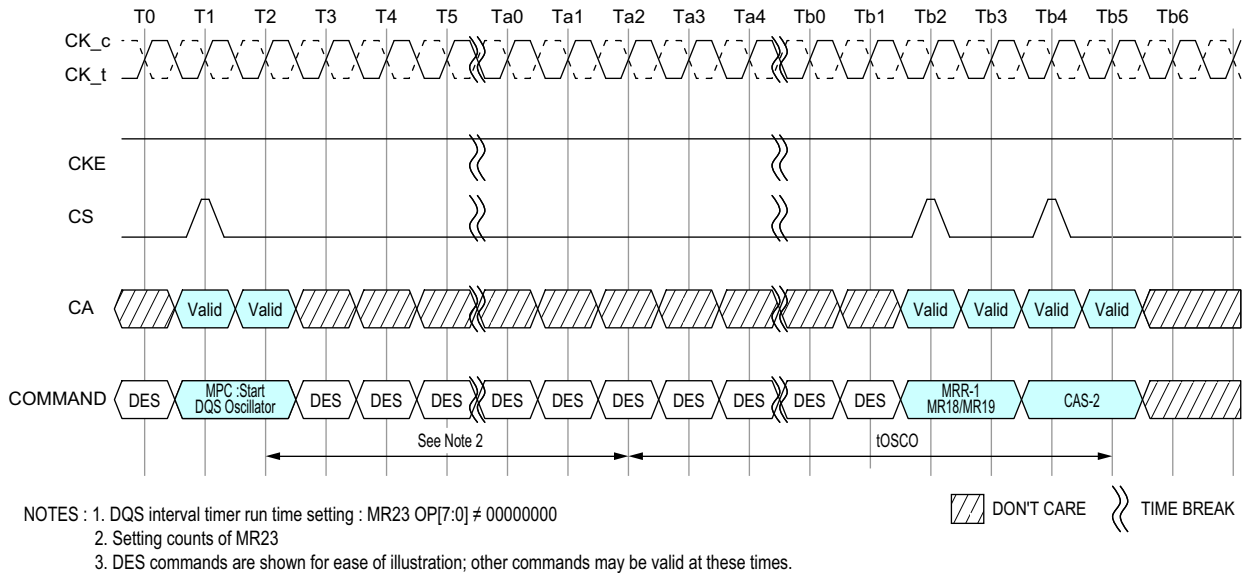

Figure 126 - In case of DQS Interval Oscillator is stopped by DQS interval timer

Table 74 - DQS interval Oscillator AC timing

Parameter	Symbol	Min Max	Data Rate	Unit	Note
Delay time from OSC stop to Mode Register Readout	tOSCO	Min	Max (40ns, 8nCK)	tCK	

Notes

1. Start DQS OSC command is prohibited until tOSCO(Min) is satisfied.

2.35. Read Preamble Training

LPDDR4 READ Preamble Training is supported through the MPC function.

This mode can be used to train or read level the DQS receivers. Once READ Preamble Training is enabled by MR13[OP1] = 1, the LPDDR4 DRAM will drive DQS_t LOW, DQS_c HIGH within tSDO and remain at these levels until an MPC DQ READ Training command is issued.

During READ Preamble Training the DQS preamble provided during normal operation will not be driven by the DRAM. Once the MPC DQ READ Training command is issued, the DRAM will drive DQS_t/DQD_c like a normal READ burst after RL. DRAM may or may not drive DQ[15:0] in this mode.

While in READ Preamble Training Mode, only READ DQ Calibration commands may be issued.

- Issue an MPC [RD DQ Calibration] command followed immediately by a CAS-2 command.
- Each time an MPC [RD DQ Calibration] command followed by a CAS-2 is received by the LPDDR4 SDRAM, a 16-bit data burst will, after the currently set RL, drive the eight bits programmed in MR32 followed by the eight bits programmed in MR40 on all I/O pins.
- The data pattern will be inverted for I/O pins with a '1' programmed in the corresponding invert mask mode register bit.
- Note that the pattern is driven on the DMI pins, but no data bus inversion function is enabled, even if Read DBI is enabled in the DRAM mode register.
- This command can be issued every tCCD seamlessly.
- The operands received with the CAS-2 command must be driven LOW.

READ Preamble Training is exited within tSDO after setting MR13[OP1] = 0.

LPDDR4 supports the READ Preamble Training as optional feature. Refer to vendor specific datasheets.

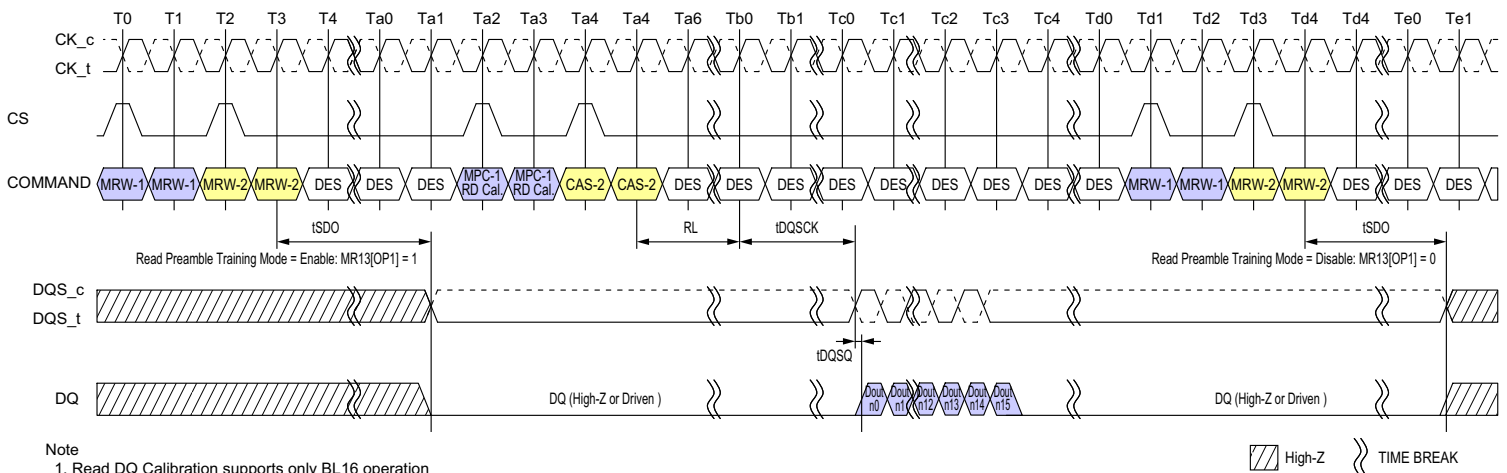

Figure 127 - Read Preamble Training

Table 75 - Read Preamble Training Timings

Parameter	Symbol	min max	533	1066	1600	2133	2667	3200	3733	4266	Unit	Note
Delay from MRW command to DQS Driven	tSDO	max	max(12nCK,20ns)								-	

2.36. Multi Purpose Command (MPC)

LPDDR4-SDRAMs use the MPC command to issue a NOP and to access various training modes. The MPC command is initiated with CS, and CA[5:0] asserted to the proper state at the rising edge of CK, as defined by the Command Truth Table. The MPC command has seven operands (OP[6:0]) that are decoded to execute specific commands in the SDRAM. OP[6] is a special bit that is decoded on the first rising CK edge of the MPC command. When OP[6]=0 then the SDRAM executes a NOP (no operation) command, and when OP[6]=1 then the SDRAM further decodes one of several training commands.

When OP[6]=1 and when the training command includes a Read or Write operation, the MPC command must be followed immediately by a CAS-2 command. For training commands that Read or Write the SDRAM, read latency (RL) and write latency (WL) are counted from the second rising CK edge of the CAS-2 command with the same timing relationship as any normal Read or Write command. The operands of the CAS-2 command following a MPC Read/Write command must be driven LOW. The following MPC commands must be followed by a CAS-2 command:

- Write FIFO
- Read FIFO
- Read DQ Calibration

All other MPC commands do not require a CAS-2 command, including:

- NOP
- Start DQS Interval Oscillator
- Stop DQS Interval Oscillator
- Start ZQ Calibration
- Latch ZQ Calibration

Table 76 - MPC Command Definition

Command	SDR Command Pins (2)		SDR CA Pins (6)						CK_t edge	Notes	
	CKE		CS	CA0	CA1	CA2	CA3	CA4			CA5
	CK_t(n-1)	CK_t(n)									
MPC (Train, NOP)	H	H	H	L	L	L	L	L	OP6	R1	1,2
			L	OP0	OP1	OP2	OP3	OP4	OP5	R2	

Function	Operand	Data	Notes
Training Modes	OP[6:0]	0XXXXXXB: NOP 1000001B: RD FIFO (only supports BL16 operation) 1000011B: RD DQ Calibration (MR32/MR40) 1000101B: RFU 1000111B: WR FIFO (only supports BL16 operation) 1001001B: RFU 1001011B: Start DQS Osc 1001101B: Stop DQS Osc 1001111B: ZQCal Start 1010001B: ZQCal Latch All Others: Reserved	1,2,3

Notes

1. See command truth table for more information
2. MPC commands for Read or Write training operations must be immediately followed by CAS-2 command consecutively without any other commands in between. MPC command must be issued first before issuing the CAS-2 command.
3. Write FIFO and Read FIFO commands will only operate as BL16, ignoring the burst length selected by MR1 OP[1:0].

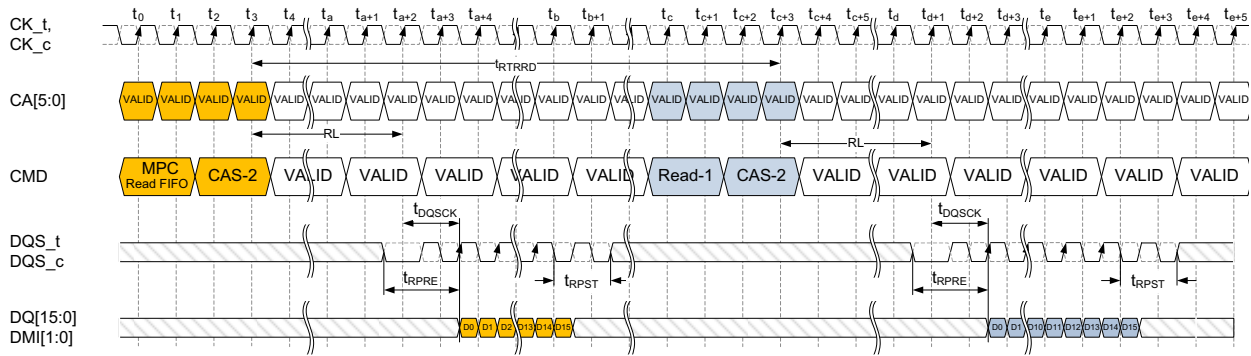

- NOTES :
1. MPC [WR FIFO] can be executed with a single bank or multiple banks active, during Refresh, or during SREF with CKE HIGH.
 2. MPC [RD-FIFO] to Read-1 Operation is shown as an example of command-to-command timing for MPC. Timing from MPC-1 [RD-FIFO] command to Read is t_{RTRRD} .
 3. Seamless MPC [RD-FIFO] commands may be executed by repeating the command every t_{CCD} time.
 4. MPC [RD-FIFO] uses the same command-to-data timing relationship (RL , t_{DQSCK}) as a Read-1 command.
 5. Data may be continuously read from the FIFO without any data corruption. After 5 MPC [RD-FIFO] commands the FIFO pointer will wrap back to the 1st FIFO and continue advancing. If fewer than 5 MPC [WR-FIFO] commands were executed, then the MPC [RD-FIFO] commands to those FIFO locations will return undefined data. See the Write Training section for more information on the FIFO pointer behavior.
 6. For the CAS-2 command immediately following a MPC command, the CAS-2 operands must be driven "LOW."
 7. DMI[1:0] signals will be driven if any of WR-DBI, RD-DBI, or DM is enabled in the mode registers. See Write Training section for more information on DMI behavior.

Figure 130 - MPC [RD FIFO] Operation (Shown with t_{RPRE} =toggling, t_{RPST} =1.5nCK)

Table 77 - Timing Constraints for Training Commands

Previous Command	Next Command	Minimum Delay	Unit	Notes
WR/MWR	MPC [WR FIFO]	tWRWTR	nCK	1
	MPC [RD FIFO]	Not Allowed	-	2
	MPC [RD DQ Calibration]	WL+RU(tDQSS(max)/tCK) +BL/2+RU(tWTR/tCK)	nCK	
RD/MRR	MPC [WR FIFO]	tRTRRD	nCK	3
	MPC [RD FIFO]	Not Allowed	-	2
	MPC [RD DQ Calibration]	tRTRRD	nCK	3
MPC [WR FIFO]	WR/MWR	Not Allowed	-	2
	MPC [WR FIFO]	tCCD	nCK	
	RD/MRR	Not Allowed	-	2
	MPC [RD FIFO]	WL+RU(tDQSS(max)/tCK) +BL/2+RU(tWTR/tCK)	nCK	
	MPC [RD DQ Calibration]	Not Allowed	-	2
MPC [RD FIFO]	WR/MWR	tRTRRD	nCK	3
	MPC [WR FIFO]	tRTW	nCK	4
	RD/MRR	tRTRRD	nCK	3
	MPC [RD FIFO]	tCCD	nCK	
	MPC [RD DQ Calibration]	tRTRRD	nCK	3
MPC [RD DQ Calibration]	WR/MWR	tRTRRD	nCK	3
	MPC [WR FIFO]	tRTRRD	nCK	3
	RD/MRR	tRTRRD	nCK	3
	MPC [RD FIFO]	Not Allowed	-	2
	MPC [RD DQ Calibration]	tCCD	nCK	

Notes

1. tWRWTR = WL + BL/2 + RU(tDQSS(max)/tCK) + max(RU(7.5ns/tCK), 8nCK)
2. No commands are allowed between MPC [WR FIFO] and MPC [RD FIFO] except MRW commands related to training parameters.
3. tRTRRD = RL + RU(tDQSC(max)/tCK) + BL/2 + RD(tRPST) + max(RU(7.5ns/tCK),8nCK)
4. **tRTW (DQ ODT Disabled case; MR11 OP[2:0]=000b)** = RL + RU(tDQSC(max)/tCK) + BL/2 - WL + tWPRE + RD(tRPST)
- tRTW (DQ ODT Enabled case; MR11 OP[2:0]≠000b)** = RL + RU(tDQSC(max)/tCK) + BL/2 + RD(tRPST) - ODTLon - RD(tODTon,min/tCK)

+ 1

2.37. Thermal offset

Because of their tight thermal coupling with the LPDDR4 device, hot spots on an SOC can induce thermal gradients across the LPDDR4 device. As these hot spots may not be located near the device thermal sensor, the devices' temperature compensated self-refresh circuit may not generate enough refresh cycles to guarantee memory retention. To address this shortcoming, the controller can provide a thermal offset that the memory uses to adjust its TCSR circuit to ensure reliable operation.

This offset is provided through MR4(6:5). This temperature offset may modify refresh behavior for the channel to which the offset is provided. It will take a max of 200us to have the change reflected in MR4(2:0) for the channel to which the offset is provided. If the induced thermal gradient from the device temperature sensor location to the hot spot location of the controller is larger than 15 degrees C, then self-refresh mode will not reliably maintain memory contents.

To accurately determine the temperature gradient between the memory thermal sensor and the induced hot spot, the memory thermal sensor location must be provided to the LPDDR4 memory controller.

Support of thermal offset function is optional. Please refer to vendor datasheet to figure out if the function is supported or not.

2.38. Temperature Sensor

LPDDR4 devices feature a temperature sensor whose status can be read from MR4. This sensor can be used to determine an appropriate refresh rate, determine whether AC timing de-rating is required in the elevated temperature range, and/or monitor the operating temperature. Either the temperature sensor or the device TOPER may be used to determine whether operating temperature requirements are being met.

LPDDR4 devices shall monitor device temperature and update MR4 according to tTSI. Upon assertion of CKE (Low to High transition), the device temperature status bits shall be no older than tTSI. MR4 will be updated even when device is in Self Refresh state with CKE HIGH.

When using the temperature sensor, the actual device case temperature may be higher than the TOPER specification that applies for the standard or elevated temperature ranges. For example, TCASE may be above 85°C when MR4[2:0] equals 'b011. LPDDR4 devices shall allow for 2°C temperature margin between the point at which the device updates the MR4 value and the point at which the controller reconfigures the system accordingly. In the case of tight thermal coupling of the memory device to external hot spots, the maximum device temperature might be higher than what is indicated by MR4.

To assure proper operation using the temperature sensor, applications should consider the following factors:

- TempGradient is the maximum temperature gradient experienced by the memory device at the temperature of interest over a range of 2°C.
- ReadInterval is the time period between MR4 reads from the system.
- TempSensorInterval (tTSI) is maximum delay between internal updates of MR4.
- SysRespDelay is the maximum time between a read of MR4 and the response by the system.

In order to determine the required frequency of polling MR4, the system shall use the maximum TempGradient and the maximum response time of the system using the following equation:

$$\text{TempGradient} \times (\text{ReadInterval} + \text{tTSI} + \text{SysRespDelay}) \leq 2^\circ\text{C}$$

Table 78 - Temperature Sensor

Parameter	Symbol	Max/Min	Value	Unit	Notes
System Temperature Gradient	TempGradient	Max	System Dependent	°C/s	
MR4 Read Interval	ReadInterval	Max	System Dependent	ms	
Temperature Sensor Interval	tTSI	Max	32	ms	
System Response Delay	SysRespDelay	Max	System Dependent	ms	
Device Temperature Margin	TempMargin	Max	2	°C	

For example, if TempGradient is 10°C/s and the SysRespDelay is 1 ms:

$$(10^\circ\text{C/s}) \times (\text{ReadInterval} + 32\text{ms} + 1\text{ms}) \leq 2^\circ\text{C}$$

In this case, ReadInterval shall be no greater than 167ms.

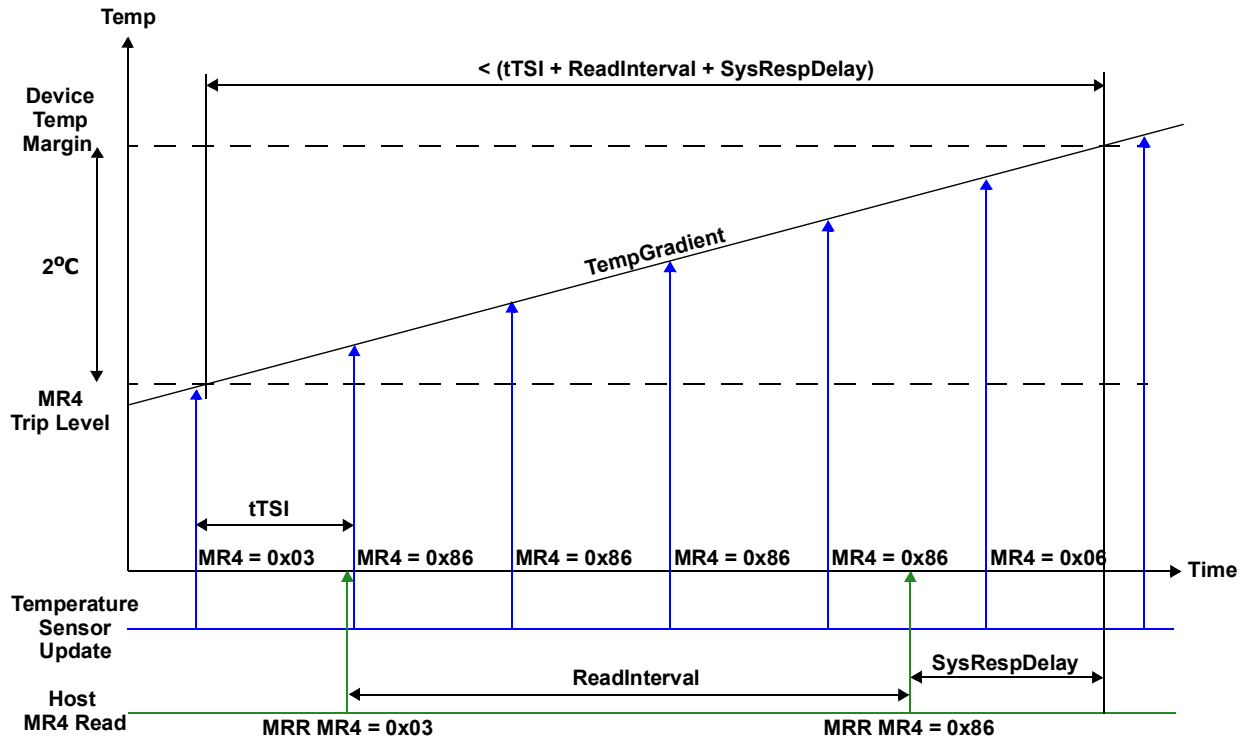

Figure 131 - Temp sensor Timing

2.39. ZQ Calibration

The MPC command is used to initiate ZQ Calibration, which calibrates the output driver impedance across process, temperature, and voltage. ZQ Calibration occurs in the background of device operation.

There are two ZQ Calibration modes initiated with the MPC command: ZQCal Start, and ZQCal Latch. ZQCal Start initiates the SDRAM's calibration procedure, and ZQCal Latch captures the result and loads it into the SDRAM's drivers.

A ZQCal Start command may be issued anytime the LPDDR4-SDRAM is not in a power-down state. A ZQCal Latch Command may be issued anytime outside of power-down after tZQCAL has expired and all DQ bus operations have completed. The CA Bus must maintain a Deselect state during tZQLAT to allow CA ODT calibration settings to be updated. The following mode register fields that modify I/O parameters cannot be changed following a ZQCal Start command and before tZQCAL has expired:

- PU-Cal (Pull-up Calibration VOH Point)
- PDDS (Pull Down Drive Strength and Rx Termination)
- DQ-ODT (DQ ODT Value)
- CA-ODT (CA ODT Value)

2.39.1. ZQCal Reset

The ZQCal Reset command resets the output impedance calibration to a default accuracy of +/- 30% across process, voltage, and temperature. This command is used to ensure output impedance accuracy to +/- 30% when ZQCal Start and ZQCal Latch commands are not used.

The ZQCal Reset command is executed by writing MR10-OP[0]=1B.

Table 79 - ZQCal Timing Parameters

Parameter	Symbol	min max	533	1066	1600	2133	2667	3200	3733	4266	Unit	Note
ZQ Calibration Time	tZQCAL	min	1								us	
ZQ Calibration Latch Time	tZQLAT	min	max(30ns, 8nCK)								ns	
ZQ Calibration Reset Time	tZQRESET	min	max(50ns, 3nCK)								ns	

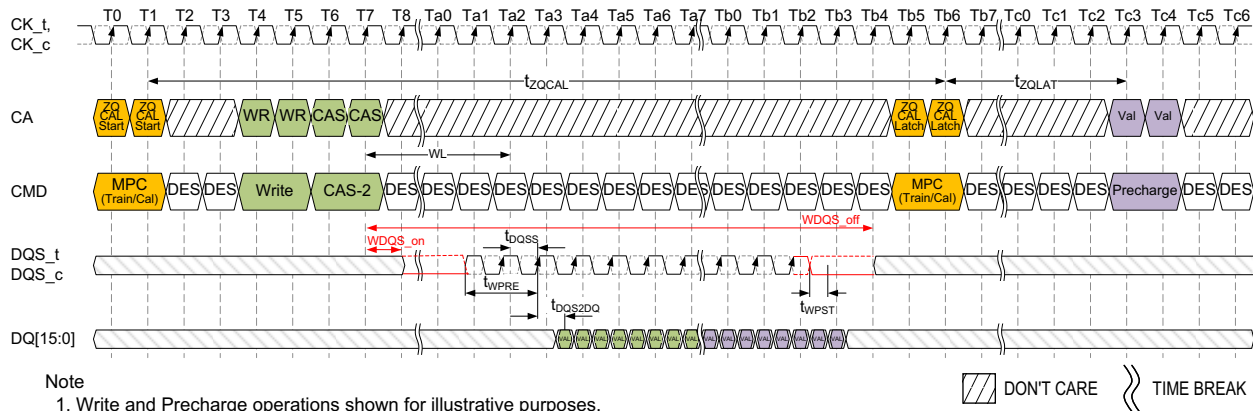

- Note
1. Write and Precharge operations shown for illustrative purposes. Any single or multiple valid commands may be executed within the t_{ZQCAL} time and prior to latching the results.
 2. Before the ZQ-Latch command can be executed, any prior commands utilizing the DQ bus must have completed. Write commands with DQ Termination must be given enough time to turn off the DQ-ODT before issuing the ZQ-Latch command. See the ODT section for ODT timing.

Figure 132 - ZQCal Timing

2.39.3. ZQ External Resistor, Tolerance, and Capacitive Loading

To use the ZQ calibration function, a 240 ohm +/- 1% tolerance external resistor must be connected between the ZQ pin and VDDQ.

If the system configuration shares the CA bus to form a x32 (or wider) channel, the ZQ pin of each die's x16 channel shall use a separate ZQCal resistor.

If the system configuration has more than one rank, and if the ZQ pins of both ranks are attached to a single resistor, then the SDRAM controller must ensure that the ZQ Cal's don't overlap.

The total capacitive loading on the ZQ pin must be limited to 25pF.

2.39.3.1. ZQ Wiring for Byte-mode PKG including mixed configuration

Standard LPDDR4 package ballmaps allocate one ZQ ball per die. Byte-mode packages potentially support more die for higher package memory density. In order to use ballmaps developed for Standard LPDDR4, an alternate ZQ ball wiring strategy is employed when packages contain Byte-mode devices as shown in Figure in section 2.1.

Since the wiring strategy for Byte-mode and Mixed packages shares a single ZQ resistor among ranks, applications must ensure that the ZQ cal's do not overlap. (See section 4.33.2.1)

Multi-rank packages containing Byte-mode devices place additional loading on the I/O and power topologies and therefore may not be appropriate for all application environments.

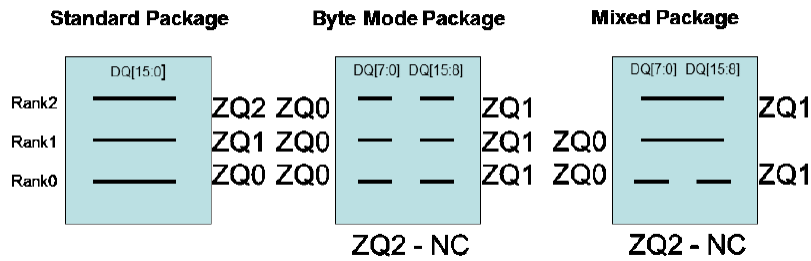

2.40. Pull up/Pull down Driver Characteristics and Calibration

Table 80 - Pull-down Driver Characteristics, with ZQ Calibration

R_{ONPD,nom}	Resistor	Min	Nom	Max	Unit
40 Ohm	R _{ON40PD}	0.9	1.0	1.1	RZQ/6
48 Ohm	R _{ON48PD}	0.9	1.0	1.1	RZQ/5
60 Ohm	R _{ON60PD}	0.9	1.0	1.1	RZQ/4
80 Ohm	R _{ON80PD}	0.9	1.0	1.1	RZQ/3
120 Ohm	R _{ON120PD}	0.9	1.0	1.1	RZQ/2
240 Ohm	R _{ON240PD}	0.9	1.0	1.1	RZQ/1

Notes

1. All values are after ZQ calibration. Without ZQ Calibration RONPD values are +/- 30%

Table 81 - Pull-up Driver Characteristics, with ZQ Calibration

VOH_{pu,nom}	VOH,nom(mV)	Min	Nom	Max	Unit
VDDQ*0.5	300	0.9	1.0	1.1	VOH,nom
VDDQ*0.6	360	0.9	1.0	1.1	VOH,nom

Notes

1. All values are after ZQ Calibration. Without ZQ Calibration VOH(nom) values are ± 30%.
2. VOH,nom (mV) values are based on a nominal VDDQ = 0.6 V.

Table 82 - Terminated Valid Calibration Points

VOH_{pu,nom}	ODT Values					
	240	120	80	60	48	40
VDDQ*0.5	Valid	Valid	Valid	DNU	DNU	DNU
VDDQ*0.6	DNU	Valid	DNU	Valid	Valid	Valid

Notes

1. Once the output is calibrated for a given VOH(nom) calibration point, the ODT value may be changed without recalibration.
2. If the VOH(nom) calibration point is changed, then re-calibration is required.
3. DNU = Do Not Use

2.41. On Die Termination Command/Address Bus

ODT (On-Die Termination) is a feature of the LPDDR4 SDRAM that allows the SDRAM to turn on/off termination resistance for CK_t, CK_c, CS and CA[5:0] signals without the ODT control pin.

The ODT feature is designed to improve signal integrity of the memory channel by allowing the DRAM controller to turn on and off termination resistance for any target DRAM devices via Mode Register setting.

A simple functional representation of the DRAM ODT feature is shown in the Figure below

Figure 133 - Functional Representation of CA ODT

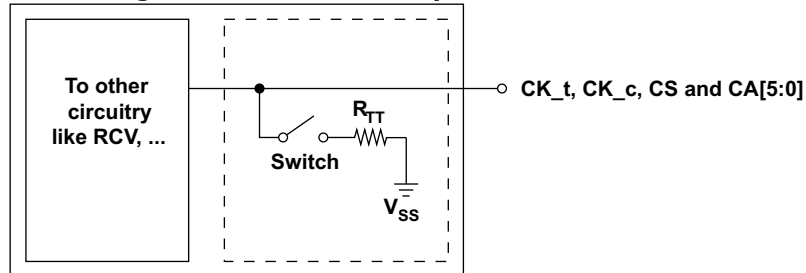

2.41.1. ODT Mode Register and ODT State Table

ODT termination values are set and enabled via MR11. The CA bus (CK_t, CK_C, CS, CA[5:0]) ODT resistance values are set by MR11 OP[6:4]. The default state for the CA is ODT disabled.

ODT is applied on the CA bus to the CK_t, CK_c, CS and CA[5:0] signals. Generally, only one termination load will be present even if multiple devices are sharing the command signals. In contrast to LPDDR4 where the ODT_CA input is used in combination with mode registers, LPDDR4X uses mode registers exclusively to enable CA termination. Before enabling CA termination via MR11, all ranks should have appropriate MR22 termination settings programmed. In a multi rank system, the terminating rank should be trained first, followed by the nonterminating rank(s).

Table 83 - Command Bus ODT State

ODTE-CA MR11[6:4]	ODT_CA bond pad	ODTD-CA MR22[5]	ODTE-CK MR22[3]	ODTE-CS MR22[4]	ODT State for CA	ODT State for CK_t/CK_c	ODT State for CS
Disabled ¹	Valid ²	Valid ²	Valid ²	Off	Off	Off	Disabled ¹
Valid ²	0	0	0	On	On	On	Valid ²
Valid ²	0	0	1	On	On	Off	Valid ²
Valid ²	0	1	0	On	Off	On	Valid ²
Valid ²	0	1	1	On	Off	Off	Valid ²
Valid ²	1	0	0	Off	On	On	Valid ²
Valid ²	1	0	1	Off	On	Off	Valid ²

Notes

1. Default value
2. "Valid" means "0 or 1"

2.41.2. ODT Mode Register and ODT characteristics

A functional representation of the on-die termination is shown in the figure below.

$$RTT = V_{out} / |I_{out}|$$

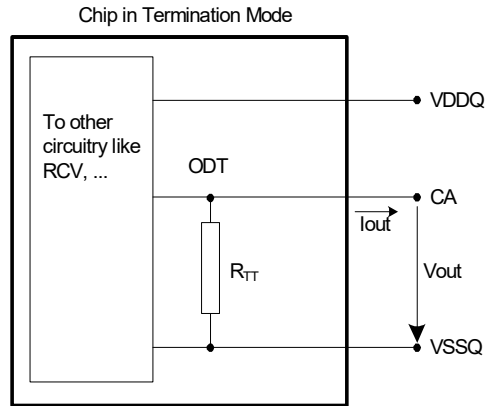

Figure 134 - CA On Die Termination

Table 84 - ODT DC Electrical Characteristics

(assuming RZQ=240Ω +/- 1% over the entire operating temperature range after a proper ZQ calibration up to 3200Mbps)

MR11 OP[6:4]	RTT	Vout	Min	Nom	Max	Unit	Notes
001	240Ω	VOLdc=0.1*VDD2	0.8	1.0	1.1	RZQ	1,2,3
		VOMdc=0.33*VDD2	0.9	1.0	1.1		1,2,3
		VOHdc=0.5*VDD2	0.9	1.0	1.2		1,2,3
010	120Ω	VOLdc=0.1*VDD2	0.8	1.0	1.1	RZQ/2	1,2,3
		VOMdc=0.33*VDD2	0.9	1.0	1.1		1,2,3
		VOHdc=0.5*VDD2	0.9	1.0	1.2		1,2,3
011	80Ω	VOLdc=0.1*VDD2	0.8	1.0	1.1	RZQ/3	1,2,3
		VOMdc=0.33*VDD2	0.9	1.0	1.1		1,2,3
		VOHdc=0.5*VDD2	0.9	1.0	1.2		1,2,3
100	60Ω	VOLdc=0.1*VDD2	0.8	1.0	1.1	RZQ/4	1,2,3
		VOMdc=0.33*VDD2	0.9	1.0	1.1		1,2,3
		VOHdc=0.5*VDD2	0.9	1.0	1.2		1,2,3
101	48Ω	VOLdc=0.1*VDD2	0.8	1.0	1.1	RZQ/5	1,2,3
		VOMdc=0.33*VDD2	0.9	1.0	1.1		1,2,3
		VOHdc=0.5*VDD2	0.9	1.0	1.2		1,2,3
110	40Ω	VOLdc=0.1*VDD2	0.8	1.0	1.1	RZQ/6	1,2,3
		VOMdc=0.33*VDD2	0.9	1.0	1.1		1,2,3
		VOHdc=0.5*VDD2	0.9	1.0	1.2		1,2,3
Mismatch CA-CA within clk group		0.33*VDD2	-		TBD ¹	%	1,2,4

Notes

1. The tolerance limits are specified after calibration with stable voltage and temperature. For the behavior of the tolerance limits if temperature or voltage changes after calibration, see following section on voltage and temperature sensitivity.
2. Pull-dn ODT resistors are recommended to be calibrated at 0.33*VDD2. Other calibration schemes may be used to achieve the linearity spec shown above, e.g. calibration at 0.5*VDD2 and 0.1*VDD2.
3. Measurement definition for RTT: tbd
4. CA to CA mismatch within clock group (CA,CS) variation for a given component including CK_t and CK_c (characterized).

$$CA - CA_{mismatch} = \frac{RODT(max) - RODT(min)}{RODT(avg)}$$

2.41.3. ODT for Command/Address update time

ODT for Command/Address update time after Mode Register set are shown in the figure below

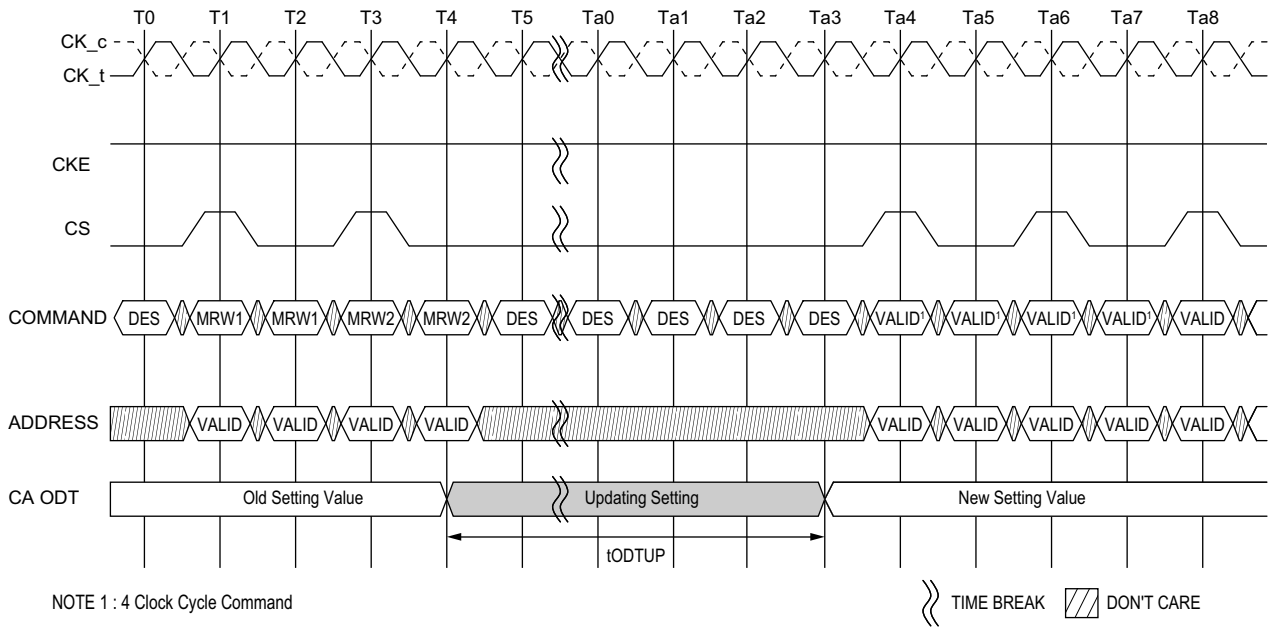

Figure 135 - CA ODT setting update timing in 4 Clock Cycle Command

Table 85 - ODT CA AC timing

Parameter	Symbol	min max	LPDDR4-1600/1866/2133/2400/3200/3733/4266	Units	Note
ODT CA Value Update Time	tODTUP	Min	RU (tbd ns/tCK(avg))		

2.42. On-die Termination

ODT (On-Die Termination) is a feature of the LPDDR4 SDRAM that allows the DRAM to turn on/off termination resistance for each DQ, DQS_t, DQS_c and DMI signals without the ODT control pin. The ODT feature is designed to improve signal integrity of the memory channel by allowing the DRAM controller to turn on and off termination resistance for any target DRAM devices during Write operation.

The ODT feature is off and cannot be supported in Power Down and Self-Refresh modes. A simple functional representation of the DRAM ODT feature is shown in following Figure.

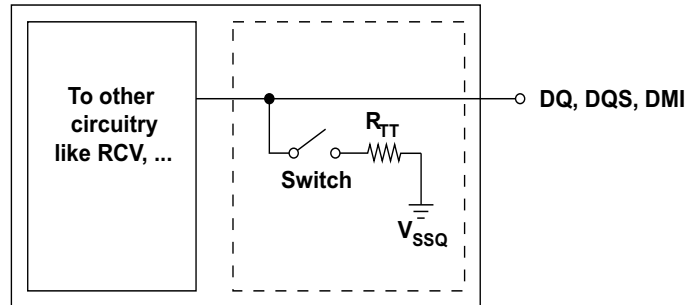

Figure 136 - Functional Representation of DQ ODT

The switch is enabled by the internal ODT control logic, which uses the Write-1 or Mask Write-1 command and other mode register control information. The value of R_{TT} is determined by the settings of Mode Register bits.

2.42.1. ODT Mode Register

The ODT Mode is enabled if MR11 OP[3:0] are non zero. In this case, the value of R_{TT} is determined by the settings of those bits. The ODT Mode is disabled if MR11 OP[3] = 0.

2.42.2. Asynchronous ODT

When ODT Mode is enabled in MR11 OP[3:0], DRAM ODT is always Hi-Z. DRAM ODT feature is automatically turned ON asynchronously based on the Write-1 or Mask Write-1 command that DRAM samples. After the write burst is complete, DRAM ODT featured is automatically turned OFF asynchronously.

Following timing parameters apply when DRAM ODT mode is enabled:

- ODTLon, tODTon,min, tODTon,max
- ODTLoff, tODToff,min, tODToff,max

ODTLon is a synchronous parameter and it is the latency from CAS-2 command to tODTon reference.

ODTLon latency is a fixed latency value for each speed bin. Each speed bin has a different ODTLon latency.

Minimum R_{TT} turn-on time (tODTon,min) is the point in time when the device termination circuit leaves high impedance state and ODT resistance begins to turn on.

Maximum R_{TT} turn on time (tODTon,max) is the point in time when the ODT resistance is fully on.

tODTon,min and tODTon,max are measured once ODTLon latency is satisfied from CAS-2 command.

ODTLoff is a synchronous parameter and it is the latency from CAS-2 command to tODToff reference.

ODTLoff latency is a fixed latency value for each speed bin. Each speed bin has a different ODTLoff latency. Minimum RTT turn-off time (tODToff,min) is the point in time when the device termination circuit starts to turn off the ODT resistance.

Maximum ODT turn off time (tODToff,max) is the point in time when the on-die termination has reached high impedance. tODToff,min and tODToff,max are measured once ODTLoff latency is satisfied from CAS-2 command.

Table 86 - ODTLon and ODTLoff Latency Values

ODTLon Latency ^{a)}		ODTLoff Latency ^{b)}		Lower Frequency Limit (>)	Upper Frequency Limit (≤)
WL Set "A"	WL Set "B"	WL Set "A"	WL Set "B"		
N/A	N/A	N/A	N/A	10	266
N/A	N/A	N/A	N/A	266	533
N/A	6	N/A	22	533	800
4	12	20	28	800	1066
4	14	22	32	1066	1333
6	18	24	36	1333	1600
6	20	26	40	1600	1866
8	24	28	44	1866	2133
nCK	nCK	nCK	nCK	MHz	MHz

a. ODTLon is referenced from CAS-2 command. See timing diagram examples below.

b. ODTLoff is shown in table assumes BL=16. For BL32, 8 tCK should be added.

Table 87 - Asynchronous ODT turn on and turn off timing

Parameter	800~2133MHz	Unit
tODTon,min	1.5	ns
tODTon,max	3.5	ns
tODToff,min	1.5	ns
tODToff,max	3.5	ns

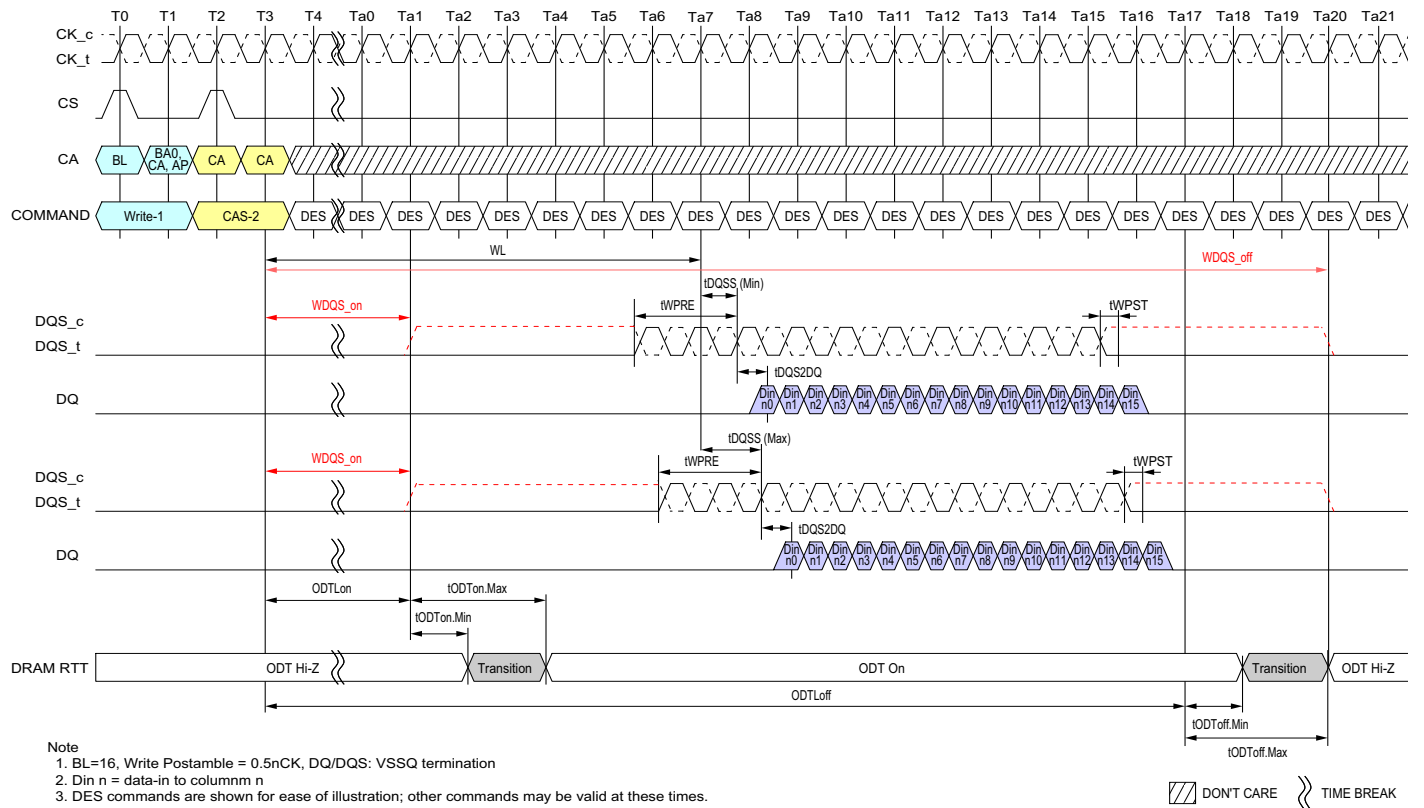
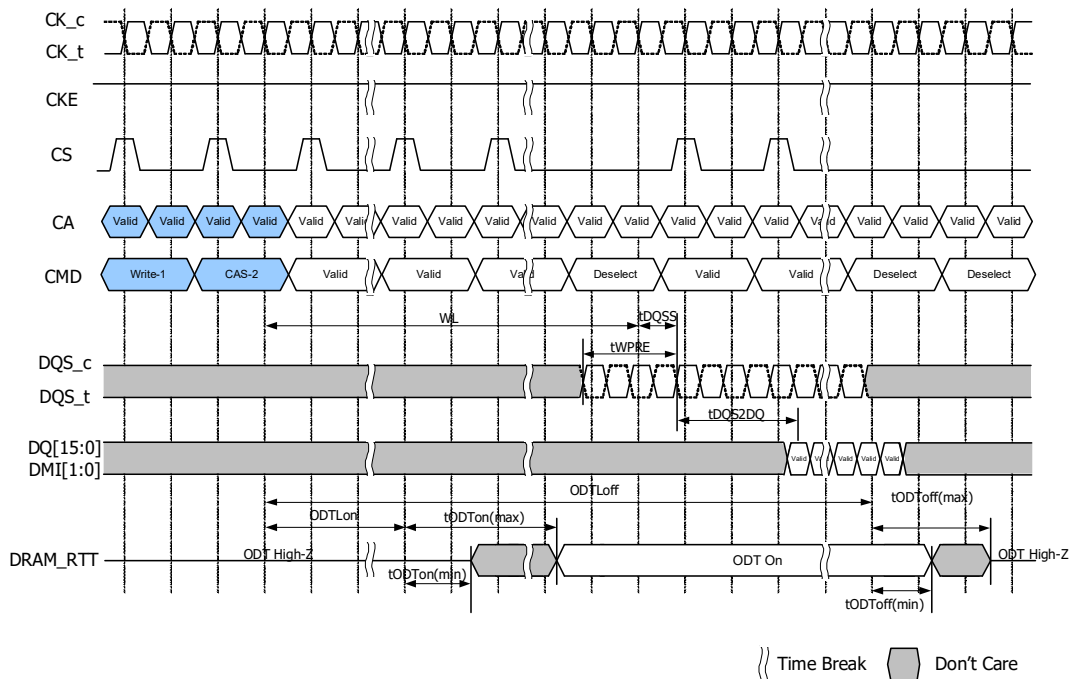
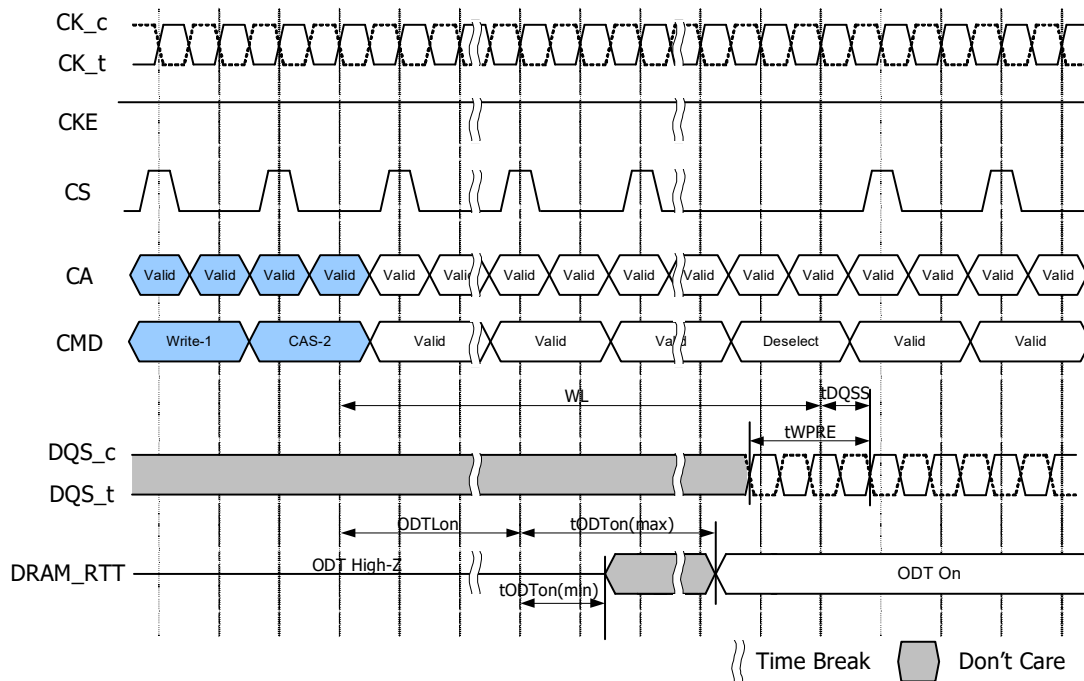

Figure 137 - Asynchronous ODTon/ODTOff Timing



2.42.3. ODT during Write Leveling

If ODT is enabled in MR11 OP[3:0], in Write Leveling mode, DRAM always provides the termination on DQS_t/DQS_c signals. DQ termination is always off in Write Leveling mode regardless.

Table 88 - DRAM Termination Function in Write Leveling Mode

ODT Enabled in MR11	DQS_t/DQS_c termination	DQ termination
Disabled	OFF	OFF
Enabled	ON	OFF

2.43. On Die Termination for DQ, DQS and DMI

On-Die Termination effective resistance R_{TT} is defined by MR bits MR11 OP[2:0].

ODT is applied to the DQ, DMI, DQS_t and DQS_c pins.

A functional representation of the on-die termination is shown in the figure below.

$$R_{TT} = V_{out} / |I_{out}|$$

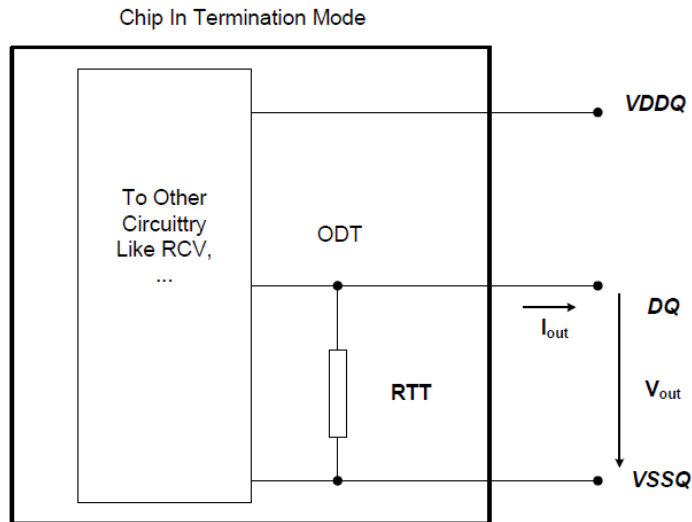

Figure 140 - DQ On Die Termination

Table 89 - ODT DC Electrical Characteristics

(assuming RZQ=240Ω +/- 1% over the entire operating temperature range after a proper ZQ calibration)

MR11 OP[2:0]	RTT	Vout	Min	Nom	Max	Unit	Notes
001	240Ω	VOLdc=0.20*VDDQ	0.8	1.0	1.1	RZQ	1,2
		VOMdc=0.50*VDDQ	0.9	1.0	1.1		1,2
		VOHdc=0.75*VDDQ	0.9	1.0	1.3		1,2
010	120Ω	VOLdc=0.20*VDDQ	0.8	1.0	1.1	RZQ/2	1,2
		VOMdc=0.50*VDDQ	0.9	1.0	1.1		1,2
		VOHdc=0.75*VDDQ	0.9	1.0	1.3		1,2
011	80Ω	VOLdc=0.20*VDDQ	0.8	1.0	1.1	RZQ/3	1,2
		VOMdc=0.50*VDDQ	0.9	1.0	1.1		1,2
		VOHdc=0.75*VDDQ	0.9	1.0	1.3		1,2
100	60Ω	VOLdc=0.20*VDDQ	0.8	1.0	1.1	RZQ/4	1,2
		VOMdc=0.50*VDDQ	0.9	1.0	1.1		1,2
		VOHdc=0.75*VDDQ	0.9	1.0	1.3		1,2
101	48Ω	VOLdc=0.20*VDDQ	0.8	1.0	1.1	RZQ/5	1,2
		VOMdc=0.50*VDDQ	0.9	1.0	1.1		1,2
		VOHdc=0.75*VDDQ	0.9	1.0	1.3		1,2
110	40Ω	VOLdc=0.20*VDDQ	0.8	1.0	1.1	RZQ/6	1,2
		VOMdc=0.50*VDDQ	0.9	1.0	1.1		1,2
		VOHdc=0.75*VDDQ	0.9	1.0	1.3		1,2
Mismatch DQ-DQ within byte		0.50*VDDQ	-		2	%	1,2,3

Notes

1. The tolerance limits are specified after calibration with stable voltage and temperature. For the behavior of the tolerance limits if temperature or voltage changes after calibration, see 3.4 on voltage and temperature sensitivity.
2. Pull-dn ODT resistors are recommended to be calibrated at 0.75*VDDQ and 0.2*VDDQ. Other calibration schemes may be used to achieve the linearity spec shown above, e.g., calibration at 0.75*VDDQ and 0.1*VDDQ.
3. DQ to DQ mismatch within byte variation for a given component including DQS_t and DQS_c (characterized).

$$DQ - DQ_{mismatch} = \frac{RODT(max) - RODT(min)}{RODT(avg)}$$

2.44. Output Driver and Termination Register Temperature and Voltage Sensitivity

If temperature and/or voltage change after calibration, the tolerance limits widen according to the Tables shown below.

Table 90 - Output Driver and Termination Register Sensitivity Definition

Resistor	Definition Point	Min	Max	Unit	Notes
R_{ONPD}	$0.50 \times VDDQ$	$90 - (dR_{on}dT \times \Delta T) - (dR_{on}dV \times \Delta V)$	$110 + (dR_{on}dT \times \Delta T) + (dR_{on}dV \times \Delta V)$	%	1,2
VOH_{PU}	$0.50 \times VDDQ$	$90 - (dVOHdT \times \Delta T) - (dVOHdV \times \Delta V)$	$110 + (dVOHdT \times \Delta T) + (dVOHdV \times \Delta V)$	%	1,2,5
$R_{TT(I/O)}$	$0.50 \times VDDQ$	$90 - (dR_{on}dT \times \Delta T) - (dR_{on}dV \times \Delta V)$	$110 + (dR_{on}dT \times \Delta T) + (dR_{on}dV \times \Delta V)$	%	1,2,3
$R_{TT(In)}$	$0.50 \times VDDQ$	$90 - (dR_{on}dT \times \Delta T) - (dR_{on}dV \times \Delta V)$	$110 + (dR_{on}dT \times \Delta T) + (dR_{on}dV \times \Delta V)$	%	1,2,4

Notes

- $\Delta T = T - T(@ \text{ Calibration})$, $\Delta V = V - V(@ \text{ Calibration})$
- $dRONdT$, $dRONdV$, $dVOHdT$, $dVOHdV$, $dRTTdV$, and $dRTTdT$ are not subject to production test but are verified by design and characterization.
- This parameter applies to Input/Output pin such as DQS, DQ and DMI and the input pins such as CK, CA, and CS.
- Refer to Section "Pull Up/Pull Down Driver Characteristics for VOHPU".

Table 91 - Output Driver and Termination Register Temperature and Voltage Sensitivity

Symbol	Parameter	Min	Max	Unit
dR_{ONdT}	R_{ON} Temperature Sensitivity	0.00	0.75	%/°C
dR_{ONdV}	R_{ON} Voltage Sensitivity	0.00	0.20	%/mV
$dVOHdT$	VOH Temperature Sensitivity	0.00	0.75	%/°C
$dVOHdV$	VOH Voltage Sensitivity	0.00	0.35	%/mV
dR_{TTdT}	R_{TT} Temperature Sensitivity	0.00	0.75	%/°C
dR_{TTdV}	R_{TT} Voltage Sensitivity	0.00	0.20	%/mV

2.45. Power Down Mode

2.45.1. Power Down Entry and Exit

Power-down is asynchronously entered when CKE is driven LOW. CKE must not go LOW while the following operations are in progress:

- Mode Register Read
- Mode Register Write
- Read
- Write
- VREF(CA) Range and Value setting via MRW
- VREF(DQ) Range and Value setting via MRW
- Command Bus Training mode Entering/Exiting via MRW
- VRCG High Current mode Entering/Exiting via MRW

And the LPDDR4 DRAM cannot be placed in power-down state during “Start DQS Interval Oscillator” operation.

CKE can go LOW while any other operations such as row activation, Precharge, Auto-Precharge, or Refresh are in progress. The power-down IDD specification will not be applied until such operations are complete. Power-down entry and exit are shown in Figure 137.

Entering power-down deactivates the input and output buffers, excluding CKE and Reset_n. To ensure that there is enough time to account for internal delay on the CKE signal path, CS input is required stable Low level and CA input level is don't care after CKE is driven LOW, this timing period is defined as tCKELCS. Clock input is required after CKE is driven LOW, this timing period is defined as tCKELCK. CKE LOW will result in deactivation of all input receivers except Reset_n after tCKELCK has expired. In power-down mode, CKE must be held LOW; all other input signals except Reset_n are "Don't Care". CKE LOW must be maintained until tCKE,min is satisfied.

No refresh operations are performed in power-down mode except Self Refresh power-down. The maximum duration in non-Self Refresh power-down mode is only limited by the refresh requirements outlined in the Refresh command section.

The power-down state is asynchronously exited when CKE is driven HIGH. CKE HIGH must be maintained until tCKE,min is satisfied. A valid, executable command can be applied with power-down exit latency tXP after CKE goes HIGH. Power-down exit latency is defined in the AC timing parameter table.

Clock frequency change or Clock Stop is inhibited during tCMDCKE, tCKELCK, tCKCKEH, tXP, tMRWCKEL and tZQCKE periods.

If power-down occurs when all banks are idle, this mode is referred to as idle power-down. If power-down occurs when there is a row active in any bank, this mode is referred to as active power-down. And If power-down occurs when Self Refresh is in progress, this mode is referred to as Self Refresh power-down in which the internal refresh is continuing in the same way as Self Refresh mode.

VDDQ may be turned off during power-down after tCKELCK(Max(5ns,5nCK)) is satisfied(Refer to Figure 137 about tCKELCK). Prior to exiting power-down, V_{DDQ} must be within its minimum/maximum operating range.

When CA, CK and/or CS ODT is enabled via MR11 OP[6:4] and also via MR22 or CA-ODT pad setting, the rank providing ODT will continue to terminate the command bus in all DRAM states including power-down when VDDQ is stable and within its minimum/maximum operating range.

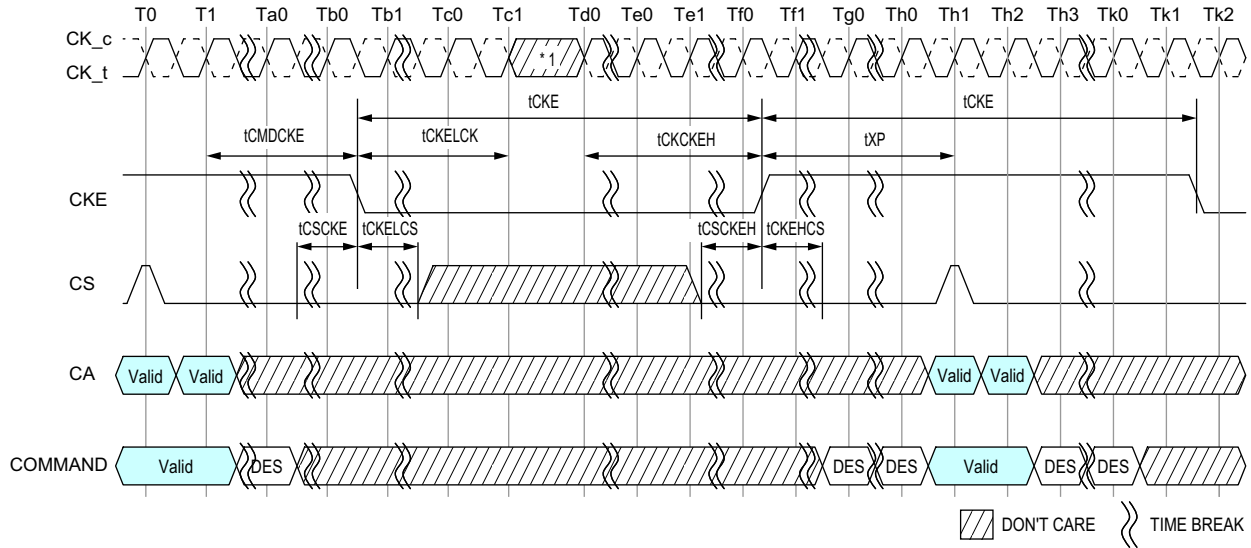

NOTES : 1. Input clock frequency can be changed or the input clock can be stopped or floated during power-down, provided that upon exiting power-down, the clock is stable and within specified limits for a minimum of tCKCKEH of stable clock prior to power-down exit and the clock frequency is between the minimum and maximum specified frequency for the speed grade in use.

Figure 141 - Basic Power-down Entry and Exit Timing

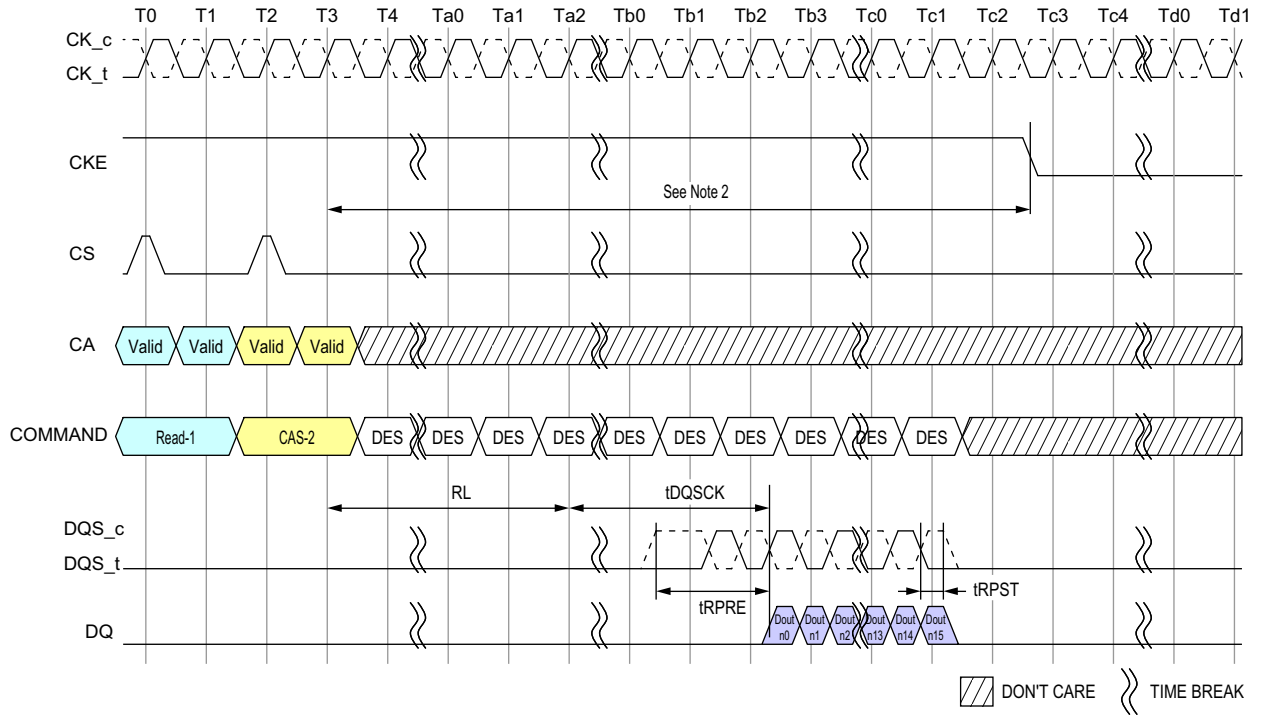

NOTES : 1. CKE must be held HIGH until the end of the burst operation.

2. Minimum Delay time from Read Command or Read with Auto-Precharge Command to falling edge of CKE signal is as follows.

Read Post-amble = 0.5nCK : MR1 OP[7]=[0] : $(RL \times tCK) + tDQSCK(Max) + ((BL/2) \times tCK) + 1tCK$

Read Post-amble = 1.5nCK : MR1 OP[7]=[1] : $(RL \times tCK) + tDQSCK(Max) + ((BL/2) \times tCK) + 2tCK$

Figure 142 - Read and Read with Auto-precharge to Power-Down Entry

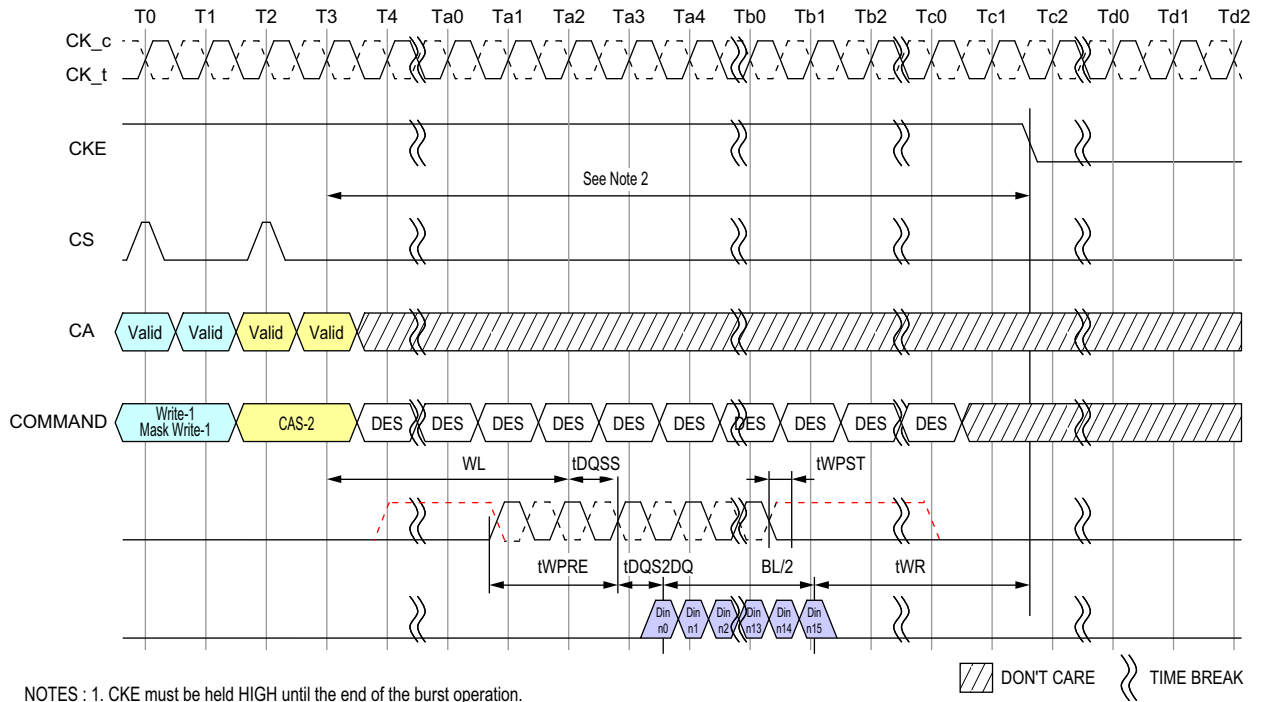

- NOTES :
1. CKE must be held HIGH until the end of the burst operation.
 2. Minimum Delay time from Write Command or Mask Write Command to falling edge of CKE signal is as follows.
 $(WL \times tCK) + tDQSS(Max) + tDQS2DQ(Max) + ((BL/2) \times tCK) + tWR$
 3. This timing is applied regardless of DQ ODT Disable/Enable setting: MR11[OP2:0].
 4. This timing diagram only applies to the Write and Mask Write Commands without Auto-Precharge.

Figure 143 - Write and Mask Write to Power-Down Entry

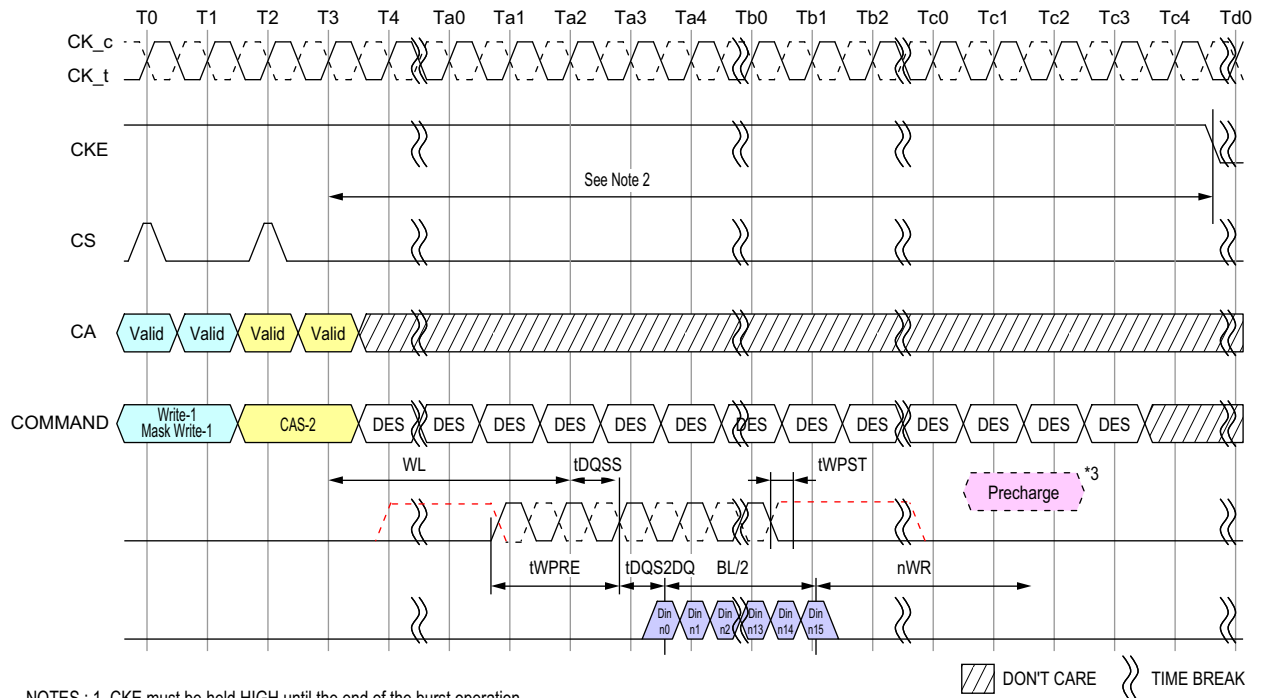

- NOTES : 1. CKE must be held HIGH until the end of the burst operation.
 2. Delay time from Write with Auto-Precharge Command or Mask Write with Auto-Precharge Command to falling edge of CKE signal is more than $(WL \times tCK) + tDQSS(Max) + tDQS2DQ(Max) + ((BL/2) \times tCK) + (nWR \times tCK) + (2 \times tCK)$
 3. Internal Precharge Command
 4. This timing is applied regardless of DQ ODT Disable/Enable setting: MR11[OP2:0].

Figure 144 - Write and Masked Write with Auto Precharge to Power-Down Entry

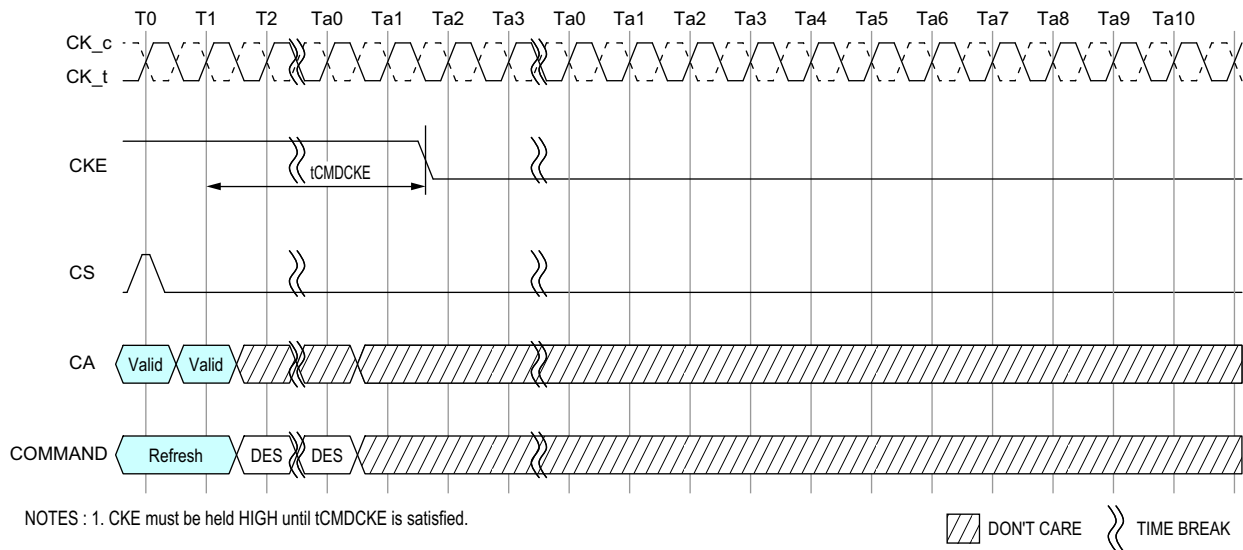

- NOTES : 1. CKE must be held HIGH until tCMDCKE is satisfied.

Figure 145 - Refresh entry to Power-Down Entry

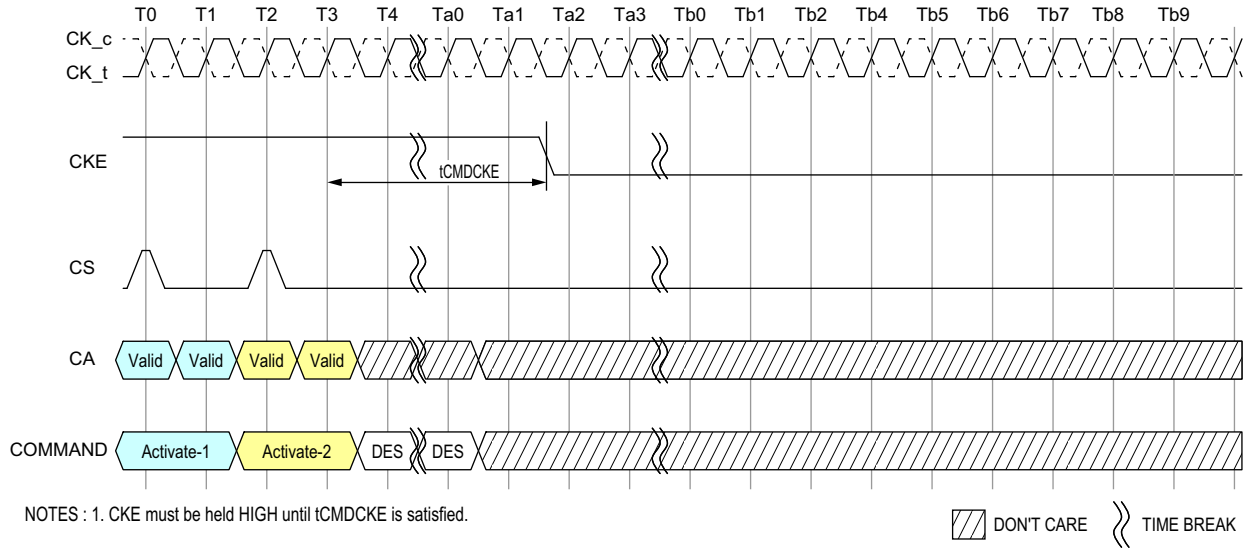

Figure 146 - Activate Command to Power-Down Entry

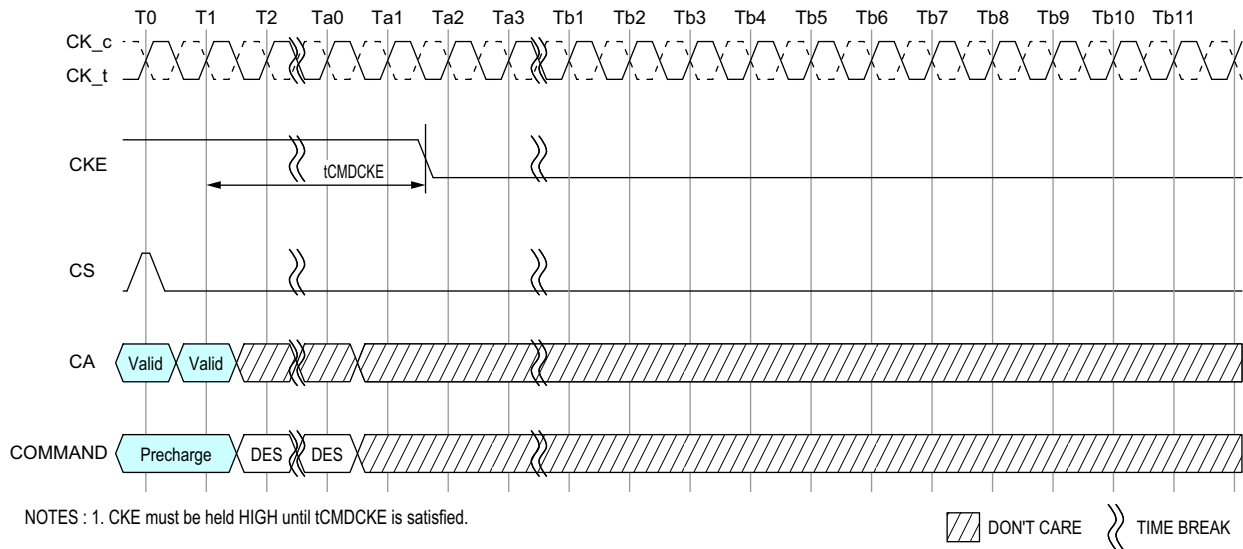
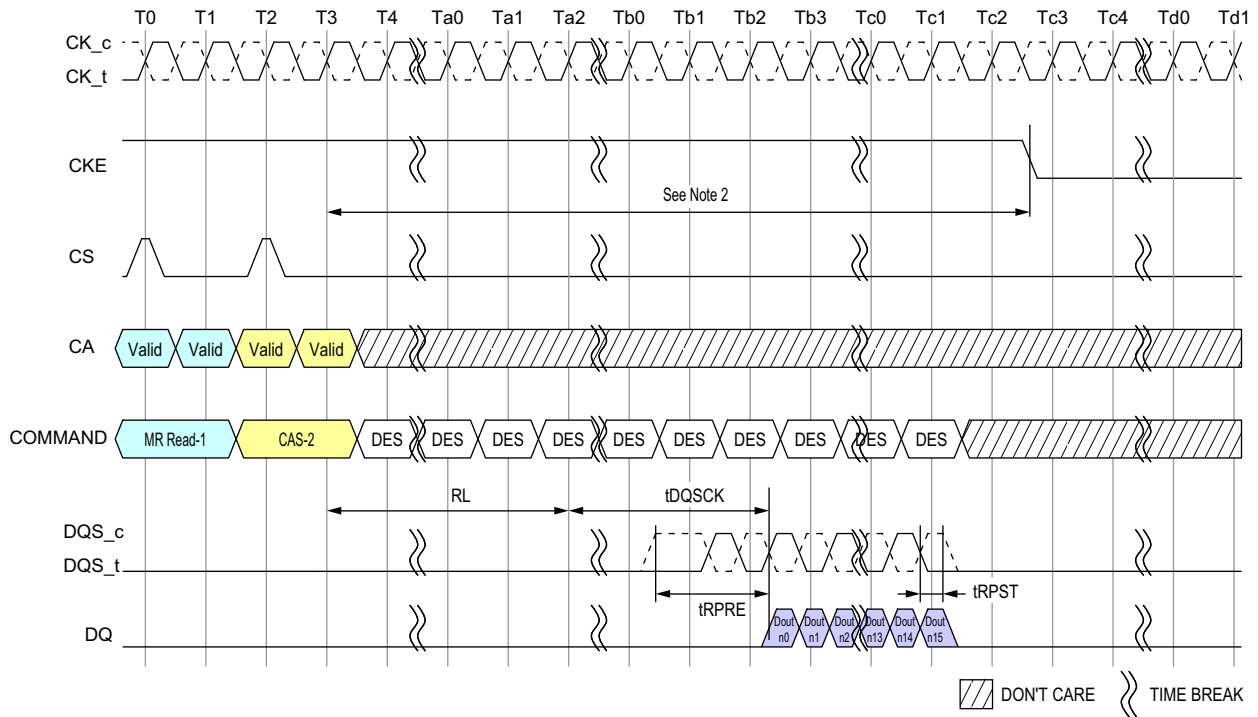
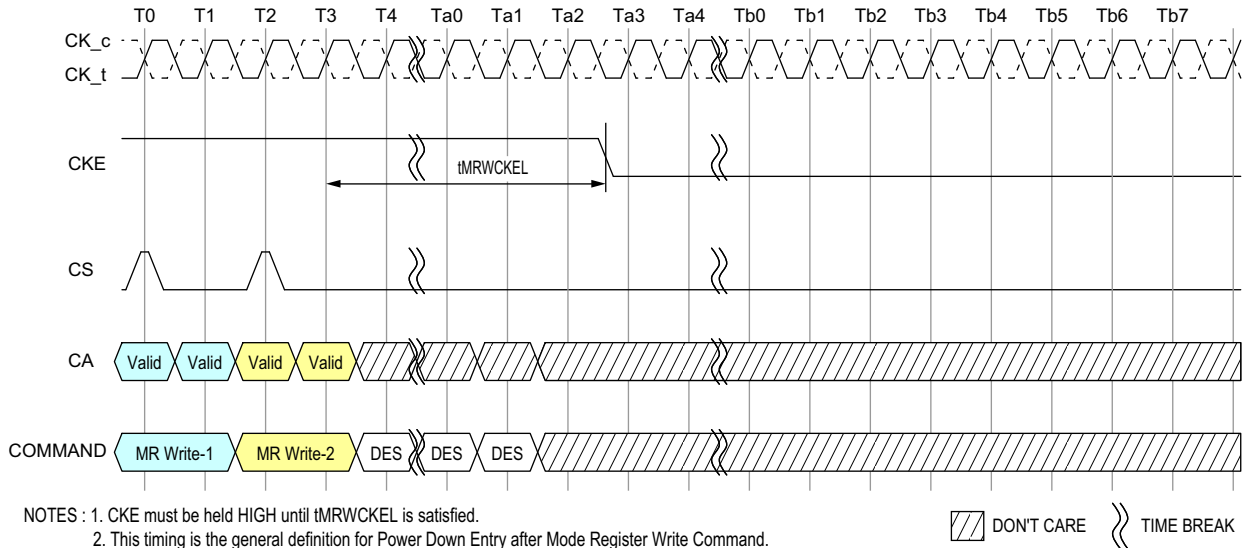

Figure 147 - Precharge Command to Power-Down Entry



- NOTES : 1. CKE must be held HIGH until the end of the burst operation.
 2. Minimum Delay time from Mode Register Read Command to falling edge of CKE signal is as follows:
 Read Post-amble = 0.5nCK : MR1 OP[7]=[0] : $(RL \times tCK) + tDQSCK(Max) + ((BL/2) \times tCK) + 1tCK$
 Read Post-amble = 1.5nCK : MR1 OP[7]=[1] : $(RL \times tCK) + tDQSCK(Max) + ((BL/2) \times tCK) + 2tCK$

Figure 148 - Mode Register Read to Power-Down Entry



- NOTES : 1. CKE must be held HIGH until tMRWCKEL is satisfied.
 2. This timing is the general definition for Power Down Entry after Mode Register Write Command.
 When a Mode Register Write Command changes a parameter or starts an operation that requires special timing longer than tMRWCKEL, that timing must be satisfied before CKE is driven low.
 Changing the Vref(DQ) value is one example, in this case the appropriate Vref_time-Short/Middle/Long must be satisfied.

Figure 149 - MRW to Power-Down Entry

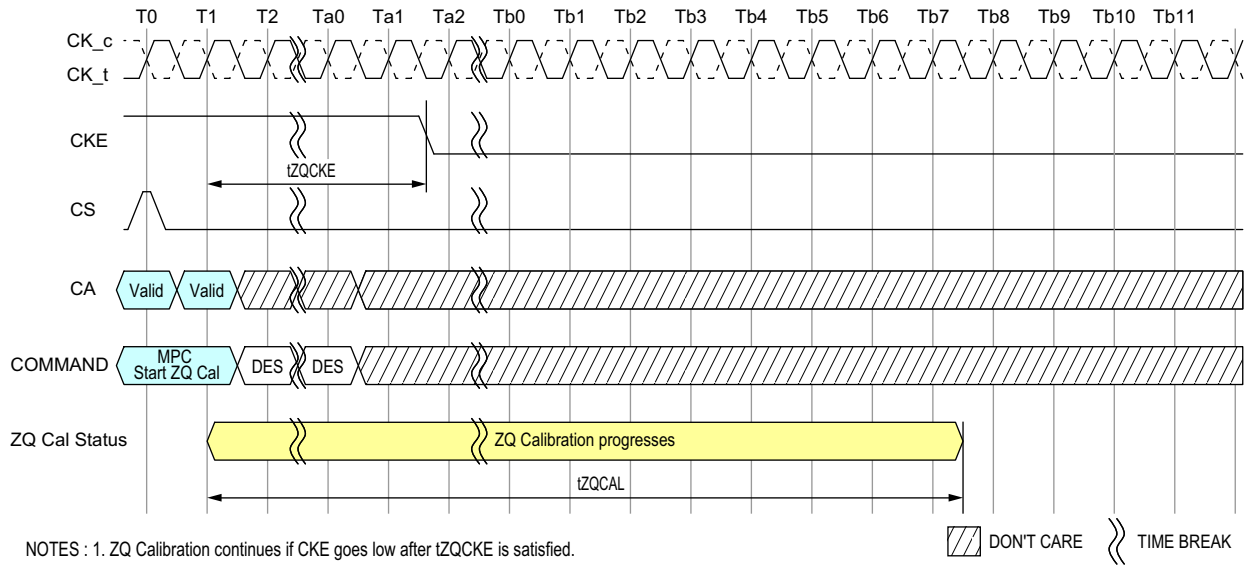

Figure 150 - MPC ZQCAL_start to Power-Down Entry

Table 92 - Power Down AC Timing

Parameter	Symbol	min max	533	1066	1600	2133	2667	3200	3733	4266	Unit	Note
CKE minimum pulse width (HIGH and LOW pulse width)	tCKE	min	Max(7.5ns,4nCK)								-	
Delay from valid command to CKE input LOW	tCMDCKE	min	Max(1.75ns,3nCK)								ns	1
Valid Clock Requirement after CKE Input low	tCKELCK	min	Max(5ns,5nCK)								ns	1
Valid CS Requirement before CKE Input Low	tCSCKE	min	1.75								ns	
Valid CS Requirement after CKE Input low	tCKELCS	min	Max(5ns, 5nCK)								ns	
Valid Clock Requirement before CKE Input High	tCKCKEH	min	Max(1.75ns, 3nCK)								ns	1
Exit power- down to next valid command delay	tXP	min	Max(7.5ns, 5nCK)								ns	1
Valid CS Requirement before CKE Input High	tCSCKEH	min	1.75								ns	
Valid CS Requirement after CKE Input High	tCKEHCS	min	Max(7.5ns, 5nCK)								ns	
Valid Clock and CS Requirement after CKE Input low after MRW Command	tMRWCKEL	min	Max(14ns, 10nCK)								ns	1
Valid Clock and CS Requirement after CKE Input low after ZQ Calibration Start Command	tZQCKE	min	Max(1.75ns, 3nCK)								ns	1

Notes

- Delay time has to satisfy both analog time(ns) and clock count(nCK).
For example, tCMDCKE will not expire until CK has toggled through at least 3 full cycles (3 *tCK) and 1.75ns has transpired. The case which 3nCK is applied to is shown below.

For example, tCMDCKE will not expire until CK has toggled through at least 3 full cycles (3 *tCK) and 1.75ns has transpired. The case which 3nCK is applied to is shown In Figure below.

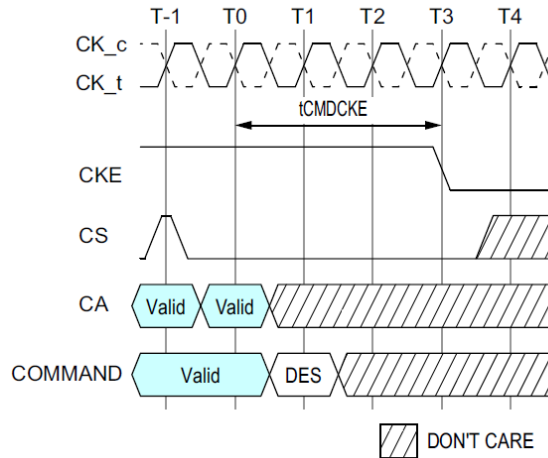

Figure 151 - tCMDCKE Timing

2.46. Input clock stop and frequency change

LPDDR4 SDRAMs support input clock frequency change during CKE LOW under the following conditions:

- $t_{CK(ABS)min}$ is met for each clock cycle;
- Refresh requirements apply during clock frequency change;
- During clock frequency change, only REFab or REFpb commands may be executing;
- Any Activate or Precharge commands have executed to completion prior to changing the frequency;
- The related timing conditions (t_{RCD} , t_{RP}) have been met prior to changing the frequency;
- The initial clock frequency shall be maintained for a minimum of t_{CKELCK} after CKE goes LOW;
- The clock satisfies $t_{CH(ABS)}$ and $t_{CL(ABS)}$ for a minimum of t_{CKCKEH} prior to CKE going HIGH

After the input clock frequency is changed and CKE is held HIGH, additional MRW commands may be required to set the WR, RL etc. These settings may need to be adjusted to meet minimum timing requirements at the target clock frequency.

LPDDR4 devices support clock stop during CKE LOW under the following conditions:

- CK_t and CK_c are don't care during clock stop;
- Refresh requirements apply during clock stop;
- During clock stop, only REFab or REFpb commands may be executing;
- Any Activate or Precharge commands have executed to completion prior to stopping the clock;
- The related timing conditions (t_{RCD} , t_{RP}) have been met prior to stopping the clock;
- The initial clock frequency shall be maintained for a minimum of t_{CKELCK} after CKE goes LOW;
- The clock satisfies $t_{CH(ABS)}$ and $t_{CL(ABS)}$ for a minimum of t_{CKCKEH} prior to CKE going HIGH

LPDDR4 devices support input clock frequency change during CKE HIGH under the following conditions:

- $t_{CK(ABS)min}$ is met for each clock cycle;
- Refresh requirements apply during clock frequency change;
- Any Activate, Read, Read with auto Precharge, Write, Write with auto Precharge, MPC(WRFIFO,RDFIFO, RDDQCAL), Precharge, Mode Register Write, or Mode Register Read commands must have executed to completion, including any associated data bursts prior to changing the frequency;
- The related timing conditions (t_{RCD} , t_{WR} , t_{RP} , t_{MRW} , t_{MRR} , etc.) have been met prior to changing the frequency;
- CS shall be held LOW during clock frequency change;
- During clock frequency change, only REFab or REFpb commands may be executing;
- The LPDDR4 SDRAM is ready for normal operation after the clock satisfies $t_{CH(ABS)}$ and $t_{CL(ABS)}$ for a minimum of $2 \cdot t_{CK} + t_{XP}$.

After the input clock frequency is changed, additional MRW commands may be required to set the WR, RL etc. These settings may need to be adjusted to meet minimum timing requirements at the target clock frequency.

LPDDR4 devices support clock stop during CKE HIGH under the following conditions:

- CK_t is held LOW and CK_c is held HIGH during clock stop;
- CS shall be held LOW during clock stop;
- Refresh requirements apply during clock stop;
- During clock stop, only REFab or REFpb commands may be executing;
- Any Activate, Read, Write, MPC(WRFIFO,RDFIFO,RDDQCAL), Precharge, Mode Register Write or Mode Register Read commands must have executed to completion, including any associated data bursts and extra 4 clock cycles must be provided prior to stopping the clock;
- The related timing conditions (tRCD, tWR, tRP, tMRW, tMRR, tZQLAT, etc.) have been met prior to stopping the clock;
- Read with auto pre-charge and write with auto pre-charge commands need extra 4 clock cycles in addition to the related timing constraints, nWR and nRTP, to complete the operations.
- REFab, REFpb, SRE, SRX and MPC(Zqcal Start) commands are required to have 4 additional clocks prior to stopping the clock same as CKE=L case.
- The LPDDR4 SDRAM is ready for normal operation after the clock is restarted and satisfies tCH(abs) and tCL(abs) for a minimum of $2 \cdot tCK + tXP$.

2.47. Truth Tables

Operation or timing that is not specified is illegal, and after such an event, in order to guarantee proper operation, the LPDDR4 device must be reset or power-cycled and then restarted through the specified initialization sequence before normal operation can continue.

CKE signal has to be held High when the commands listed in the command truth table input.

2.47.1. Command Truth Table

Command	SDR Command Pins	SDR CA Pins (6)						CK_t edge	Notes
	CS	CA0	CA1	CA2	CA3	CA4	CA5		
Deselect (DES)	L	X						R1	1,2
Multi Purpose Command (MPC)	H	L	L	L	L	L	OP6	R1	1,9
	L	OP0	OP1	OP2	OP3	OP4	OP5	R2	
Precharge (Per Bank, All Bank)	H	L	L	L	L	H	AB	R1	1,2,3,4
	L	BA0	BA1	BA2	V	V	V	R2	
Refresh (Per Bank, All Bank)	H	L	L	L	H	L	AB	R1	1,2,3,4
	L	BA0	BA1	BA2	V	V	V	R2	
Self Refresh Entry	H	L	L	L	H	H	V	R1	1,2
	L	V						R2	
Write-1	H	L	L	H	L	L	BL	R1	1,2,3,6,7,9
	L	BA0	BA1	BA2	V	C9	AP	R2	
Self Refresh Exit	H	L	L	H	L	H	V	R1	1,2
	L	V						R2	
Mask Write-1	H	L	L	H	H	L	L	R1	1,2,3,5,6,9
	L	BA0	BA1	BA2	V	C9	AP	R2	
RFU	H	L	L	H	H	H	V	R1	1,2
	L	V						R2	
Read-1	H	L	H	L	L	L	BL	R1	1,2,3,6,7,9
	L	BA0	BA1	BA2	V	C9	AP	R2	
CAS-2 (Write-2, Mask Write-2, Read-2 or MRR-2, MPC)	H	L	H	L	L	H	C8	R1	1,8,9
	L	C2	C3	C4	C5	C6	C7	R2	
RFU	H	L	H	L	H	L	V	R1	1,2
	L	V						R2	
RFU	H	L	H	L	H	H	V	R1	1,2
	L	V						R2	
MRW-1	H	L	H	H	L	L	OP7	R1	1,11
	L	MA0	MA1	MA2	MA3	MA4	MA5	R2	
MRW-2	H	L	H	H	L	H	OP6	R1	1,11
	L	OP0	OP1	OP2	OP3	OP4	OP5	R2	

Command	SDR Command Pins	SDR CA Pins (6)						CK_t edge	Notes
	CS	CA0	CA1	CA2	CA3	CA4	CA5		
MRR-1	H	L	H	H	H	L	V	R1	1,2,12
	L	MA0	MA1	MA2	MA3	MA4	MA5	R2	
RFU	H	L	H	H	H	H	V	R1	1,2
	L	V						R2	
Activate-1	H	H	L	R12	R13	R14	R15	R1	1,2,3,10
	L	BA0	BA1	BA2	R16	R10	R11	R2	
Activate-2	H	R17	R18	R6	R7	R8	R9	R1	1,10,13
	L	R0	R1	R2	R3	R4	R5	R2	

Notes

- All LPDDR4 commands except for Deselect are 2 clock cycle long and defined by states of CS and CA[5:0] at the first rising edge of clock. Deselect command is 1 clock cycle long.
- "V" means "H" or "L" (a defined logic level). "X" means don't care in which case CA[5:0] can be floated.
- Bank addresses BA[2:0] determine which bank is to be operated upon.
- AB "HIGH" during Precharge or Refresh command indicates that command must be applied to all banks and bank address is a don't care.
- Mask Write-1 command supports only BL 16. For Mask Write-1 command, CA5 must be driven LOW on first rising clock cycle (R1).
- AP "HIGH" during Write-1, Mask Write-1 or Read-1 commands indicates that an auto-precharge will occur to the bank associated with the Write, Mask Write or Read command.
- If Burst Length on-the-fly is enabled, BL "HIGH" during Write-1 or Read-1 command indicates that Burst Length should be set on-the-fly to BL=32. BL "LOW" during Write-1 or Read-1 command indicates that Burst Length should be set on-the-fly to BL=16. If Burst Length on-the-fly is disabled, then BL must be driven to defined logic level "H" or "L".
- For CAS-2 commands (Write-2 or Mask Write-2 or Read-2 or MRR-2 or MPC (Only Write FIFO, Read FIFO & Read DQ Calibration), C[1:0] are not transmitted on the CA[5:0] bus and are assumed to be zero. Note that for CAS-2 Write-2 or CAS-2 Mask Write-2 command, C[3:2] must be driven LOW.
- Write-1 or Mask Write-1 or Read-1 or Mode Register Read-1 or MPC (Only Write FIFO, Read FIFO & Read DQ Calibration) command must be immediately followed by CAS-2 command consecutively without any other command in between. Write-1 or Mask Write-1 or Read-1 or Mode Register Read-1 or MPC (Only Write FIFO, Read FIFO & Read DQ Calibration) command must be issued first before issuing CAS-2 command. MPC (Only Start & Stop DQS Oscillator, Start & Latch ZQ Calibration) commands do not require CAS-2 command; they require two additional DES or NOP commands consecutively before issuing any other commands.
- Activate-1 command must be immediately followed by Activate-2 command consecutively without any other command in between. Activate-1 command must be issued first before issuing Activate-2 command. Once Activate-1 command is issued, Activate-2 command must be issued before issuing another Activate-1 command.
- MRW-1 command must be immediately followed by MRW-2 command consecutively without any other command in between. MRW-1 command must be issued first before issuing MRW-2 command.
- MRR-1 command must be immediately followed by CAS-2 command consecutively without any other command in between. MRR-1 command must be issued first before issuing CAS-2 command.
- In case of the densities which not to use R17 and R18 as row address, R17 and R18 must both be driven High for every ACT-2 command to maintain backward compatibility.

2.48. TRR Mode - Target Row Refresh

A LPDDR4 SDRAM's row has a limited number of times a given row can be accessed within a refresh period ($t_{REFW} * 2$) prior to requiring adjacent rows to be refreshed. The Maximum Activate Count (MAC) is the maximum number of activates that a single row can sustain within a refresh period before the adjacent rows need to be refreshed. The row receiving the excessive activates is the Target Row (TRn), the adjacent rows to be refreshed are the victim rows. When the MAC limit is reached on TRn, either the LPDDR4 SDRAM receive all ($R * 2$) Refresh Commands before another row activate is issued, or the LPDDR4 SDRAM should be placed into Targeted Row Refresh (TRR) mode. The TRR Mode will re-refresh the rows adjacent to the TRn that encountered tMAC limit.

If LPDDR4 SDRAM supports Unlimited MAC value: MR24 [OP2:0=000] and MR24 [OP3=1], Target Row Refresh operation is not required. Even though LPDDR4 SDRAM allows to set MR24 [OP7=1]: TRR mode enable, in this case LPDDR4 SDRAM's behavior is vendor specific. For example, a certain LPDDR4 SDRAM may ignore MRW command for entering/exiting TRR mode or a certain SDRAM may support commands related TRR mode. See vendor device datasheets for details about TRR mode definition at supporting Unlimited MAC value case.

There could be a maximum of two target rows to a victim row in a bank. The cumulative value of the activates from the two target rows on a victim row in a bank should not exceed MAC value as well.

MR24 fields required to support the new TRR settings. Setting MR24 [OP7=1] enables TRR Mode and setting MR24 [OP7=0] disables TRR Mode. MR24 [OP6:OP4] defines which bank (BAn) the target row is located in (See MR24 table for details).

The TRR mode must be disabled during initialization as well as any other LPDDR4 SDRAM calibration modes. The TRR mode is entered from a DRAM Idle State, once TRR mode has been entered, no other Mode Register commands are allowed until TRR mode is completed, except setting MR24 [OP7=0] to interrupt and reissue the TRR mode is allowed.

When enabled; TRR Mode is self-clearing; the mode will be disabled automatically after the completion of defined TRR flow; after the 3rd BAn precharge has completed plus tMRD. Optionally the TRR mode can also be exited via another MRS command at the completion of TRR by setting MR24 [OP7=0]; if the TRR is exited via another MRS command, the value written to MR24 [OP6:OP4] are don't cares.

2.48.1. TRR Mode Operation

1. The timing diagram in Figure "TRR Mode Timing Example" depicts TRR mode. The following steps must be performed when TRR mode is enabled. This mode requires all three ACT (ACT1, ACT2 and ACT3) and three corresponding PRE commands (PRE1, PRE2 and PRE3) to complete TRR mode. A Precharge All (PREA) commands issued while LPDDR4 SDRAM is in TRR mode will also perform precharge to BAn and counts towards a PREn command.
2. Prior to issuing the MRW command to enter TRR mode, the SDRAM should be in the idle state. A MRW command must be issued with MR24 [OP7=1] and MR24 [OP6:OP4] defining the bank in which the targeted row is located. All other MR24 bits should remain unchanged.
3. No activity is to occur in the DRAM until tMRD has been satisfied. Once tMRD has been satisfied, the only commands to BAn allowed are ACT and PRE until the TRR mode has been completed.
4. The first ACT to the BAn with the TRn address can now be applied, no other command is allowed at this point. All other banks must remain inactive from when the first BAn ACT command is issued until $[(1.5 * tRAS) + tRP]$ is satisfied.
5. After the first ACT to the BAn with the TRn address is issued, a PRE to BAn is to be issued $(1.5 * tRAS)$ later; and then followed tRP later by the second ACT to the BAn with the TRn address. Once the 2nd activate to the BAn is issued, nonBAn banks are allowed to have activity.
6. After the second ACT to the BAn with the TRn address is issued, a PRE to BAn is to be issued tRAS later and then followed tRP later by the third ACT to the BAn with the TRn address.
7. After the third ACT to the BAn with the TRn address is issued, a PRE to BAn would be issued tRAS later; and once the third PRE has been issued, nonBAn bank groups are not allowed to have activity until TRR mode is exited. The TRR mode is completed once tRP plus tMRD is satisfied.
8. TRR mode must be completed as specified to guarantee that adjacent rows are refreshed. Any-time the TRR mode is interrupted and not completed, the interrupted TRR Mode must be cleared and then subsequently performed again. To clear an interrupted TRR mode, an MR24 change is required with setting MR24 [OP7=0], MR24 [OP6:OP4] are don't care, followed by three PRE to BAn, tRP time in between each PRE command. The complete TRR sequence (Steps 2-7) must be then re-issued and completed to guarantee that the adjacent rows are refreshed.
9. Refresh command to the LPDDR4 SDRAM or entering Self-Refresh mode is not allowed while the DRAM is in TRR mode.

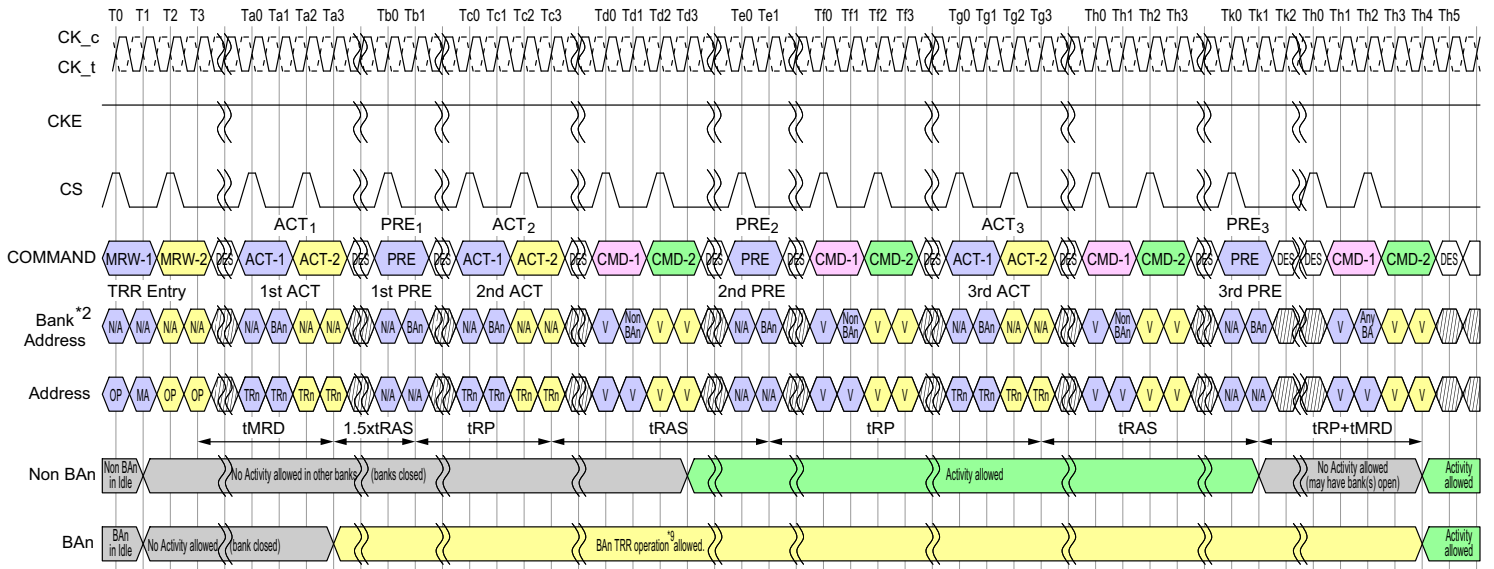

Note

1. TRn is targeted row.
2. Bank BA_n represents the bank in which the targeted row is located.
3. TRR mode self-clears after tMRD + tRP measured from 3rd BA_n precharge PRE3 at clock edge Th4.
4. TRR mode or any other activity can be re-engaged after tRP + tMRD from 3rd BA_n precharge PRE3. PRE_{ALL} also counts if issued instead of PRE_n. TRR mode is cleared by DRAM after PRE3 to the BA_n bank.
5. Activate commands to BA_n during TRR mode do not provide refreshing support, i.e. the Refresh counter is unaffected.
6. The DRAM must restore the degraded row(s) caused by excessive activation of the targeted row (TRn) necessary to meet refresh requirements.
7. A new TRR mode must wait tMRD+tRP time after the third precharge.
8. BA_n may not be used with any other command.
9. ACT and PRE are the only allowed commands to BA_n during TRR Mode.
10. Refresh commands are not allowed during TRR mode.
11. All DRAM timings are to be met by DRAM during TRR mode such as tFAW. Issuing of ACT1, ACT2 and ACT3 counts towards tFAW budget.

 DONT CARE  TIME BREAK

Figure 152 - TRR Mode Timing Example

2.49. Post Package Repair - PPR

LPDDR4 supports Fail Row address repair as an optional feature and it is readable through MR25 OP[7:0].

PPR provides simple and easy repair method in the system and Fail Row address can be repaired by the electrical programming of Electrical-fuse scheme.

With PPR, LPDDR4 can correct 1Row per Bank.

Electrical-fuse cannot be switched back to un-fused states once it is programmed. The controller should prevent unintended the PPR mode entry and repair.

2.49.1. Fail Row Address Repair

The following is procedure of PPR.

1. Before entering 'PPR' mode, All banks must be Precharged
2. Enable PPR using MR4 bit "OP4=1" and wait tMRD
3. Issue ACT command with Fail Row address
4. Wait tPGM to allow DRAM repair target Row Address internally then issue PRE
5. Wait tPGM_Exit after PRE which allow DRAM to recognize repaired Row address RAn
6. Exit PPR with setting MR4 bit "OP4=0"
7. Issue RESET command after tPGMPST
8. Repeat steps in '3.3.2 Reset Initialization with Stable Power' section
9. In More than one fail address repair case, Repeat Step 2 to 8

Once PPR mode is exited, to confirm if target row is repaired correctly, host can verify by writing data into the target row and reading it back after PPR exit with MR4 [OP4=0] and tPGMPST.

The following Timing diagram show PPR related MR bits and its operation.

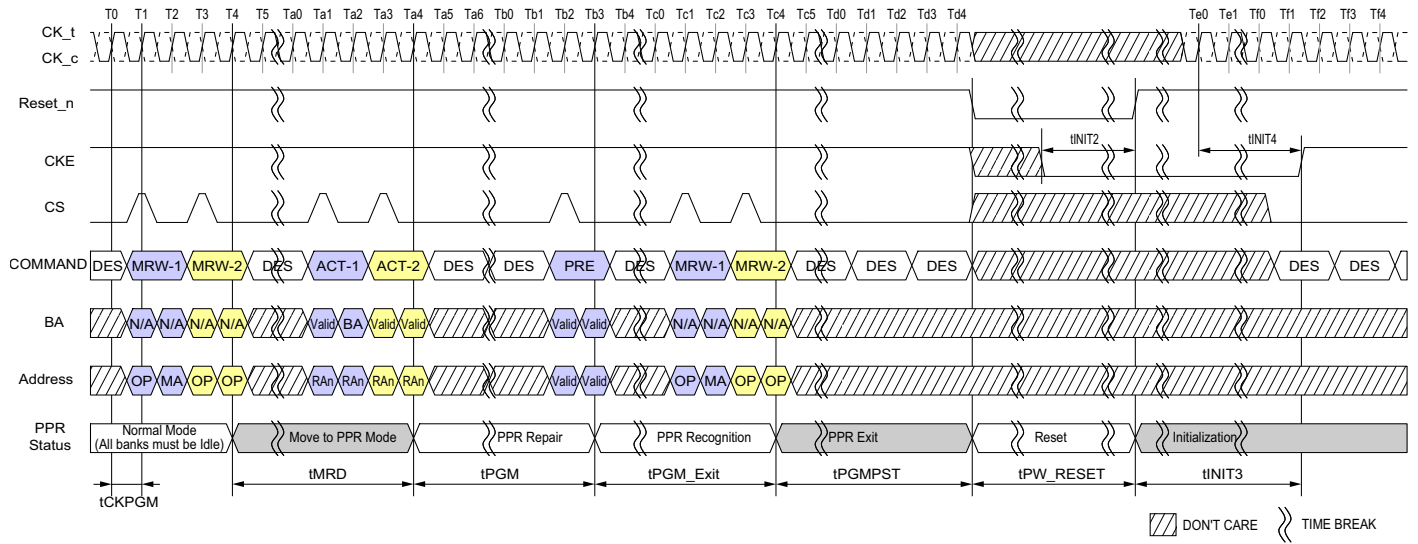

Figure 153 - PPR Timing

Notes

1. During tPGM, any other commands (including refresh) are not allowed on each die.
2. With one PPR command, only one row can be repaired at one time per die.
3. RESET command is required at the end of every PPR procedure.
4. During PPR, memory contents is not refreshed and may be lost.
5. Assert Reset_n below 0.2 X V_{DD2}. Reset_n needs to be maintained LOW for minimum tPW_RESET. CKE must be pulled LOW at least 10ns before deasserting Reset_n.
6. After RESET command, follow steps 4 to 10 in 'Voltage Ramp and Device Initialization' section.

Table 93 - PPR Timing Parameters

Parameter	Symbol	min	max	Unit	Note
PPR Programming Time	tPGM	1000	-	ms	
PPR Exit Time	tPGM_Exit	15	-	ns	
New Address Setting time	tPGMPST	50	-	us	
PPR Programming Clock	tCKPGM	1.25	-	ns	

3. Absolute Maximum DC Ratings

Stresses greater than those listed may cause permanent damage to the device.

This is a stress rating only, and functional operation of the device at these or any other conditions above those indicated in the operational sections of this specification is not implied. Exposure to absolute maximum rating conditions for extended periods may affect reliability.

Table 94 - Absolute Maximum DC Ratings

Parameter	Symbol	Min	Max	Unit	Notes
VDD1 supply voltage relative to VSS	VDD1	-0.4	2.1	V	1
VDD2 supply voltage relative to VSS	VDD2	-0.4	1.5	V	1
VDDQ supply voltage relative to VSSQ	VDDQ	-0.4	1.5	V	1
Voltage on Any Pin except VDD1 relative to VSS	VIN, VOUT	-0.4	1.5	V	
Storage Temperature	TSTG	-55	125	°C	2

Notes

1. See the section "Power-up, Initialization, and Power-off" for information about relationships between power supplies.
2. Storage Temperature is the case surface temperature on the center/top side of the device. For the measurement conditions, please refer to JESD51-2 standard.

4. AC and DC Operating Conditions

4.1. Recommended DC Operating Conditions

Parameter	Symbol	Min	Typ	Max	Unit	Notes
Core Power 1	VDD1	1.70	1.80	1.95	V	1,2
Core Power 2 & CA Power	VDD2	1.06	1.10	1.17	V	1,2,3
I/O Buffer Power	VDDQ	0.57	0.60	0.65	V	2,3,4,5

Notes

- VDD1 uses significantly less current than VDD2.
- The voltage range is for DC voltage only. DC is defined as the voltage supplied at the DRAM and is inclusive of all noise up to 20MHz at the DRAM package ball.
- The voltage noise tolerance from DC to 20MHz exceeding a pk-pk tolerance of 45mV at the DRAM ball is not included in the TdIVW.
- VDDQ (max) may be extended to 0.67 V as an option in case the operating clock frequency is equal or less than 800 Mhz.
- Pull up, pull down and ZQ calibration tolerance spec is valid only in normal VDDQ tolerance range (0.57V - 0.65V).

4.2. Input Leakage Current

Parameter	Symbol	Min	Max	Unit	Notes
Input Leakage current	I_L	-4	4	uA	1,2

Notes

- For CK_t, CK_c, CKE, CS, CA, ODT_CA and RESET_n. Any input $0V \leq V_{IN} \leq VDD2$ (All other pins not under test = 0V).
- CA ODT is disabled for CK_t, CK_c, CS, and CA.

4.3. Input/Output Leakage Current

Parameter	Symbol	Min	Max	Unit	Notes
Input/Output Leakage current	I_{OZ}	-5	5	uA	1,2

Notes

- For DQ, DQS_t, DQS_c and DMI. Any I/O $0V \leq V_{OUT} \leq VDDQ$.
- I/Os status are disabled: High Impedance and ODT Off.

4.4. Operating Temperature

Parameter	Symbol	Min	Max	Unit	Note
Operating Temperature	Standard	-25	85	°C	1
	Extended	85	105		1

Notes

- Operating Temperature is the case surface temperature on the center-top side of the LPDDR4 device. For the measurement conditions, please refer to JESD51-2 standard.
- Some applications require operation of LPDDR4 in the maximum temperature conditions in the Elevated Temperature Range between 85°C and 105°C case temperature. For LPDDR4 devices, derating may be necessary to operate in this range. See MR4 on the section "Mode Register".
- Either the device case temperature rating or the temperature sensor (See the section of "Temperature Sensor") may be used to set an appropriate refresh rate, determine the need for AC timing de-rating and/or monitor the operating temperature. When using the temperature sensor, the actual device case temperature may be higher than the TOPER rating that applies for the Standard or Elevated Temperature Ranges. For example, TCASE may be above 85°C when the temperature sensor indicates a temperature of less than 85°C.

5. AC and DC Input Measurement Levels

5.1. 1.1V High speed LVCMOS (HS_LLVC MOS)

5.1.1. Standard specifications

All voltages are referenced to ground except where noted.

5.1.2. DC electrical characteristics

5.1.2.1. Input Level for CKE

This definition applies to CKE_A/B.

Table 95 - LPDDR4 Input level for CKE

Parameter	Symbol	Min	Max	Unit	Notes
Input high level (AC)	VIH(AC)	0.75*VDD2	VDD2+0.2	V	1
Input low level (AC)	VIL(AC)	-0.2	0.25*VDD2	V	1
Input high level (DC)	VIH(DC)	0.65*VDD2	VDD2+0.2	V	
Input low level (DC)	VIL(DC)	-0.2	0.35*VDD2	V	

Notes:

1. Refer to LPDDR4 AC Over/Undershoot section.

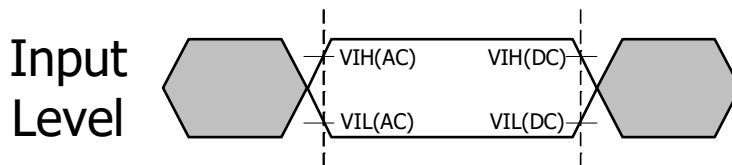

Note:

1. AC level is guaranteed transition point
2. DC level is hysteresis

 Don't Care

Figure 154 - Input AC timing definition for CKE

5.1.2.2. LPDDR4 Input Level for Reset_n and ODT_CA

This definition applies to Reset_n and ODT_CA.

Table 96 - LPDDR4 Input AC timing definition for Reset_n and ODT_CA

Parameter	Symbol	Min	Max	Unit	Notes
Input high level	VIH	0.8*VDD2	VDD2+0.2	V	1
Input low level	VIL	-0.2	0.20*VDD2	V	1

Notes:

1. Refer to LPDDR4 AC Over/Undershoot section.

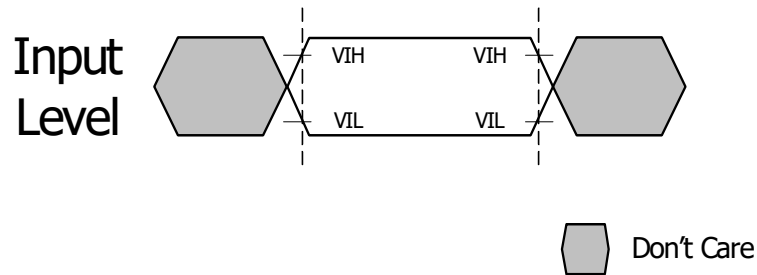

Figure 155 - Input AC timing definition

5.1.3. AC Over/Undershoot

5.1.3.1. LPDDR4 AC Over/Undershoot

Table 97 - LPDDR4 AC Over/Undershoot

Parameter	Specification	Units
Maximum peak amplitude allowed for overshoot area	0.35	V
Maximum peak amplitude allowed for undershoot area	0.35	V
Maximum overshoot area above VDD/VDDQ	0.8	V-ns
Maximum undershoot area below VSS/VSSQ	0.8	V-ns

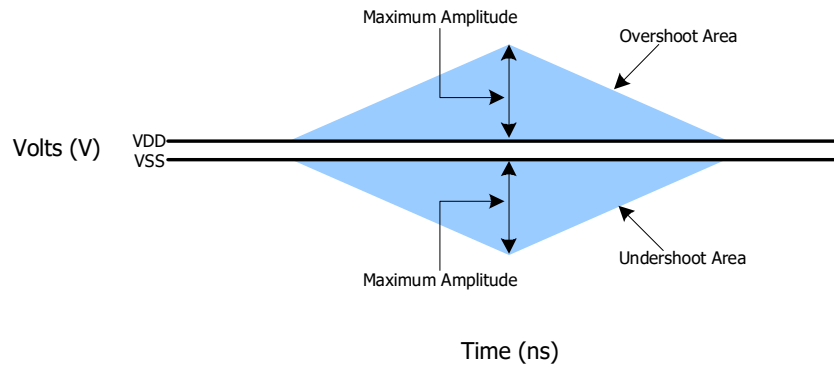

Figure 156 - AC Overshoot and Undershoot Definition for Address and Control Pins

5.2. Differential Input Voltage

5.2.1. Differential Input Voltage for CK

The minimum input voltage need to satisfy both V_{indiff_CK} and $V_{indiff_CK} / 2$ specification at input receiver and their measurement period is $1t_{CK}$. V_{indiff_CK} is the peak to peak voltage centered on 0 volts differential and $V_{indiff_CK} / 2$ is max and min peak voltage from 0V.

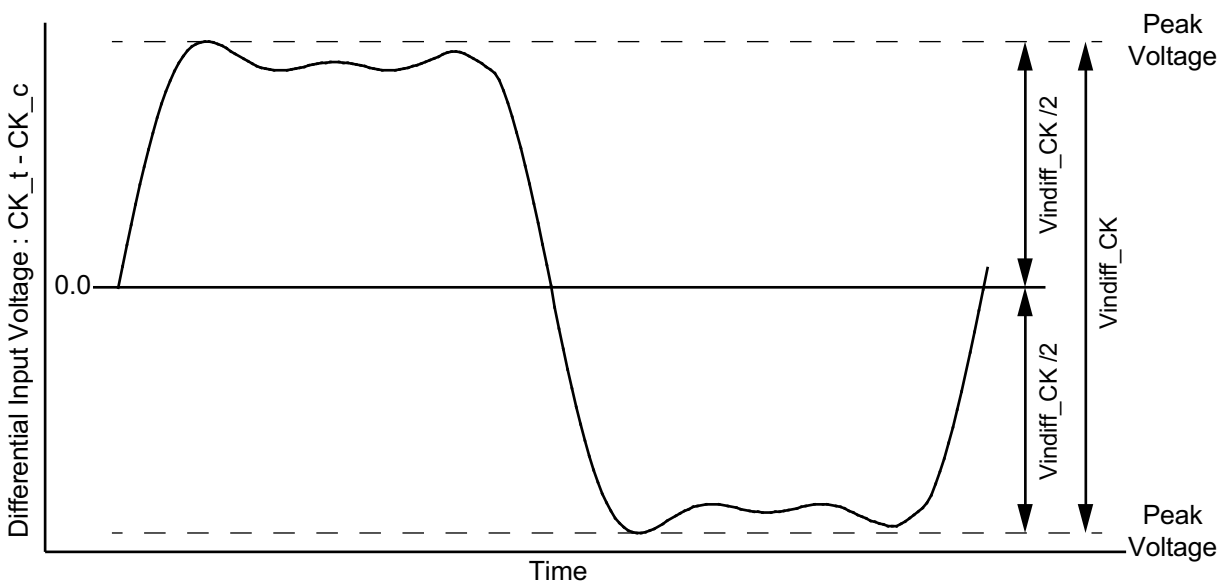

Figure 157 - CK Differential Input Voltage

Table 98 - CK differential input voltage

Parameter	Symbol	Data Rate						Unit	Notes
		1600/1867 ^a		2133/2400/3200		3733/4266			
		Min	Max	Min	Max	Min	Max		
CK differential input voltage	V_{indiff_CK}	420	-	380	-	360	-	mV	1

Notes:

1. The peak voltage of Differential CK signals is calculated in a following equation.

$$V_{indiff_CK} = (\text{Max Peak Voltage}) - (\text{Min Peak Voltage})$$

$$\text{Max Peak Voltage} = \text{Max}(f(t))$$

$$\text{Min Peak Voltage} = \text{Min}(f(t))$$

$$f(t) = V_{CK_t} - V_{CK_c}$$

a. The following requirements apply for DQ operating frequencies at or below 1333Gbps for all speed bins for the first column 1600/1867.

5.2.2. Peak voltage calculation method

The peak voltage of Differential Clock signals are calculated in a following equation.

$$VIH.DIFF.Peak\ Voltage = \text{Max}(f(t))$$

$$VIL.DIFF.Peak\ Voltage = \text{Min}(f(t))$$

$$f(t) = VCK_t - VCK_c$$

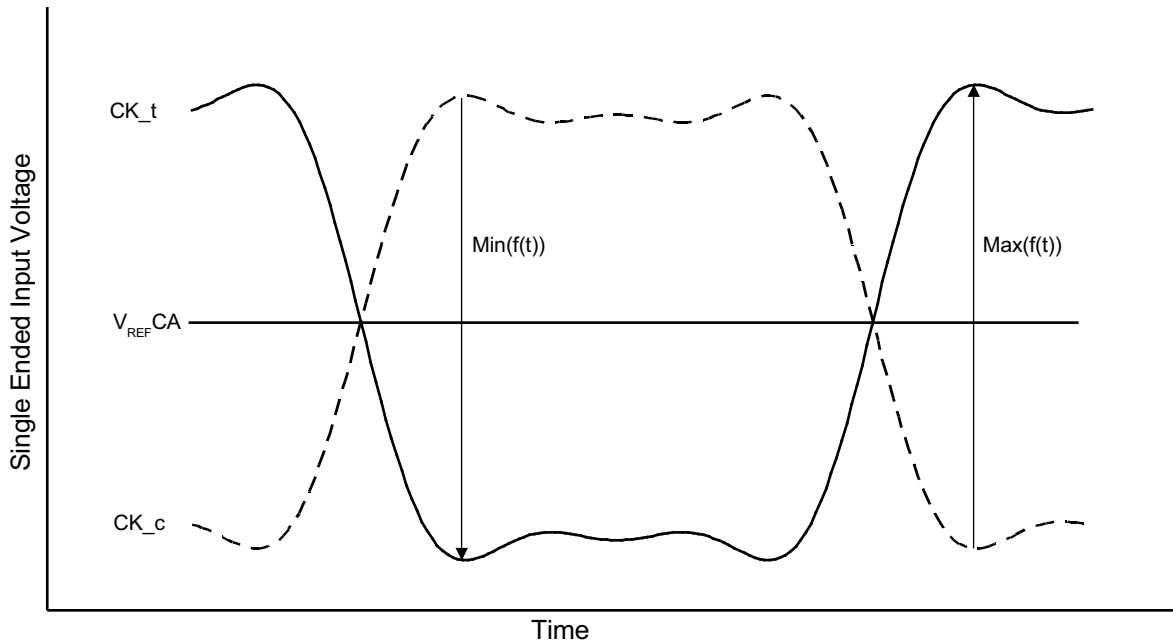

NOTES : 1. V_{REF_CA} is LPDDR4 SDRAM internal setting value by V_{REF} Training.

Figure 158 - Definition of differential Clock Peak Voltage

5.2.3. Single-Ended Input Voltage for Clock

The minimum input voltage need to satisfy both V_{inse_CK} , $V_{inse_CK_High/Low}$ specification at input receiver.

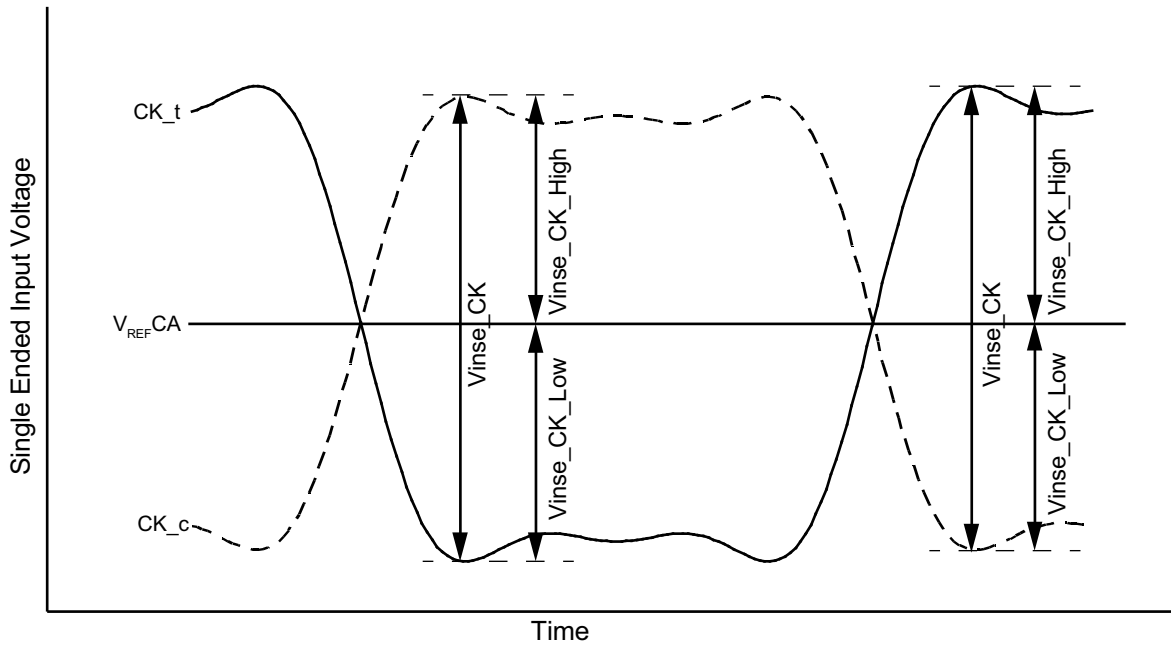

NOTES : 1. V_{REF_CA} is LPDDR4 SDRAM internal setting value by $V_{REF_Training}$.

Figure 159 - Clock Single-Ended Input Voltage

Table 99 - Clock Single-Ended input voltage

Parameter	Symbol	Data Rate						Unit	Note
		1600/1867 ^a		2133/2400/3200		3733/4266			
		Min	Max	Min	Max	Min	Max		
Clock Single-Ended input voltage	V_{inse_CK}	210	-	190	-	180	-	mV	
Clock Single-Ended input voltage High from V_{REF_DQ}	$V_{inse_CK_High}$	105	-	95	-	90	-	mV	
Clock Single-Ended input voltage Low from V_{REF_DQ}	$V_{inse_CK_Low}$	105	-	95	-	90	-	mV	

a. The following requirements apply for DQ operating frequencies at or below 1333Mbps for all speed bins for the first column 1600/1867.

5.2.4. Differential Input Slew Rate Definition for Clock

Input slew rate for differential signals (CK_t, CK_c) are defined and measured as shown in Figure below and the following Tables.

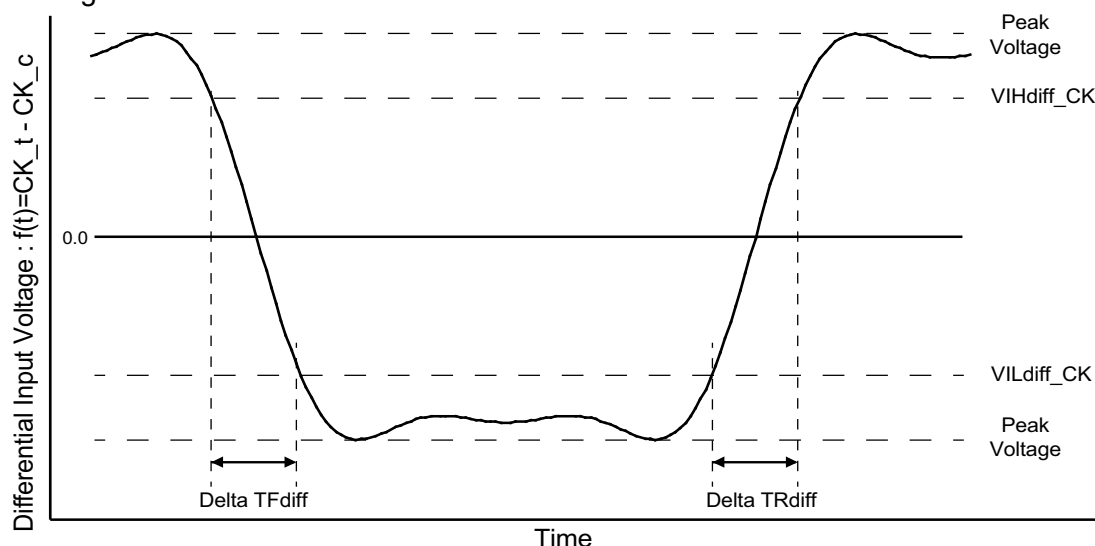

NOTES : 1. Differential signal rising edge from VILdiff_CK to VIHdiff_CK must be monotonic slope.
2. Differential signal falling edge from VIHdiff_CK to VILdiff_CK must be monotonic slope.

Figure 160 - Differential Input Slew Rate Definition for CK_t, CK_c

Table 100 - Differential Input Slew Rate Definition for CK_t, CK_c

Description	From	To	Defined by
	Differential input slew rate for rising edge(CK _t - CK _c)	VILdiff_CK	
Differential input slew rate for falling edge(CK _t - CK _c)	VIHdiff_CK	VILdiff_CK	$ VILdiff_CK - VIHdiff_CK /DeltaTFdiff$

Table 101 - Differential Input Level for CK_t, CK_c

Parameter	Symbol	Data Rate						Unit	Note
		1600/1867 ^a		2133/2400/3200		3733/4266			
		Min	Max	Min	Max	Min	Max		
Differential Input High	VIHdiff_CK	175	-	155	-	145	-	mV	
Differential Input Low	VILdiff_CK	-	-175	-	-155	-	-145	mV	

a. The following requirements apply for DQ operating frequencies at or below 1333Mbps for all speed bins for the first column 1600/1867.

Table 102 - Differential Input Slew Rate for CK_t, CK_c

Parameter	Symbol	Data Rate						Unit	Note
		1600/1867		2133/2400/3200		3733/4266			
		Min	Max	Min	Max	Min	Max		
Differential Input Slew Rate for Clock	SRIdiff_CK	2	14	2	14	2	14	V/ns	

5.2.5. Differential Input Cross Point Voltage

The cross point voltage of differential input signals (CK_t, CK_c) must meet the requirements in Table below. The differential input cross point voltage VIX is measured from the actual cross point of true and complement signals to the mid level.

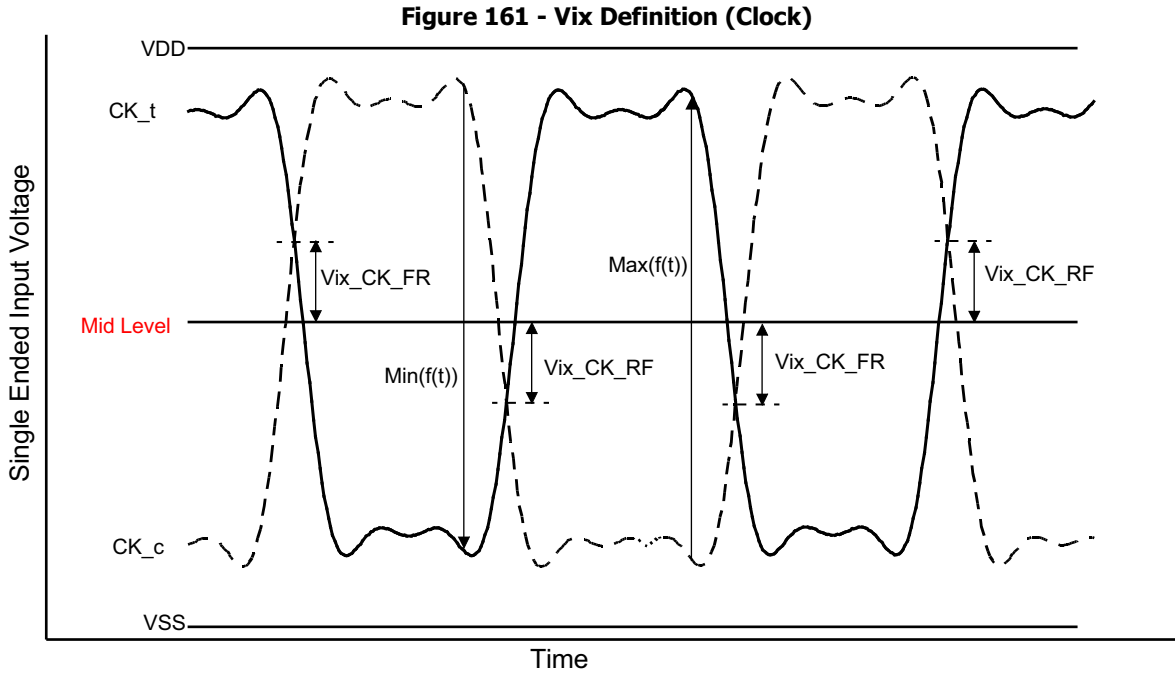

NOTES : 1. The base level of Vix_CK_FR/RF is V_{REF_CA} that is LPDDR4 SDRAM internal setting value by $V_{REF_Training}$.

Table 103 - Cross point voltage for differential input signals (Clock)

Parameter	Symbol	Data Rate						Unit	Note
		1600/1867 ^a		2133/2400/3200		3733/4266			
		Min	Max	Min	Max	Min	Max		
Clock Differential input cross point voltage ratio	Vix_CK_ratio	-	25	-	25	-	25	%	1,2

a. The following requirements apply for DQ operating frequencies at or below 1333Mbps for all speed bins for the first column 1600/1867.

- NOTE 1 Vix_CK_Ratio is defined by this equation: $Vix_CK_Ratio = Vix_CK_FR / |Min(f(t))|$
- NOTE 2 Vix_CK_Ratio is defined by this equation: $Vix_CK_Ratio = Vix_CK_RF / Max(f(t))$
- NOTE 3 Vix_CK_FR is defined as delta between cross point (CK_t fall, CK_c rise) to $Min(f(t))/2$.
Vix_CK_RF is defined as delta between cross point (CK_t rise, CK_c fall) to $Max(f(t))/2$.
- NOTE 4 In LPDDR4X un-terminated case, CK mid-level is calculated as :
High level = VDDQ, Low level = VSS, Mid-level = $VDDQ/2$.
In LPDDR4 un-terminated case, Mid-level must be equal or lower than 369mV (33.6% of VDD2).

5.2.6. Differential Input Voltage for DQS

The minimum input voltage need to satisfy both V_{indiff_DQS} and $V_{indiff_DQS} / 2$ specification at input receiver and their measurement period is $1UI(tCK/2)$. V_{indiff_DQS} is the peak to peak voltage centered on 0 volts differential and $V_{indiff_DQS} / 2$ is max and min peak voltage from 0V.

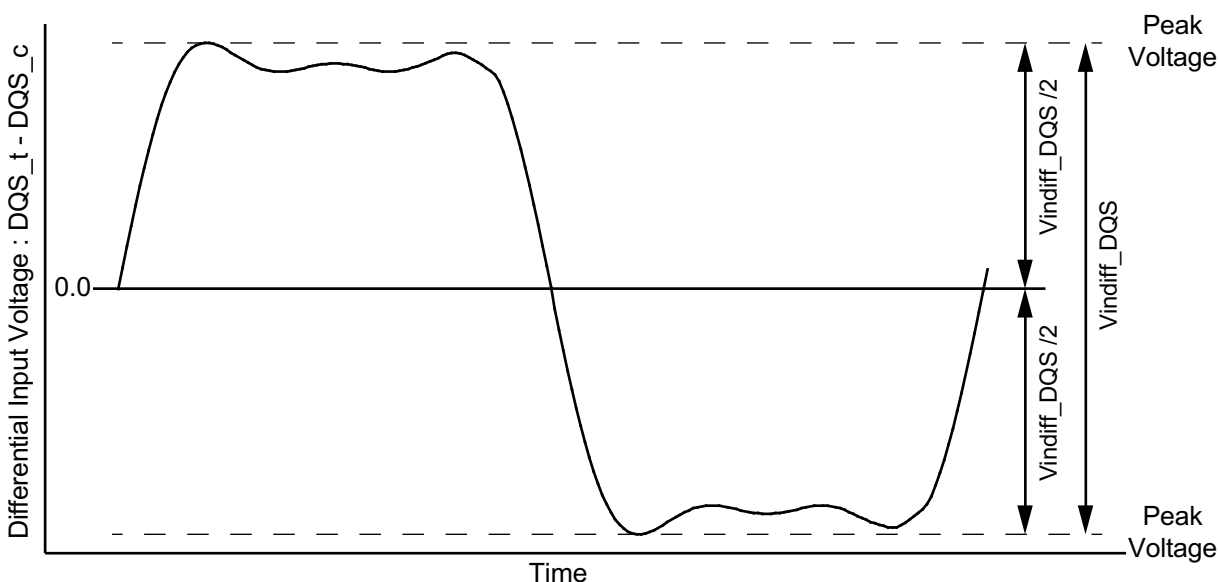

Figure 162 - DQS Differential Input Voltage

Table 104 - DQS differential input voltage

Parameter	Symbol	Data Rate						Unit	Notes
		1600/1867 ^a		2133/2400/3200		3733/4266			
		Min	Max	Min	Max	Min	Max		
DQS differential input	V_{indiff_DQS}	360	-	360	-	340	-	mV	1

Notes:

1. The peak voltage of Differential CK signals is calculated in a following equation.

$$V_{indiff_DQS} = (\text{Max Peak Voltage}) - (\text{Min Peak Voltage})$$

$$\text{Max Peak Voltage} = \text{Max}(f(t))$$

$$\text{Min Peak Voltage} = \text{Min}(f(t))$$

$$f(t) = VDQS_t - VDQS_c$$

a. The following requirements apply for DQ operating frequencies at or below 1333Gbps for all speed bins for the first column 1600/1867.

5.2.7. Peak voltage calculation method

The peak voltage of Differential DQS signals are calculated in a following equation.

$$\text{VIH.DIFF.Peak Voltage} = \text{Max}(f(t))$$

$$\text{VIL.DIFF.Peak Voltage} = \text{Min}(f(t))$$

$$f(t) = \text{VDQS}_t - \text{VDQS}_c$$

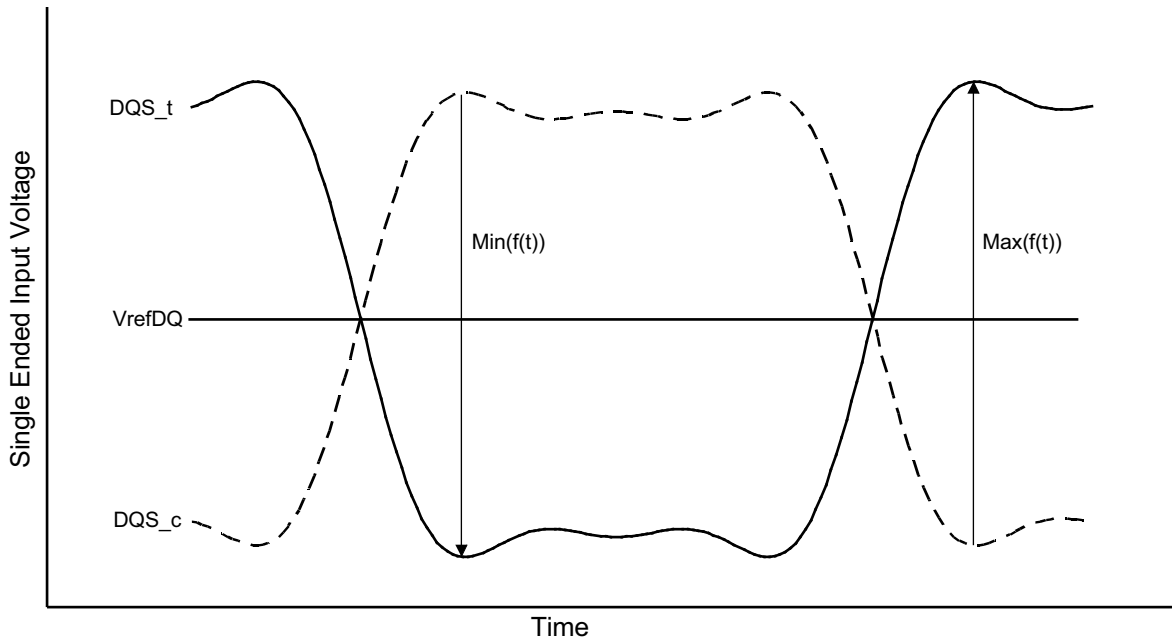

NOTES : 1. VrefDQ is LPDDR4 SDRAM internal setting value by Vref Training.

Figure 163 - Definition of differential DQS Peak Voltage

5.2.8. Single-Ended Input Voltage for DQS

The minimum input voltage need to satisfy both V_{inse_DQS} , $V_{inse_DQS_High/Low}$ specification at input receiver.

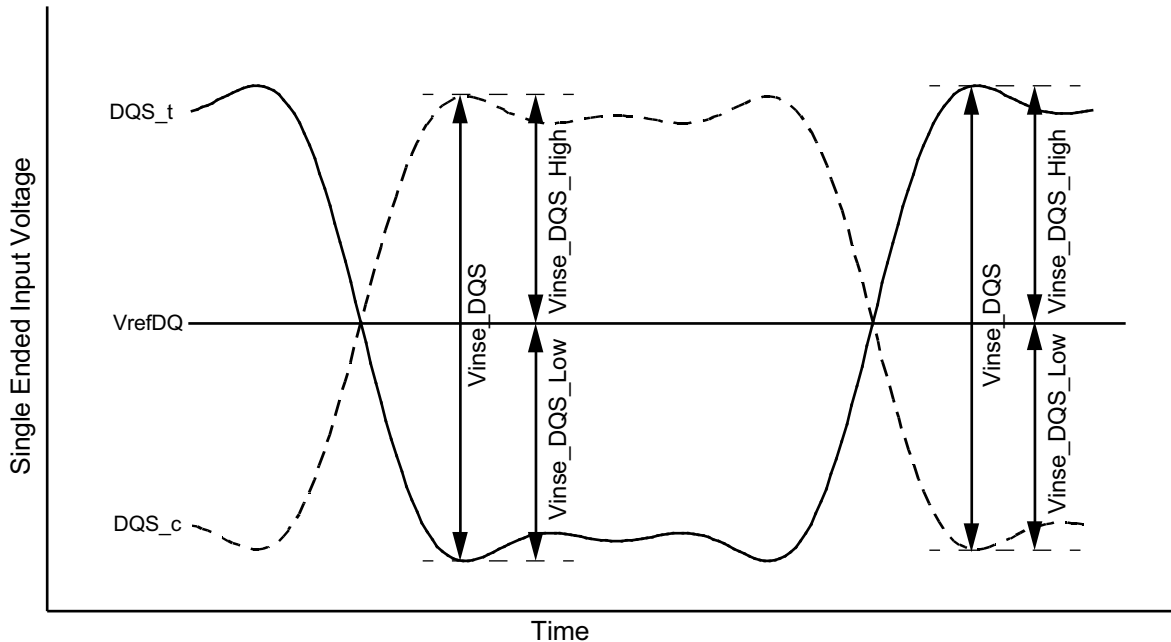

NOTES : 1. V_{refDQ} is LPDDR4 SDRAM internal setting value by Vref Training.

Figure 164 - DQS Single-Ended Input Voltage

Table 105 - DQS Single-Ended input voltage

Parameter	Symbol	Data Rate						Unit	Note
		1600/1867 ^a		2133/2400/3200		3733/4266			
		Min	Max	Min	Max	Min	Max		
DQS Single-Ended input voltage	V_{inse_DQS}	180	-	180	-	170	-	mV	
DQS Single-Ended input voltage High from V_{REFDQ}	$V_{inse_DQS_High}$	90	-	90	-	85	-	mV	
DQS Single-Ended input voltage Low from V_{REFDQ}	$V_{inse_DQS_Low}$	90	-	90	-	85	-	mV	

a. The following requirements apply for DQ operating frequencies at or below 1333Mbps for all speed bins for the first column 1600/1867.

5.2.9. Differential Input Slew Rate Definition for DQS

Input slew rate for differential signals (DQS_t, DQS_c) are defined and measured as shown in Figure below and Table below.

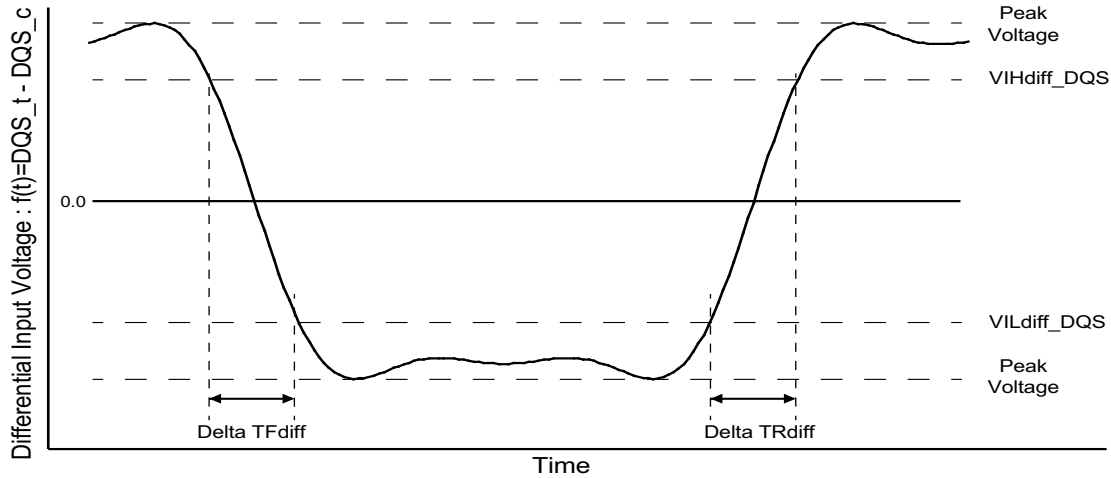

NOTES : 1. Differential signal rising edge from VILdiff_DQS to VIHdiff_DQS must be monotonic slope.
 2. Differential signal falling edge from VIHdiff_DQS to VILdiff_DQS must be monotonic slope.

Figure 165 - Differential Input Slew Rate Definition for DQS_t, DQS_c

Table 106 - Differential Input Slew Rate Definition for DQS_t, DQS_c

Description	From	To	Defined by
	Differential input slew rate for rising edge(DQS _t - DQS _c)	VILdiff_DQS	
Differential input slew rate for falling edge(DQS _t - DQS _c)	VIHdiff_DQS	VILdiff_DQS	$ VILdiff_DQS - VIHdiff_DQS / \Delta TFdiff$

Table 107 - Differential Input Level for DQS_t, DQS_c

Parameter	Symbol	Data Rate						Unit	Note
		1600/1867 ^a		2133/2400/3200		3733/4266			
		Min	Max	Min	Max	Min	Max		
Differential Input High	VIHdiff_DQS	140	-	140	-	120	-	mV	
Differential Input Low	VILdiff_DQS	-	-140	-	-140	-	-120	mV	

a. The following requirements apply for DQ operating frequencies at or below 1333Mbps for all speed bins for the first column 1600/1867.

Table 108 - Differential Input Slew Rate for DQS_t, DQS_c

Parameter	Symbol	Data Rate						Unit	Note
		1600/1867 ^a		2133/2400/3200		3733/4266			
		Min	Max	Min	Max	Min	Max		
Differential Input Slew Rate	SRI _{diff}	2	14	2	14	2	14	V/ns	

NOTE 1 The following requirements apply for DQ operating frequencies at or below 1333Mbps for all speed bins for the first column, 1600/1867.

5.2.10. Differential Input Cross Point Voltage

The cross point voltage of differential input signals (DQS_t, DQS_c) must meet the requirements in Table below. The differential input cross point voltage VIX is measured from the actual cross point of true and complement signals to the mid level that is V_{REFDQ} .

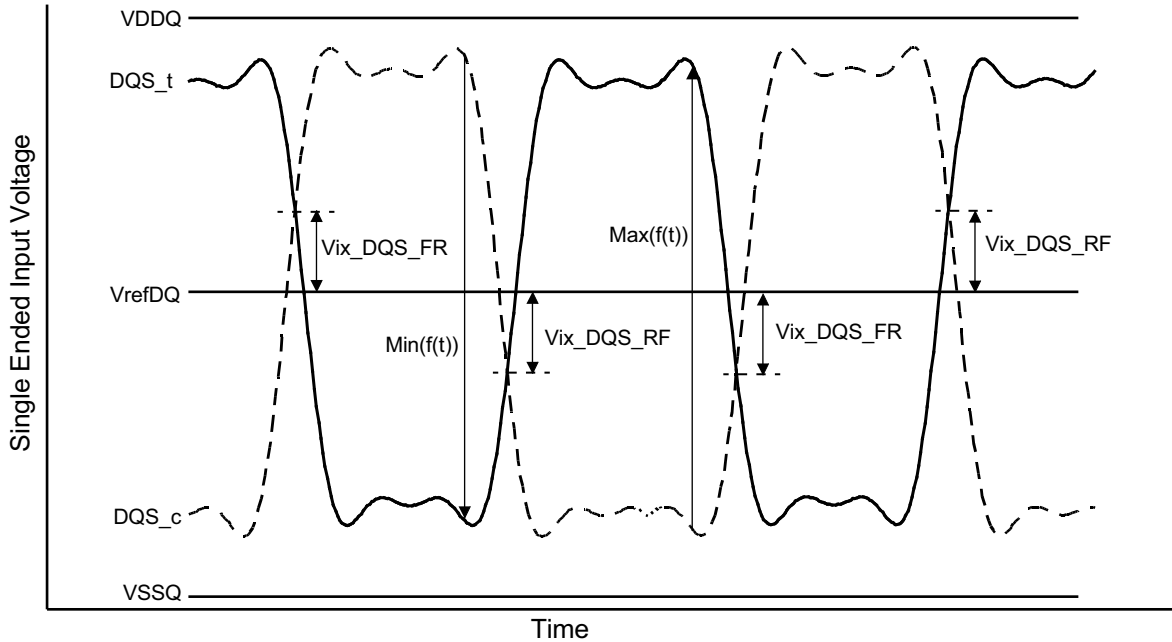

NOTES : 1. The base level of Vix_DQS_FR/RF is VrefDQ that is LPDDR4 SDRAM internal setting value by Vref Training.

Figure 166 - Vix Definition (DQS)

Table 109 - Cross point voltage for differential input signals (DQS)

Parameter	Symbol	Data Rate						Unit	Note
		1600/1867 ^a		2133/2400/3200		3733/4266			
		Min	Max	Min	Max	Min	Max		
DQS Differential input cross point voltage ratio	Vix_DQS_ratio	-	20	-	20	-	20	%	1,2
a. The following requirements apply for DQ operating frequencies at or below 1333Mbps for all speed bins for the first column 1600/1867.									

Note

1. Vix_CK_Ratio is defined by this equation: $Vix_CK_Ratio = Vix_CK_FR / |\text{Min}(f(t))|$

2. Vix_CK_Ratio is defined by this equation: $Vix_CK_Ratio = Vix_CK_RF / \text{Max}(f(t))$

a. The following requirements apply for DQ operating frequencies at or below 1333Gbps for all speed bins for the first column 1600/1867.

5.3. Input Level for ODT(ca) input

Table 110 - LPDDR4 Input level for ODT(ca)

Symbol	Min	Max	Unit	Notes
ODT Input high level	$0.75 \cdot VDD2$	$VDD2 + 0.2$	V	
ODT Input low level	-0.2	$0.25 \cdot VDD2$	V	

5.4. Single Ended Output Slew Rate

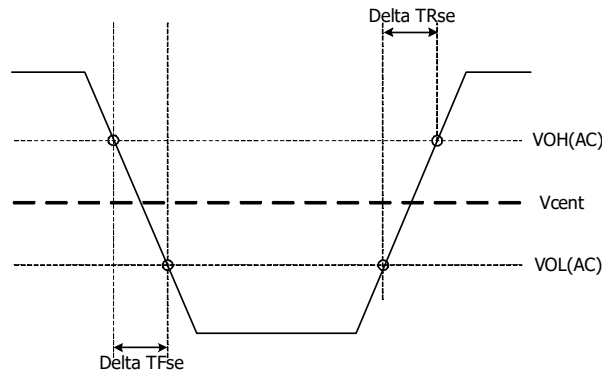

Figure 167 - Single Ended Output Slew Rate Definition

Table 111 - Output Slew Rate (Single-ended)

Parameter	Symbol	Value		Units
		Min (Note 1)	Max (Note 2)	
Single-ended Output Slew Rate ($VOH = VDDQ \cdot 0.5$)	SRQse	3.0	9.0	V/ns
Output slew-rate matching ratio (Rise to Fall)		0.8	1.2	

Description: SR: Slew Rate
 Q: Query Output (like in DQ, which stands for Data-in, Query-Output)
 se: Single-ended Signals

Notes

1. Measured with output reference load.
2. The ratio of pull-up to pull-down slew rate is specified for the same temperature and voltage, over the entire temperature and voltage range. For a given output, it represents the maximum difference between pull-up and pull-down drivers due to process variation.
3. The output slew rate for falling and rising edges is defined and measured between $VOL(AC) = 0.2 \cdot VOH(DC)$ and $VOH(AC) = 0.8 \cdot VOH(DC)$.
4. Slew rates are measured under average SSO conditions, with 50% of DQ signals per data byte switching.

5.5. Differential Output Slew Rate

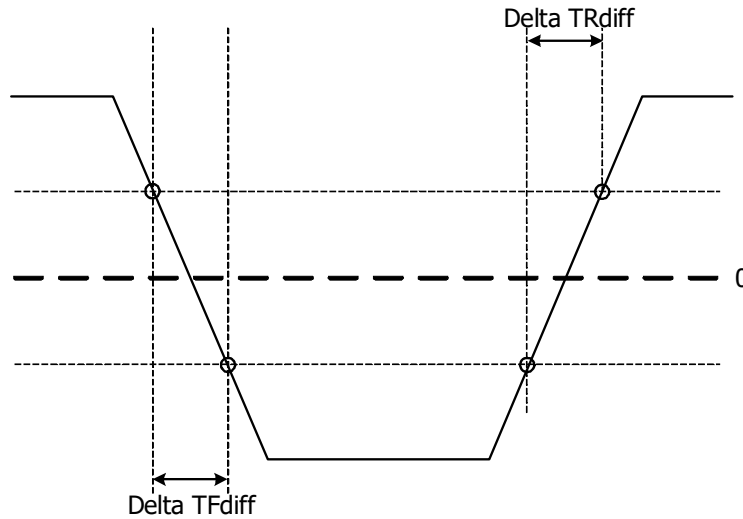

Figure 168 - Differential Output Slew Rate Definition

Table 112 - Differential Output Slew Rate

Parameter	Symbol	Value		Units
		Min (Note 1)	Max (Note 2)	
Differential Output Slew Rate (VOH = VDDQ*0.5)	SRQdiff	6	18	V/ns
Description: SR: Slew Rate Q: Query Output (like in DQ, which stands for Data-in, Query-Output) diff: Differential Signals				

Notes

1. Measured with output reference load.
2. The output slew rate for falling and rising edges is defined and measured between VOL(AC)= -0.8*VOH(DC) and VOH(AC)= 0.8*VOH(DC).
3. Slew rates are measured under average SSO conditions, with 50% of DQ signals per data byte switching.

5.6. Overshoot and Undershoot Specification for LVSTL

The levels are provided in Table below and Figure below.

Table 113 - AC Overshoot / Undershoot Specification

Parameter	Value	Units
Maximum peak amplitude allowed for overshoot area	0.3	V
Maximum peak amplitude allowed for undershoot area	0.3	V
Maximum overshoot area above VDD/VDDQ	0.1	V-ns
Maximum undershoot area below VSS/VSSQ	0.1	V-ns

Notes

1. VDD stands for VDD2 for CA[5:0], CK_t, CK_c, CS_n, CKE and ODT. VDD stands for VDDQ for DQ, DMI, DQS_t and DQS_c.
2. VSS stands for VSS for CA[5:0], CK_t, CK_c, CS_n, CKE and ODT. VSS stands for VSSQ for DQ, DMI, DQS_t and DQS_c.
3. Maximum peak amplitude values are referenced from actual VDD and VSS values.
4. Maximum area values are referenced from maximum operating VDD and VSS values.

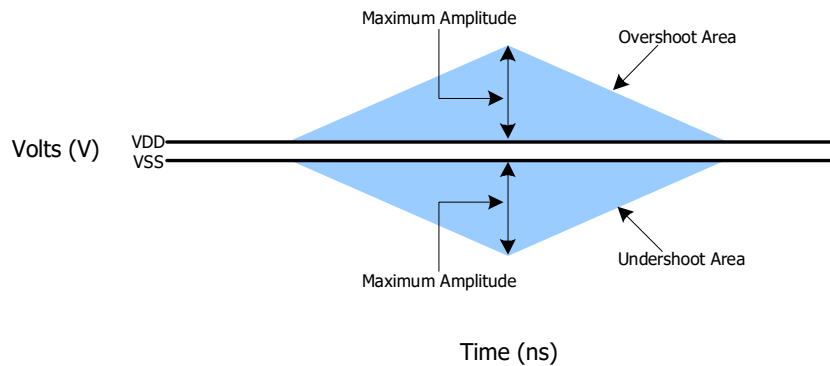
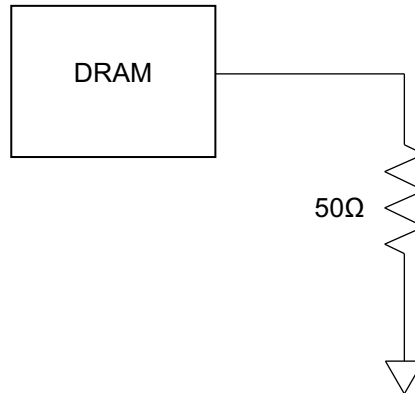

Figure 169 - AC Overshoot and Undershoot Definition

5.7. LVSTL Driver Output Timing Reference Load

These 'Timing Reference Loads' are not intended as a precise representation of any particular system environment or a depiction of the actual load presented by a production tester. System designers should use IBIS or other simulation tools to correlate the timing reference load to a system environment. Manufacturers correlate to their production test conditions, generally one or more coaxial transmission lines terminated at the tester electronics.



Note

1. All output timing parameter values are reported with respect to this reference load. This reference load is also used to report slew rate.

Figure 170 - Driver Output Reference Load for Timing and Slew Rate

5.8. LVSTL (Low Voltage Swing Terminated Logic) IO System

LVSTL I/O cell is comprised of pull-up, pull-down driver and a terminator. The basic cell is shown in figure below.

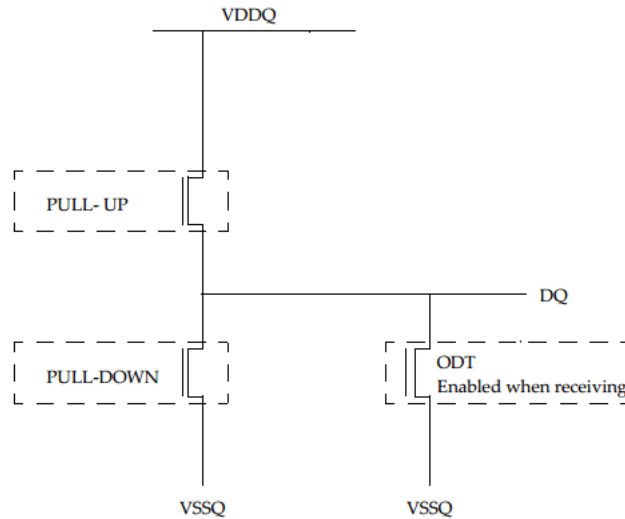

Figure 171 - LVSTL I/O Cell

To ensure that the target impedance is achieved the LVSTL I/O cell is designed to calibrated as below procedure.

1. First calibrate the pull-down device against a 240 Ω resistor to V_{DDQ} via the ZQ pin.

- Set Strength Control to minimum setting.
- Increase drive strength until comparator detects data bit is less than $V_{DDQ}/2$.
- NMOS pull-down device is calibrated to 240 Ω.

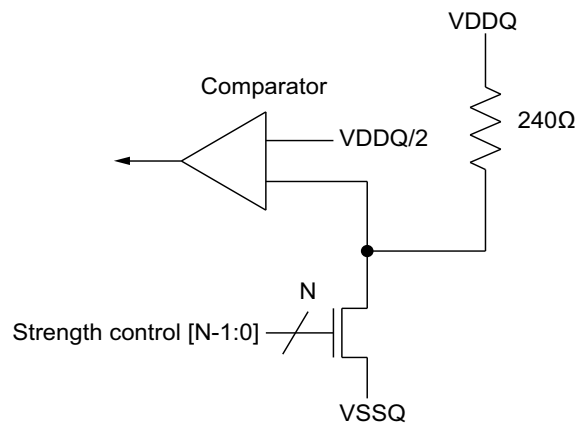

Figure 172 - Pull-down calibration

2. Then calibrate the pull-up device against the calibrated pull-down device.
 - Set VOH target and NMOS controller ODT replica via MRS (VOH can be automatically controlled by ODT MRS).
 - Set Strength Control to minimum setting.
 - Increase drive strength until comparator detects data bit is greater than VOH target.
 - NMOS pull-up device is now calibrated to VOH target.

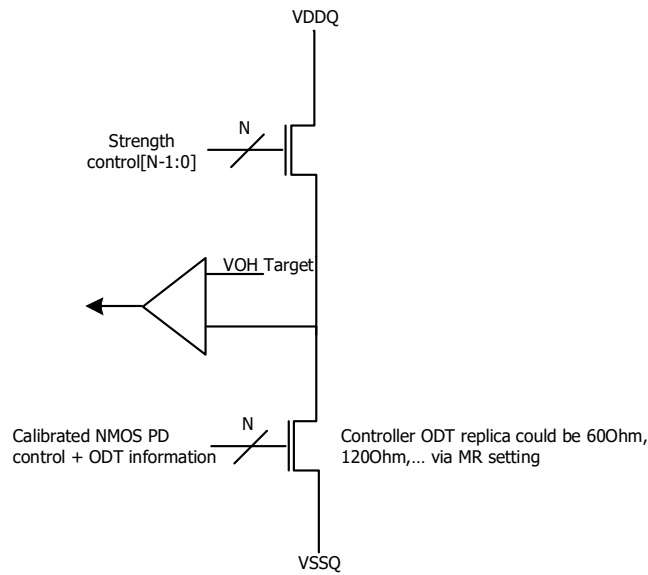

Figure 173 - Pull-up calibration

6. Input/Output Capacitance

Table 114 - Input/Output Capacitance

Parameter	Symbol	Min/Max	4266-533	Unit	Note
Input capacitance, CK_t and CK_c	CCK	Min	0.5	pF	1,2
		Max	0.9		
Input capacitance delta, CK_t and CK_c	CDCK	Min	0.0	pF	1,2,3
		Max	0.09		
Input capacitance, all other input-only pins	CI	Min	0.5	pF	1,2,4
		Max	0.9		
Input capacitance delta, all other input-only pins	CDI	Min	-0.1	pF	1,2,5
		Max	0.1		
Input/output capacitance, DQ, DMI, DQS_t, DQS_c	CIO	Min	0.7	pF	1,2,6
		Max	1.3		
Input/output capacitance delta, DQS_t and DQS_c	CDDQS	Min	0.0	pF	1,2,7
		Max	0.1		
Input/output capacitance delta, DQ and DM	CDIO	Min	-0.1	pF	1,2,8
		Max	0.1		
Input/Output Capacitance ZQ	CZQ	Min	0.0	pF	1,2
		Max	5.0		

Notes

1. This parameter applies to die device only (does not include package capacitance).
2. This parameter is not subject to production test. It is verified by design and characterization. The capacitance is measured according to JEP147 (Procedure for measuring input capacitance using a vector network analyzer (VNA) with VDD1, VDD2, VDDQ, VSS, VSSQ applied and all other pins floating).
3. Absolute value of CCK_t . CCK_c.
4. CI applies to CS_n, CKE, CA0~CA5.
5. $CDI = CI \cdot 0.5 \cdot (CCK_t + CCK_c)$
6. DMI loading matches DQ and DQS.
7. Absolute value of CDQS_t and CDQS_c.
8. $CDIO = CIO \cdot 0.5 \cdot (CDQS_t + CDQS_c)$ in byte-lane.

7. IDD Specification Parameters and Test Conditions

7.1. IDD Measurement Conditions

The following definitions are used within the IDD measurement tables unless stated otherwise:

LOW: $V_{IN} \leq V_{IL(DC) MAX}$

HIGH: $V_{IN} \geq V_{IH(DC) MIN}$

STABLE: Inputs are stable at a HIGH or LOW level

SWITCHING: See following tables for switching definition of signals.

Table 115 - Definition of switching for CA input signals

Switching for CA								
CK_t edge	R1	R2	R3	R4	R5	R6	R7	R8
CKE	HIGH	HIGH	HIGH	HIGH	HIGH	HIGH	HIGH	HIGH
CS	LOW	LOW	LOW	LOW	LOW	LOW	LOW	LOW
CA0	HIGH	LOW	LOW	LOW	LOW	HIGH	HIGH	HIGH
CA1	HIGH	HIGH	HIGH	LOW	LOW	LOW	LOW	HIGH
CA2	HIGH	LOW	LOW	LOW	LOW	HIGH	HIGH	HIGH
CA3	HIGH	HIGH	HIGH	LOW	LOW	LOW	LOW	HIGH
CA4	HIGH	LOW	LOW	LOW	LOW	HIGH	HIGH	HIGH
CA5	HIGH	HIGH	HIGH	LOW	LOW	LOW	LOW	HIGH

Notes

1. CS must always be driven LOW.

2. 50% of CA bus is changing between HIGH and LOW once per clock for the CA bus.

3. The above pattern is used continuously during IDD measurement for IDD values that require switching on the CA bus.

Table 116 - CA pattern for IDD4R for BL=16

Clock Cycle Number	CKE	CS	Command	CA0	CA1	CA2	CA3	CA4	CA5
N	HIGH	HIGH	Read-1	L	H	L	L	L	L
N+1	HIGH	LOW		L	H	L	L	L	L
N+2	HIGH	HIGH	CAS-2	L	H	L	L	H	L
N+3	HIGH	LOW		L	L	L	L	L	L
N+4	HIGH	LOW	DES	L	L	L	L	L	L
N+5	HIGH	LOW	DES	L	L	L	L	L	L
N+6	HIGH	LOW	DES	L	L	L	L	L	L
N+7	HIGH	LOW	DES	L	L	L	L	L	L
N+8	HIGH	HIGH	Read-1	L	H	L	L	L	L
N+9	HIGH	LOW		L	H	L	L	H	L
N+10	HIGH	HIGH	CAS-2	L	H	L	L	H	H
N+11	HIGH	LOW		H	H	H	H	H	H
N+12	HIGH	LOW	DES	L	L	L	L	L	L
N+13	HIGH	LOW	DES	L	L	L	L	L	L
N+14	HIGH	LOW	DES	L	L	L	L	L	L
N+15	HIGH	LOW	DES	L	L	L	L	L	L

Notes

1. BA[2:0] = 010, C[9:4] = 000000 or 111111, Burst Order C[3:2] = 00 or 11 (Same as LPDDR3 IDD4R Spec)

2. Difference from LPDDR3 Spec : CA pins are kept low with DES CMD to reduce ODT current.

Table 117 - CA pattern for IDD4W for BL=16

Clock Cycle Number	CKE	CS	Command	CA0	CA1	CA2	CA3	CA4	CA5
N	HIGH	HIGH	Write-1	L	L	H	L	L	L
N+1	HIGH	LOW		L	H	L	L	L	L
N+2	HIGH	HIGH	CAS-2	L	H	L	L	H	L
N+3	HIGH	LOW		L	L	L	L	L	L
N+4	HIGH	LOW	Deselect	L	L	L	L	L	L
N+5	HIGH	LOW	Deselect	L	L	L	L	L	L
N+6	HIGH	LOW	Deselect	L	L	L	L	L	L
N+7	HIGH	LOW	Deselect	L	L	L	L	L	L
N+8	HIGH	HIGH	Write-1	L	L	H	L	L	L
N+9	HIGH	LOW		L	H	L	L	H	L
N+10	HIGH	HIGH	CAS-2	L	H	L	L	H	H
N+11	HIGH	LOW		L	L	H	H	H	H
N+12	HIGH	LOW	Deselect	L	L	L	L	L	L
N+13	HIGH	LOW	Deselect	L	L	L	L	L	L
N+14	HIGH	LOW	Deselect	L	L	L	L	L	L
N+15	HIGH	LOW	Deselect	L	L	L	L	L	L

Notes

1. BA[2:0] = 010, C[9:4] = 000000 or 111111 (Same as LPDDR3 IDD4W Spec.)
2. Difference from LPDDR3 Spec:
 - 1-No burst ordering
 - 2-CA pins are kept low with DES CMD to reduce ODT current.

Table 118 - Data Pattern for IDD4W (DBI off) for BL=16

DBI OFF case										No. of 1's
	DQ[7]	DQ[6]	DQ[5]	DQ[4]	DQ[3]	DQ[2]	DQ[1]	DQ[0]	DBI	
BL0	1	1	1	1	1	1	1	1	0	8
BL1	1	1	1	1	0	0	0	0	0	4
BL2	0	0	0	0	0	0	0	0	0	0
BL3	0	0	0	0	1	1	1	1	0	4
BL4	0	0	0	0	0	0	1	1	0	2
BL5	0	0	0	0	1	1	1	1	0	4
BL6	1	1	1	1	1	1	0	0	0	6
BL7	1	1	1	1	0	0	0	0	0	4
BL8	1	1	1	1	1	1	1	1	0	8
BL9	1	1	1	1	0	0	0	0	0	4
BL10	0	0	0	0	0	0	0	0	0	0
BL11	0	0	0	0	1	1	1	1	0	4
BL12	0	0	0	0	0	0	1	1	0	2
BL13	0	0	0	0	1	1	1	1	0	4
BL14	1	1	1	1	1	1	0	0	0	6
BL15	1	1	1	1	0	0	0	0	0	4
BL16	1	1	1	1	1	1	0	0	0	6
BL17	1	1	1	1	0	0	0	0	0	4
BL18	0	0	0	0	0	0	1	1	0	2
BL19	0	0	0	0	1	1	1	1	0	4
BL20	0	0	0	0	0	0	0	0	0	0
BL21	0	0	0	0	1	1	1	1	0	4
BL22	1	1	1	1	1	1	1	1	0	8
BL23	1	1	1	1	0	0	0	0	0	4
BL24	0	0	0	0	0	0	1	1	0	2
BL25	0	0	0	0	1	1	1	1	0	4
BL26	1	1	1	1	1	1	0	0	0	6
BL27	1	1	1	1	0	0	0	0	0	4
BL28	1	1	1	1	1	1	1	1	0	8
BL29	1	1	1	1	0	0	0	0	0	4
BL30	0	0	0	0	0	0	0	0	0	0
BL31	0	0	0	0	1	1	1	1	0	4
No. of 1's	16	16	16	16	16	16	16	16		

Notes

1. Simplified pattern compared with last showing.
2. Same data pattern was applied to DQ[4], DQ[5], DQ[6], DQ[7] for reducing complexity for IDD4W/R pattern programming.

Table 119 - Data Pattern for IDD4R (DBI off) for BL=16

DBI OFF case										No. of 1's
	DQ[7]	DQ[6]	DQ[5]	DQ[4]	DQ[3]	DQ[2]	DQ[1]	DQ[0]	DBI	
BL0	1	1	1	1	1	1	1	1	0	8
BL1	1	1	1	1	0	0	0	0	0	4
BL2	0	0	0	0	0	0	0	0	0	0
BL3	0	0	0	0	1	1	1	1	0	4
BL4	0	0	0	0	0	0	1	1	0	2
BL5	0	0	0	0	1	1	1	1	0	4
BL6	1	1	1	1	1	1	0	0	0	6
BL7	1	1	1	1	0	0	0	0	0	4
BL8	1	1	1	1	1	1	1	1	0	8
BL9	1	1	1	1	0	0	0	0	0	4
BL10	0	0	0	0	0	0	0	0	0	0
BL11	0	0	0	0	1	1	1	1	0	4
BL12	0	0	0	0	0	0	1	1	0	2
BL13	0	0	0	0	1	1	1	1	0	4
BL14	1	1	1	1	1	1	0	0	0	6
BL15	1	1	1	1	0	0	0	0	0	4
BL16	1	1	1	1	1	1	1	1	0	8
BL17	1	1	1	1	0	0	0	0	0	4
BL18	0	0	0	0	0	0	0	0	0	0
BL19	0	0	0	0	1	1	1	1	0	4
BL20	1	1	1	1	1	1	0	0	0	6
BL21	1	1	1	1	0	0	0	0	0	4
BL22	0	0	0	0	0	0	1	1	0	2
BL23	0	0	0	0	1	1	1	1	0	4
BL24	0	0	0	0	0	0	0	0	0	0
BL25	0	0	0	0	1	1	1	1	0	4
BL26	1	1	1	1	1	1	1	1	0	8
BL27	1	1	1	1	0	0	0	0	0	4
BL28	0	0	0	0	0	0	1	1	0	2
BL29	0	0	0	0	1	1	1	1	0	4
BL30	1	1	1	1	1	1	0	0	0	6
BL31	1	1	1	1	0	0	0	0	0	4
No. of 1's	16	16	16	16	16	16	16	16		

Notes

1. Same data pattern was applied to DQ[4], DQ[5], DQ[6], DQ[7] for reducing complexity for IDD4W/R pattern programming.

Table 120 - Data Pattern for IDD4W (DBI on) for BL=16

DBI ON case										No. of 1's
	DQ[7]	DQ[6]	DQ[5]	DQ[4]	DQ[3]	DQ[2]	DQ[1]	DQ[0]	DBI	
BL0	0	0	0	0	0	0	0	0	1	1
BL1	1	1	1	1	0	0	0	0	0	4
BL2	0	0	0	0	0	0	0	0	0	0
BL3	0	0	0	0	1	1	1	1	0	4
BL4	0	0	0	0	0	0	1	1	0	2
BL5	0	0	0	0	1	1	1	1	0	4
BL6	0	0	0	0	0	0	1	1	1	3
BL7	1	1	1	1	0	0	0	0	0	4
BL8	0	0	0	0	0	0	0	0	1	1
BL9	1	1	1	1	0	0	0	0	0	4
BL10	0	0	0	0	0	0	0	0	0	0
BL11	0	0	0	0	1	1	1	1	0	4
BL12	0	0	0	0	0	0	1	1	0	2
BL13	0	0	0	0	1	1	1	1	0	4
BL14	0	0	0	0	0	0	1	1	1	3
BL15	1	1	1	1	0	0	0	0	0	4
BL16	0	0	0	0	0	0	1	1	1	3
BL17	1	1	1	1	0	0	0	0	0	4
BL18	0	0	0	0	0	0	1	1	0	2
BL19	0	0	0	0	1	1	1	1	0	4
BL20	0	0	0	0	0	0	0	0	0	0
BL21	0	0	0	0	1	1	1	1	0	4
BL22	0	0	0	0	0	0	0	0	1	1
BL23	1	1	1	1	0	0	0	0	0	4
BL24	0	0	0	0	0	0	1	1	0	2
BL25	0	0	0	0	1	1	1	1	0	4
BL26	0	0	0	0	0	0	1	1	1	3
BL27	1	1	1	1	0	0	0	0	0	4
BL28	0	0	0	0	0	0	0	0	1	1
BL29	1	1	1	1	0	0	0	0	0	4
BL30	0	0	0	0	0	0	0	0	0	0
BL31	0	0	0	0	1	1	1	1	0	4
No. of 1's	8	8	8	8	8	8	16	16	8	

Notes:

1. Green colored cells are DBI enabled burst.

Table 121 - Data Pattern for IDD4R (DBI on) for BL=16

DBI ON case										No. of 1's
	DQ[7]	DQ[6]	DQ[5]	DQ[4]	DQ[3]	DQ[2]	DQ[1]	DQ[0]	DBI	
BL0	0	0	0	0	0	0	0	0	1	1
BL1	1	1	1	1	0	0	0	0	0	4
BL2	0	0	0	0	0	0	0	0	0	0
BL3	0	0	0	0	1	1	1	1	0	4
BL4	0	0	0	0	0	0	1	1	0	2
BL5	0	0	0	0	1	1	1	1	0	4
BL6	0	0	0	0	0	0	1	1	1	3
BL7	1	1	1	1	0	0	0	0	0	4
BL8	0	0	0	0	0	0	0	0	1	1
BL9	1	1	1	1	0	0	0	0	0	4
BL10	0	0	0	0	0	0	0	0	0	0
BL11	0	0	0	0	1	1	1	1	0	4
BL12	0	0	0	0	0	0	1	1	0	2
BL13	0	0	0	0	1	1	1	1	0	4
BL14	0	0	0	0	0	0	1	1	1	3
BL15	1	1	1	1	0	0	0	0	0	4
BL16	0	0	0	0	0	0	0	0	1	1
BL17	1	1	1	1	0	0	0	0	0	4
BL18	0	0	0	0	0	0	0	0	0	0
BL19	0	0	0	0	1	1	1	1	0	4
BL20	0	0	0	0	0	0	1	1	1	3
BL21	1	1	1	1	0	0	0	0	0	4
BL22	0	0	0	0	0	0	1	1	0	2
BL23	0	0	0	0	1	1	1	1	0	4
BL24	0	0	0	0	0	0	0	0	0	0
BL25	0	0	0	0	1	1	1	1	0	4
BL26	0	0	0	0	0	0	0	0	1	1
BL27	1	1	1	1	0	0	0	0	0	4
BL28	0	0	0	0	0	0	1	1	0	2
BL29	0	0	0	0	1	1	1	1	0	4
BL30	0	0	0	0	0	0	1	1	1	3
BL31	1	1	1	1	0	0	0	0	0	4
No. of 1's	8	8	8	8	8	8	16	16	8	

Notes:

1. Green colored cells are DBI enabled burst.

Table 122 - CA pattern for IDD4R for BL=32

Clock Cycle Number	CKE	CS	Command	CA0	CA1	CA2	CA3	CA4	CA5
N	HIGH	HIGH	Read-1	L	H	L	L	L	L
N+1	HIGH	LOW		L	H	L	L	L	L
N+2	HIGH	HIGH	CAS-2	L	H	L	L	H	L
N+3	HIGH	LOW		L	L	L	L	L	L
N+4	HIGH	LOW	DES	L	L	L	L	L	L
N+5	HIGH	LOW	DES	L	L	L	L	L	L
N+6	HIGH	LOW	DES	L	L	L	L	L	L
N+7	HIGH	LOW	DES	L	L	L	L	L	L
N+8	HIGH	LOW	DES	L	L	L	L	L	L
N+9	HIGH	LOW	DES	L	L	L	L	L	L
N+10	HIGH	LOW	DES	L	L	L	L	L	L
N+11	HIGH	LOW	DES	L	L	L	L	L	L
N+12	HIGH	LOW	DES	L	L	L	L	L	L
N+13	HIGH	LOW	DES	L	L	L	L	L	L
N+14	HIGH	LOW	DES	L	L	L	L	L	L
N+15	HIGH	LOW	DES	L	L	L	L	L	L
N+16	HIGH	HIGH	Read-1	L	H	L	L	L	L
N+17	HIGH	LOW		L	H	L	L	H	L
N+18	HIGH	HIGH	CAS-2	L	H	L	L	H	H
N+19	HIGH	LOW		H	H	L	H	H	H
N+20	HIGH	LOW	DES	L	L	L	L	L	L
N+21	HIGH	LOW	DES	L	L	L	L	L	L
N+22	HIGH	LOW	DES	L	L	L	L	L	L
N+23	HIGH	LOW	DES	L	L	L	L	L	L
N+24	HIGH	LOW	DES	L	L	L	L	L	L
N+25	HIGH	LOW	DES	L	L	L	L	L	L
N+26	HIGH	LOW	DES	L	L	L	L	L	L
N+27	HIGH	LOW	DES	L	L	L	L	L	L
N+28	HIGH	LOW	DES	L	L	L	L	L	L
N+29	HIGH	LOW	DES	L	L	L	L	L	L
N+30	HIGH	LOW	DES	L	L	L	L	L	L
N+31	HIGH	LOW	DES	L	L	L	L	L	L
N	HIGH	HIGH	Read-1	L	H	L	L	L	L

Notes:

1. BA[2:0] = 010, C[9:5] = 00000 or 11111, Burst Order C[4:2] = 000 or 111

Table 123 - CA pattern for IDD4W for BL=32

Clock Cycle Number	CKE	CS	Command	CA0	CA1	CA2	CA3	CA4	CA5
N	HIGH	HIGH	Write-1	L	L	H	L	L	L
N+1	HIGH	LOW		L	H	L	L	L	L
N+2	HIGH	HIGH	CAS-2	L	H	L	L	H	L
N+3	HIGH	LOW		L	L	L	L	L	L
N+4	HIGH	LOW	DES	L	L	L	L	L	L
N+5	HIGH	LOW	DES	L	L	L	L	L	L
N+6	HIGH	LOW	DES	L	L	L	L	L	L
N+7	HIGH	LOW	DES	L	L	L	L	L	L
N+8	HIGH	LOW	DES	L	L	L	L	L	L
N+9	HIGH	LOW	DES	L	L	L	L	L	L
N+10	HIGH	LOW	DES	L	L	L	L	L	L
N+11	HIGH	LOW	DES	L	L	L	L	L	L
N+12	HIGH	LOW	DES	L	L	L	L	L	L
N+13	HIGH	LOW	DES	L	L	L	L	L	L
N+14	HIGH	LOW	DES	L	L	L	L	L	L
N+15	HIGH	LOW	DES	L	L	L	L	L	L
N+16	HIGH	HIGH	Write-1	L	L	H	L	L	L
N+17	HIGH	LOW		L	H	L	L	H	L
N+18	HIGH	HIGH	CAS-2	L	H	L	L	H	H
N+19	HIGH	LOW		L	L	L	H	H	H
N+20	HIGH	LOW	DES	L	L	L	L	L	L
N+21	HIGH	LOW	DES	L	L	L	L	L	L
N+22	HIGH	LOW	DES	L	L	L	L	L	L
N+23	HIGH	LOW	DES	L	L	L	L	L	L
N+24	HIGH	LOW	DES	L	L	L	L	L	L
N+25	HIGH	LOW	DES	L	L	L	L	L	L
N+26	HIGH	LOW	DES	L	L	L	L	L	L
N+27	HIGH	LOW	DES	L	L	L	L	L	L
N+28	HIGH	LOW	DES	L	L	L	L	L	L
N+29	HIGH	LOW	DES	L	L	L	L	L	L
N+30	HIGH	LOW	DES	L	L	L	L	L	L
N+31	HIGH	LOW	DES	L	L	L	L	L	L
N	HIGH	HIGH	Write-1	L	L	H	L	L	L

Notes:

1. BA[2:0] = 010, C[9:5] = 00000 or 11111

Table 124 - Data Pattern for IDD4W (DBI off) for BL=32

	DBI OFF case									No. of 1's
	DQ[7]	DQ[6]	DQ[5]	DQ[4]	DQ[3]	DQ[2]	DQ[1]	DQ[0]	DBI	
BL0	1	1	1	1	1	1	1	1	0	8
BL1	1	1	1	1	0	0	0	0	0	4
BL2	0	0	0	0	0	0	0	0	0	0
BL3	0	0	0	0	1	1	1	1	0	4
BL4	0	0	0	0	0	0	1	1	0	2
BL5	0	0	0	0	1	1	1	1	0	4
BL6	1	1	1	1	1	1	0	0	0	6
BL7	1	1	1	1	0	0	0	0	0	4
BL8	1	1	1	1	1	1	1	1	0	8
BL9	1	1	1	1	0	0	0	0	0	4
BL10	0	0	0	0	0	0	0	0	0	0
BL11	0	0	0	0	1	1	1	1	0	4
BL12	0	0	0	0	0	0	1	1	0	2
BL13	0	0	0	0	1	1	1	1	0	4
BL14	1	1	1	1	1	1	0	0	0	6
BL15	1	1	1	1	0	0	0	0	0	4
BL16	1	1	1	1	1	1	0	0	0	6
BL17	1	1	1	1	0	0	0	0	0	4
BL18	0	0	0	0	0	0	1	1	0	2
BL19	0	0	0	0	1	1	1	1	0	4
BL20	0	0	0	0	0	0	0	0	0	0
BL21	0	0	0	0	1	1	1	1	0	4
BL22	1	1	1	1	1	1	1	1	0	8
BL23	1	1	1	1	0	0	0	0	0	4
BL24	0	0	0	0	0	0	1	1	0	2
BL25	0	0	0	0	1	1	1	1	0	4
BL26	1	1	1	1	1	1	0	0	0	6
BL27	1	1	1	1	0	0	0	0	0	4
BL28	1	1	1	1	1	1	1	1	0	8
BL29	1	1	1	1	0	0	0	0	0	4
BL30	0	0	0	0	0	0	0	0	0	0
BL31	0	0	0	0	1	1	1	1	0	4
BL32	1	1	1	1	1	1	1	1	0	8
BL33	1	1	1	1	0	0	0	0	0	4
BL34	0	0	0	0	0	0	0	0	0	0
BL35	0	0	0	0	1	1	1	1	0	4
BL36	0	0	0	0	0	0	1	1	0	2
BL37	0	0	0	0	1	1	1	1	0	4
BL38	1	1	1	1	1	1	0	0	0	6
BL39	1	1	1	1	0	0	0	0	0	4
BL40	1	1	1	1	1	1	1	1	0	8
BL41	1	1	1	1	0	0	0	0	0	4
BL42	0	0	0	0	0	0	0	0	0	0
BL43	0	0	0	0	1	1	1	1	0	4
BL44	0	0	0	0	0	0	1	1	0	2
BL45	0	0	0	0	1	1	1	1	0	4

DBI OFF case										No. of 1's
	DQ[7]	DQ[6]	DQ[5]	DQ[4]	DQ[3]	DQ[2]	DQ[1]	DQ[0]	DBI	
BL46	1	1	1	1	1	1	0	0	0	6
BL47	1	1	1	1	0	0	0	0	0	4
BL48	1	1	1	1	1	1	0	0	0	6
BL49	1	1	1	1	0	0	0	0	0	4
BL50	0	0	0	0	0	0	1	1	0	2
BL51	0	0	0	0	1	1	1	1	0	4
BL52	0	0	0	0	0	0	0	0	0	0
BL53	0	0	0	0	1	1	1	1	0	4
BL54	1	1	1	1	1	1	1	1	0	8
BL55	1	1	1	1	0	0	0	0	0	4
BL56	0	0	0	0	0	0	1	1	0	2
BL57	0	0	0	0	1	1	1	1	0	4
BL58	1	1	1	1	1	1	0	0	0	6
BL59	1	1	1	1	0	0	0	0	0	4
BL60	1	1	1	1	1	1	1	1	0	8
BL61	1	1	1	1	0	0	0	0	0	4
BL62	0	0	0	0	0	0	0	0	0	0
BL63	0	0	0	0	1	1	1	1	0	4
No. of 1's	32	32	32	32	32	32	32	32		

Notes

1. Simplified pattern compared with last showing. Same data pattern was applied to DQ[4], DQ[5], DQ[6], DQ[7] for reducing complexity for IDD4W/R pattern programming.

Table 125 - Data Pattern for IDD4R (DBI off) for BL=32

	DBI OFF case									No. of 1's
	DQ[7]	DQ[6]	DQ[5]	DQ[4]	DQ[3]	DQ[2]	DQ[1]	DQ[0]	DBI	
BL0	1	1	1	1	1	1	1	1	0	8
BL1	1	1	1	1	0	0	0	0	0	4
BL2	0	0	0	0	0	0	0	0	0	0
BL3	0	0	0	0	1	1	1	1	0	4
BL4	0	0	0	0	0	0	1	1	0	2
BL5	0	0	0	0	1	1	1	1	0	4
BL6	1	1	1	1	1	1	0	0	0	6
BL7	1	1	1	1	0	0	0	0	0	4
BL8	1	1	1	1	1	1	1	1	0	8
BL9	1	1	1	1	0	0	0	0	0	4
BL10	0	0	0	0	0	0	0	0	0	0
BL11	0	0	0	0	1	1	1	1	0	4
BL12	0	0	0	0	0	0	1	1	0	2
BL13	0	0	0	0	1	1	1	1	0	4
BL14	1	1	1	1	1	1	0	0	0	6
BL15	1	1	1	1	0	0	0	0	0	4
BL16	1	1	1	1	1	1	1	1	0	8
BL17	1	1	1	1	0	0	0	0	0	4
BL18	0	0	0	0	0	0	0	0	0	0
BL19	0	0	0	0	1	1	1	1	0	4
BL20	1	1	1	1	1	1	0	0	0	6
BL21	1	1	1	1	0	0	0	0	0	4
BL22	0	0	0	0	0	0	1	1	0	2
BL23	0	0	0	0	1	1	1	1	0	4
BL24	0	0	0	0	0	0	0	0	0	0
BL25	0	0	0	0	1	1	1	1	0	4
BL26	1	1	1	1	1	1	1	1	0	8
BL27	1	1	1	1	0	0	0	0	0	4
BL28	0	0	0	0	0	0	1	1	0	2
BL29	0	0	0	0	1	1	1	1	0	4
BL30	1	1	1	1	1	1	0	0	0	6
BL31	1	1	1	1	0	0	0	0	0	4
BL32	1	1	1	1	1	1	1	1	0	8
BL33	1	1	1	1	0	0	0	0	0	4
BL34	0	0	0	0	0	0	0	0	0	0
BL35	0	0	0	0	1	1	1	1	0	4
BL36	0	0	0	0	0	0	1	1	0	2
BL37	0	0	0	0	1	1	1	1	0	4
BL38	1	1	1	1	1	1	0	0	0	6
BL39	1	1	1	1	0	0	0	0	0	4
BL40	1	1	1	1	1	1	1	1	0	8
BL41	1	1	1	1	0	0	0	0	0	4
BL42	0	0	0	0	0	0	0	0	0	0
BL43	0	0	0	0	1	1	1	1	0	4
BL44	0	0	0	0	0	0	1	1	0	2
BL45	0	0	0	0	1	1	1	1	0	4

DBI OFF case										No. of 1's
	DQ[7]	DQ[6]	DQ[5]	DQ[4]	DQ[3]	DQ[2]	DQ[1]	DQ[0]	DBI	
BL46	1	1	1	1	1	1	0	0	0	6
BL47	1	1	1	1	0	0	0	0	0	4
BL48	1	1	1	1	1	1	1	1	0	8
BL49	1	1	1	1	0	0	0	0	0	4
BL50	0	0	0	0	0	0	0	0	0	0
BL51	0	0	0	0	1	1	1	1	0	4
BL52	1	1	1	1	1	1	0	0	0	6
BL53	1	1	1	1	0	0	0	0	0	4
BL54	0	0	0	0	0	0	1	1	0	2
BL55	0	0	0	0	1	1	1	1	0	4
BL56	0	0	0	0	0	0	0	0	0	0
BL57	0	0	0	0	1	1	1	1	0	4
BL58	1	1	1	1	1	1	1	1	0	8
BL59	1	1	1	1	0	0	0	0	0	4
BL60	0	0	0	0	0	0	1	1	0	2
BL61	0	0	0	0	1	1	1	1	0	4
BL62	1	1	1	1	1	1	0	0	0	6
BL63	1	1	1	1	0	0	0	0	0	4
No. of 1's	32	32	32	32	32	32	32	32		

Notes

1. Same data pattern was applied to DQ[4], DQ[5], DQ[6], DQ[7] for reducing complexity for IDD4W/R pattern programming.

Table 126 - Data Pattern for IDD4W (DBI on) for BL=32

	DBI ON case									No. of 1's
	DQ[7]	DQ[6]	DQ[5]	DQ[4]	DQ[3]	DQ[2]	DQ[1]	DQ[0]	DBI	
BL0	0	0	0	0	0	0	0	0	1	1
BL1	1	1	1	1	0	0	0	0	0	4
BL2	0	0	0	0	0	0	0	0	0	0
BL3	0	0	0	0	1	1	1	1	0	4
BL4	0	0	0	0	0	0	1	1	0	2
BL5	0	0	0	0	1	1	1	1	0	4
BL6	0	0	0	0	0	0	1	1	1	3
BL7	1	1	1	1	0	0	0	0	0	4
BL8	0	0	0	0	0	0	0	0	1	1
BL9	1	1	1	1	0	0	0	0	0	4
BL10	0	0	0	0	0	0	0	0	0	0
BL11	0	0	0	0	1	1	1	1	0	4
BL12	0	0	0	0	0	0	1	1	0	2
BL13	0	0	0	0	1	1	1	1	0	4
BL14	0	0	0	0	0	0	1	1	1	3
BL15	1	1	1	1	0	0	0	0	0	4
BL16	0	0	0	0	0	0	1	1	1	3
BL17	1	1	1	1	0	0	0	0	0	4
BL18	0	0	0	0	0	0	1	1	0	2
BL19	0	0	0	0	1	1	1	1	0	4
BL20	0	0	0	0	0	0	0	0	0	0
BL21	0	0	0	0	1	1	1	1	0	4
BL22	0	0	0	0	0	0	0	0	1	1
BL23	1	1	1	1	0	0	0	0	0	4
BL24	0	0	0	0	0	0	1	1	0	2
BL25	0	0	0	0	1	1	1	1	0	4
BL26	0	0	0	0	0	0	1	1	1	3
BL27	1	1	1	1	0	0	0	0	0	4
BL28	0	0	0	0	0	0	0	0	1	1
BL29	1	1	1	1	0	0	0	0	0	4
BL30	0	0	0	0	0	0	0	0	0	0
BL31	0	0	0	0	1	1	1	1	0	4
BL32	0	0	0	0	0	0	0	0	1	1
BL33	1	1	1	1	0	0	0	0	0	4
BL34	0	0	0	0	0	0	0	0	0	0
BL35	0	0	0	0	1	1	1	1	0	4
BL36	0	0	0	0	0	0	1	1	0	2
BL37	0	0	0	0	1	1	1	1	0	4
BL38	0	0	0	0	0	0	1	1	1	3
BL39	1	1	1	1	0	0	0	0	0	4
BL40	0	0	0	0	0	0	0	0	1	1
BL41	1	1	1	1	0	0	0	0	0	4
BL42	0	0	0	0	0	0	0	0	0	0
BL43	0	0	0	0	1	1	1	1	0	4
BL44	0	0	0	0	0	0	1	1	0	2
BL45	0	0	0	0	1	1	1	1	0	4

DBI ON case										No. of 1's
	DQ[7]	DQ[6]	DQ[5]	DQ[4]	DQ[3]	DQ[2]	DQ[1]	DQ[0]	DBI	
BL46	0	0	0	0	0	0	1	1	1	3
BL47	1	1	1	1	0	0	0	0	0	4
BL48	0	0	0	0	0	0	1	1	1	3
BL49	1	1	1	1	0	0	0	0	0	4
BL50	0	0	0	0	0	0	1	1	0	2
BL51	0	0	0	0	1	1	1	1	0	4
BL52	0	0	0	0	0	0	0	0	0	0
BL53	0	0	0	0	1	1	1	1	0	4
BL54	0	0	0	0	0	0	0	0	1	1
BL55	1	1	1	1	0	0	0	0	0	4
BL56	0	0	0	0	0	0	1	1	0	2
BL57	0	0	0	0	1	1	1	1	0	4
BL58	0	0	0	0	0	0	1	1	1	3
BL59	1	1	1	1	0	0	0	0	0	4
BL60	0	0	0	0	0	0	0	0	1	1
BL61	1	1	1	1	0	0	0	0	0	4
BL62	0	0	0	0	0	0	0	0	0	0
BL63	0	0	0	0	1	1	1	1	0	4
No. of 1's	16	16	16	16	16	16	32	32	16	

Notes

1. Green colored cells are DBI enabled burst.

Table 127 - Data Pattern for IDD4R (DBI on) for BL=32

DBI ON case										No. of 1's
	DQ[7]	DQ[6]	DQ[5]	DQ[4]	DQ[3]	DQ[2]	DQ[1]	DQ[0]	DBI	
BL0	0	0	0	0	0	0	0	0	1	1
BL1	1	1	1	1	0	0	0	0	0	4
BL2	0	0	0	0	0	0	0	0	0	0
BL3	0	0	0	0	1	1	1	1	0	4
BL4	0	0	0	0	0	0	1	1	0	2
BL5	0	0	0	0	1	1	1	1	0	4
BL6	0	0	0	0	0	0	1	1	1	3
BL7	1	1	1	1	0	0	0	0	0	4
BL8	0	0	0	0	0	0	0	0	1	1
BL9	1	1	1	1	0	0	0	0	0	4
BL10	0	0	0	0	0	0	0	0	0	0
BL11	0	0	0	0	1	1	1	1	0	4
BL12	0	0	0	0	0	0	1	1	0	2
BL13	0	0	0	0	1	1	1	1	0	4
BL14	0	0	0	0	0	0	1	1	1	3
BL15	1	1	1	1	0	0	0	0	0	4
BL16	0	0	0	0	0	0	0	0	1	1
BL17	1	1	1	1	0	0	0	0	0	4
BL18	0	0	0	0	0	0	0	0	0	0
BL19	0	0	0	0	1	1	1	1	0	4
BL20	0	0	0	0	0	0	1	1	1	3
BL21	1	1	1	1	0	0	0	0	0	4
BL22	0	0	0	0	0	0	1	1	0	2
BL23	0	0	0	0	1	1	1	1	0	4
BL24	0	0	0	0	0	0	0	0	0	0
BL25	0	0	0	0	1	1	1	1	0	4
BL26	0	0	0	0	0	0	0	0	1	1
BL27	1	1	1	1	0	0	0	0	0	4
BL28	0	0	0	0	0	0	1	1	0	2
BL29	0	0	0	0	1	1	1	1	0	4
BL30	0	0	0	0	0	0	1	1	1	3
BL31	1	1	1	1	0	0	0	0	0	4
BL32	0	0	0	0	0	0	0	0	1	1
BL33	1	1	1	1	0	0	0	0	0	4
BL34	0	0	0	0	0	0	0	0	0	0
BL35	0	0	0	0	1	1	1	1	0	4
BL36	0	0	0	0	0	0	1	1	0	2
BL37	0	0	0	0	1	1	1	1	0	4
BL38	0	0	0	0	0	0	1	1	1	3
BL39	1	1	1	1	0	0	0	0	0	4
BL40	0	0	0	0	0	0	0	0	1	1
BL41	1	1	1	1	0	0	0	0	0	4
BL42	0	0	0	0	0	0	0	0	0	0
BL43	0	0	0	0	1	1	1	1	0	4
BL44	0	0	0	0	0	0	1	1	0	2
BL45	0	0	0	0	1	1	1	1	0	4

DBI ON case										No. of 1's
	DQ[7]	DQ[6]	DQ[5]	DQ[4]	DQ[3]	DQ[2]	DQ[1]	DQ[0]	DBI	
BL46	0	0	0	0	0	0	1	1	1	3
BL47	1	1	1	1	0	0	0	0	0	4
BL48	0	0	0	0	0	0	0	0	1	1
BL49	1	1	1	1	0	0	0	0	0	4
BL50	0	0	0	0	0	0	0	0	0	0
BL51	0	0	0	0	1	1	1	1	0	4
BL52	0	0	0	0	0	0	1	1	1	3
BL53	1	1	1	1	0	0	0	0	0	4
BL54	0	0	0	0	0	0	1	1	0	2
BL55	0	0	0	0	1	1	1	1	0	4
BL56	0	0	0	0	0	0	0	0	0	0
BL57	0	0	0	0	1	1	1	1	0	4
BL58	0	0	0	0	0	0	0	0	1	1
BL59	1	1	1	1	0	0	0	0	0	4
BL60	0	0	0	0	0	0	1	1	0	2
BL61	0	0	0	0	1	1	1	1	0	4
BL62	0	0	0	0	0	0	1	1	1	3
BL63	1	1	1	1	0	0	0	0	0	4
No. of 1's	16	16	16	16	16	16	32	32	16	

Notes

1. Green colored cells are DBI enabled burst.

7.2. IDD Specifications

IDD values are for the entire operating voltage range, and all of them are for the entire standard range, with the exception of IDD6ET which is for the entire extended temperature range. The values described below is the specification for 2ch based measurement

Table 128 - LPDDR4 IDD Specification Parameters and Operating Conditions

Parameter/Condition	Symbol	Power Supply	Units	Notes
Operating one bank active-precharge current: tCK = tCKmin; tRC = tRCmin; CKE is HIGH; CS is LOW between valid commands; CA bus inputs are switching; Data bus inputs are stable; ODT disabled	IDD0 ₁	VDD1	mA	
	IDD0 ₂	VDD2	mA	
	IDD0 _Q	VDDQ	mA	3
Idle power-down standby current: tCK = tCKmin; CKE is LOW; CS is LOW; All banks are idle; CA bus inputs are switching; Data bus inputs are stable; ODT disabled	IDD2P ₁	VDD1	mA	
	IDD2P ₂	VDD2	mA	
	IDD2P _Q	VDDQ	mA	3
Idle power-down standby current with clock stop: CK _t =LOW, CK _c =HIGH; CKE is LOW; CS is LOW; All banks are idle; CA bus inputs are stable; Data bus inputs are stable ODT disabled	IDD2PS ₁	VDD1	mA	
	IDD2PS ₂	VDD2	mA	
	IDD2PS _Q	VDDQ	mA	3
Idle non power-down standby current: tCK = tCKmin; CKE is HIGH; CS is LOW; All banks are idle; CA bus inputs are switching; Data bus inputs are stable ODT disabled	IDD2N ₁	VDD1	mA	
	IDD2N ₂	VDD2	mA	
	IDD2N _Q	VDDQ	mA	3
Idle non power-down standby current with clock stopped: CK _t =LOW; CK _c =HIGH; CKE is HIGH; CS is LOW; All banks are idle; CA bus inputs are stable; Data bus inputs are stable ODT disabled	IDD2NS ₁	VDD1	mA	
	IDD2NS ₂	VDD2	mA	
	IDD2NS _Q	VDDQ	mA	3
Active power-down standby current: tCK = tCKmin; CKE is LOW; CS is LOW; One bank is active; CA bus inputs are switching; Data bus inputs are stable ODT disabled	IDD3P ₁	VDD1	mA	
	IDD3P ₂	VDD2	mA	
	IDD3P _Q	VDDQ	mA	3

Parameter/Condition	Symbol	Power Supply	Units	Notes
Active power-down standby current with clock stop: CK_t=LOW, CK_c=HIGH; CKE is LOW; CS is LOW; One bank is active; CA bus inputs are stable; Data bus inputs are stable ODT disabled	IDD3PS ₁	VDD1	mA	
	IDD3PS ₂	VDD2	mA	
	IDD3PS _Q	VDDQ	mA	4
Active non-power-down standby current: tCK = tCKmin; CKE is HIGH; CS is LOW; One bank is active; CA bus inputs are switching; Data bus inputs are stable ODT disabled	IDD3N ₁	VDD1	mA	
	IDD3N ₂	VDD2	mA	
	IDD3N _Q	VDDQ	mA	4
Active non-power-down standby current with clock stopped: CK_t=LOW, CK_c=HIGH; CKE is HIGH; CS is LOW; One bank is active; CA bus inputs are stable; Data bus inputs are stable ODT disabled	IDD3NS ₁	VDD1	mA	
	IDD3NS ₂	VDD2	mA	
	IDD3NS _Q	VDDQ	mA	4
Operating burst READ current: tCK = tCKmin; CS is LOW between valid commands; One bank is active; BL = 16 or 32; RL = RL(MIN); CA bus inputs are switching; 50% data change each burst transfer ODT disabled	IDD4R ₁	VDD1	mA	
	IDD4R ₂	VDD2	mA	
	IDD4R _Q	VDDQ	mA	5
Operating burst WRITE current: tCK = tCKmin; CS is LOW between valid commands; One bank is active; BL = 16 or 32; WL = WLmin; CA bus inputs are switching; 50% data change each burst transfer ODT disabled	IDD4W ₁	VDD1	mA	
	IDD4W ₂	VDD2	mA	
	IDD4W _Q	VDDQ	mA	4
All-bank REFRESH Burst current: tCK = tCKmin; CKE is HIGH between valid commands; tRC = tRFCabmin; Burst refresh; CA bus inputs are switching; Data bus inputs are stable; ODT disabled	IDD5 ₁	VDD1	mA	
	IDD5 ₂	VDD2	mA	
	IDD5 _Q	VDDQ	mA	4
All-bank REFRESH Average current: tCK = tCKmin; CKE is HIGH between valid commands; tRC = tREFI; CA bus inputs are switching; Data bus inputs are stable; ODT disabled	IDD5AB ₁	VDD1	mA	
	IDD5AB ₂	VDD2	mA	
	IDD5AB _Q	VDDQ	mA	4

Parameter/Condition	Symbol	Power Supply	Units	Notes
Per-bank REFRESH Average current: tCK = tCKmin; CKE is HIGH between valid commands; tRC = tREFI/8; CA bus inputs are switching; Data bus inputs are stable; ODT disabled	IDD5PB ₁	VDD1	mA	
	IDD5PB ₂	VDD2	mA	
	IDD5PB _Q	VDDQ	mA	4
Self refresh current (85°C): CK_t=LOW, CK_c=HIGH; CKE is LOW; CA bus inputs are stable; Data bus inputs are stable; Maximum 1x Self-Refresh Rate; ODT disabled	IDD6 ₁	VDD1	mA	6,7,8,10
	IDD6 ₂	VDD2	mA	6,7,8,10
	IDD6 _Q	VDDQ	mA	4,6,7,8,10
Self refresh current (45°C): CK_t=LOW, CK_c=HIGH; CKE is LOW; CA bus inputs are stable; Data bus inputs are stable; Maximum 1x Self-Refresh Rate; ODT disabled	IDD6 ₁	VDD1	mA	6,7,8,10
	IDD6 ₂	VDD2	mA	6,7,8,10
	IDD6 _Q	VDDQ	mA	4,6,7,8,10
Self refresh current (25°C): CK_t=LOW, CK_c=HIGH; CKE is LOW; CA bus inputs are stable; Data bus inputs are stable; Maximum 1x Self-Refresh Rate; ODT disabled	IDD6 ₁	VDD1	mA	6,7,8,10
	IDD6 ₂	VDD2	mA	6,7,8,10
	IDD6 _Q	VDDQ	mA	4,6,7,8,10
Self refresh current (105°C): CK_t=LOW, CK_c=HIGH; CKE is LOW; CA bus inputs are stable; Data bus inputs are stable; Maximum 1x Self-Refresh Rate; ODT disabled	IDD6ET ₁	VDD1	mA	7,8,11
	IDD6ET ₂	VDD2	mA	7,8,11
	IDD6ET _Q	VDDQ	mA	4,7,8,11

Notes

1. Published IDD values are the maximum of the distribution of the arithmetic mean.
2. ODT disabled: MR11[2:0] = 000B.
3. IDD current specifications are tested after the device is properly initialized.
4. Measured currents are the summation of VDDQ and VDD2.
5. Guaranteed by design with output load = 5pF and RON = 40 ohm.
6. The 1x Self-Refresh Rate is the rate at which the LPDDR4 device is refreshed internally during Self-Refresh, before going into the elevated Temperature range.
7. This is the general definition that applies to full array Self Refresh.
8. Supplier datasheets may contain additional Self Refresh IDD values for temperature subranges within the Standard or elevated Temperature Ranges.
9. For all IDD measurements, VIHCKE = 0.8 x VDD2, VILCKE = 0.2 x VDD2.
10. IDD6 up to 85°C is guaranteed, and it is typical value of the distribution of the arithmetic mean.
11. IDD6ET is a typical value, is sampled only, and is not tested.

8. Electrical Characteristics and AC Timing

8.1. Clock Specification

The jitter specified is a random jitter meeting a Gaussian distribution. Input clocks violating the min/max values may result in malfunction of the LPDDR4 device.

8.1.1. Definition for tCK(avg) and nCK

tCK(avg) is calculated as the average clock period across any consecutive 200 cycle window, where each clock period is calculated from rising edge to rising edge.

$$tCK(avg) = \left(\sum_{j=1}^N tCK_j \right) / N$$

where $N = 200$

Unit 'tCK(avg)' represents the actual clock average tCK(avg) of the input clock under operation. Unit 'nCK' represents one clock cycle of the input clock, counting the actual clock edges. tCK(avg) may change by up to +/-1% within a 100 clock cycle window, provided that all jitter and timing specs are met.

8.1.2. Definition for tCK(abs)

tCK(abs) is defined as the absolute clock period, as measured from one rising edge to the next consecutive rising edge. tCK(abs) is not subject to production test.

8.1.3. Definition for tCH(avg) and tCL(avg)

tCH(avg) is defined as the average high pulse width, as calculated across any consecutive 200 high pulses.

$$tCH(avg) = \left(\sum_{j=1}^N tCH_j \right) / (N \times tCK(avg))$$

where $N = 200$

tCL(avg) is defined as the average low pulse width, as calculated across any consecutive 200 low pulses.

$$tCL(avg) = \left(\sum_{j=1}^N tCL_j \right) / (N \times tCK(avg))$$

where $N = 200$

8.1.4. Definition for tCH(abs) and tCL(abs)

tCH(abs) is the absolute instantaneous clock high pulse width, as measured from one rising edge to the following falling edge.

tCL(abs) is the absolute instantaneous clock low pulse width, as measured from one falling edge to the following rising edge.

Both tCH(abs) and tCL(abs) are not subject to production test.

8.1.5. Definition for tJIT(per)

tJIT(per) is the single period jitter defined as the largest deviation of any signal tCK from tCK(avg).

$tJIT(per) = \text{Min/max of } \{tCK_i - tCK(avg) \text{ where } i = 1 \text{ to } 200\}.$

tJIT(per),act is the actual clock jitter for a given system.

tJIT(per),allowed is the specified allowed clock period jitter.

tJIT(per) is not subject to production test.

8.1.6. Definition for tJIT(cc)

tJIT(cc) is defined as the absolute difference in clock period between two consecutive clock cycles.

$tJIT(cc) = \text{Max of } |\{tCK(i+1) - tCK(i)\}|.$

tJIT(cc) defines the cycle to cycle jitter.

tJIT(cc) is not subject to production test.

8.2. Clock Timing
Table 129 - Clock timings

Parameter	Symbol	min max	1600	2400	3200	3733	4266	Unit	Note
Average Clock Period	tCK (avg)	min	1.25	0.833	0.625	0.536	0.468	ns	
		max	100	100	100	100	100		
Average high pulse width	tCH (avg)	min	0.46	0.46	0.46	0.46	tbd	tCK (avg)	
		max	0.54	0.54	0.54	0.54	tbd		
Average low pulse width	tCL (avg)	min	0.46	0.46	0.46	0.46	tbd	tCK (avg)	
		max	0.54	0.54	0.54	0.54	tbd		
Absolute Clock Period	tCK (abs)	min	tCK(avg)min + tJIT(per)min					ns	
		max	-						
Absolute clock HIGH pulse width	tCH (abs)	min	0.43	0.43	0.43	0.43	tbd	tCK (avg)	
		max	0.57	0.57	0.57	0.57	tbd		
Absolute clock LOW pulse width	tCL (abs)	min	0.43	0.43	0.43	0.43	tbd	tCK (avg)	
		max	0.57	0.57	0.57	0.57	tbd		
Clock Period Jitter	tJIT (per)	min	-70	-50	-40	-40	tbd	ps	
		max	70	50	40	40	tbd		
Maximum Clock Jitter between two consecutive clock cycles	tJIT (cc)	min	-					ps	
		max	140	100	80	80	tbd		

8.3. Temperature Derating for AC Timing

Table 130 - Temperature Derating for AC timing

Parameter	Symbol	min max	533	1066	1600	2133	2667	3200	3733	4266	Unit	Note
DQS output access time from CK_t/CK_c (derated)	tDQSCK	max	3600								ps	
RAS-to-CAS delay (derated)	tRCD	min	tRCD + 1.875								ns	
ACTIVATE-to- ACTIVATE command period (derated)	tRC	min	tRC + 3.75								ns	
Row active time (derated)	tRAS	min	tRAS + 1.875								ns	
Row precharge time (derated)	tRP	min	tRP + 1.875								ns	
Active bank A to active bank B (derated)	tRRD	min	tRRD + 1.875								ns	

Notes

1. Timing derating applies for operation at 85°C to 105°C

8.4. CA Rx voltage and timing

The command and address(CA) including CS input receiver compliance mask for voltage and timing is shown in the figure below. All CA, CS signals apply the same compliance mask and operate in single data rate mode.

The CA input receiver mask for voltage and timing is shown in the figure below is applied across all CA pins. The receiver mask (Rx Mask) defines the area that the input signal must not encroach in order for the DRAM input receiver to be expected to be able to successfully capture a valid input signal; it is not the valid data-eye.

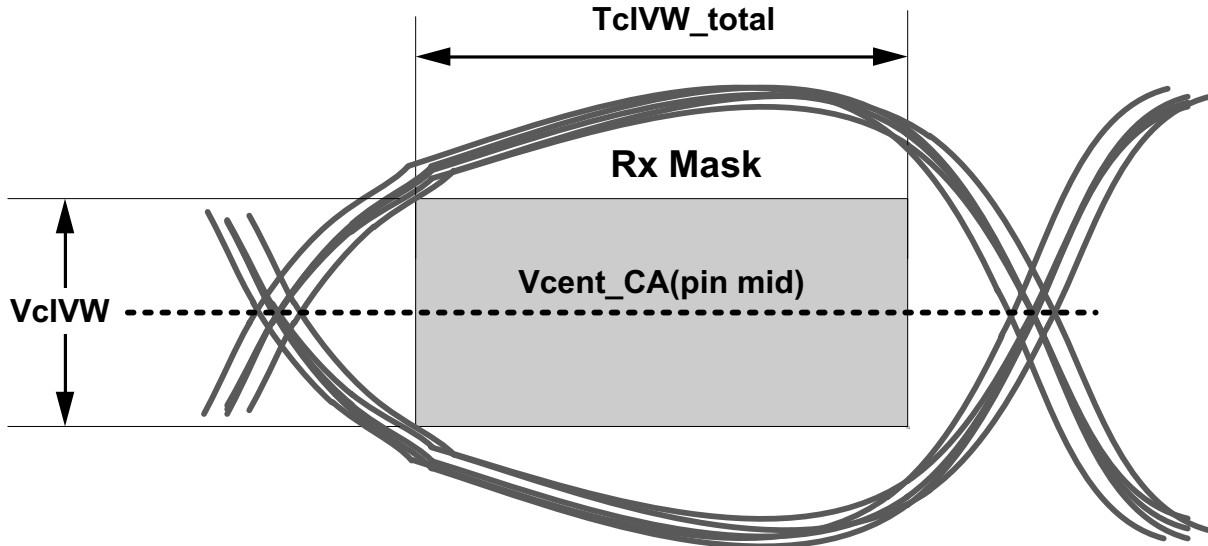

Figure 174 - CA Receiver(Rx) mask

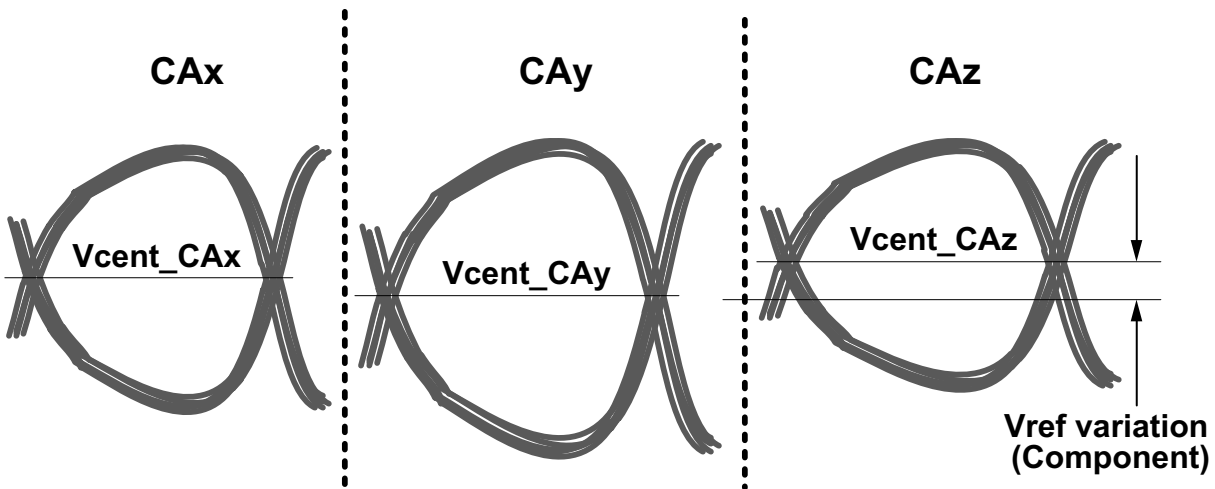
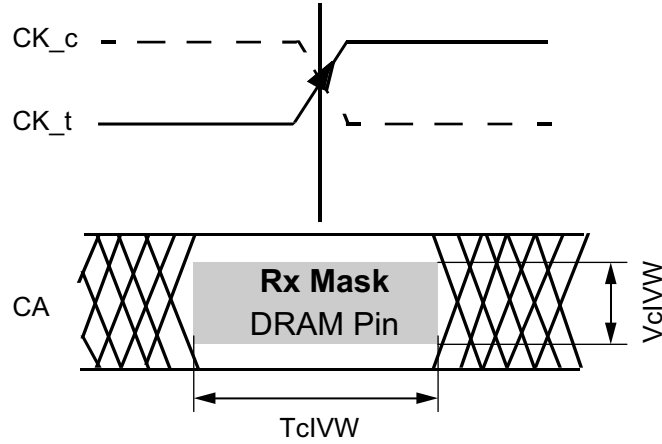

Figure 175 - Across pin Vref CA voltage variation

Vcent_CA(pin avg) is defined as the midpoint between the largest Vcent_CA voltage level and the smallest Vcent_CA voltage level across all CA and CS pins for a given DRAM component. Each CA pin Vcent level is defined by the center, i.e. widest opening, of the cumulative data input eye as depicted in the above figure. This clarifies that any DRAM component level variation must be accounted for within the DRAM CA Rx mask. The component level Vref will be set by the system to account for Ron and ODT settings.

CK_t, CK_c Data-in at DRAM Pin

Minimum CA Eye center aligned



TcIVW for all CA signals is defined as centered on the CK_t/CK_c crossing at the DRAM pin.

Figure 176 - CA Timing at the DRAM pins

All of the timing terms in figure 150 are measured from the CK_t/CK_c to the center(midpoint) of the TcIVW window taken at the VcIVW_total voltage levels centered around Vcent_CA(pin mid).

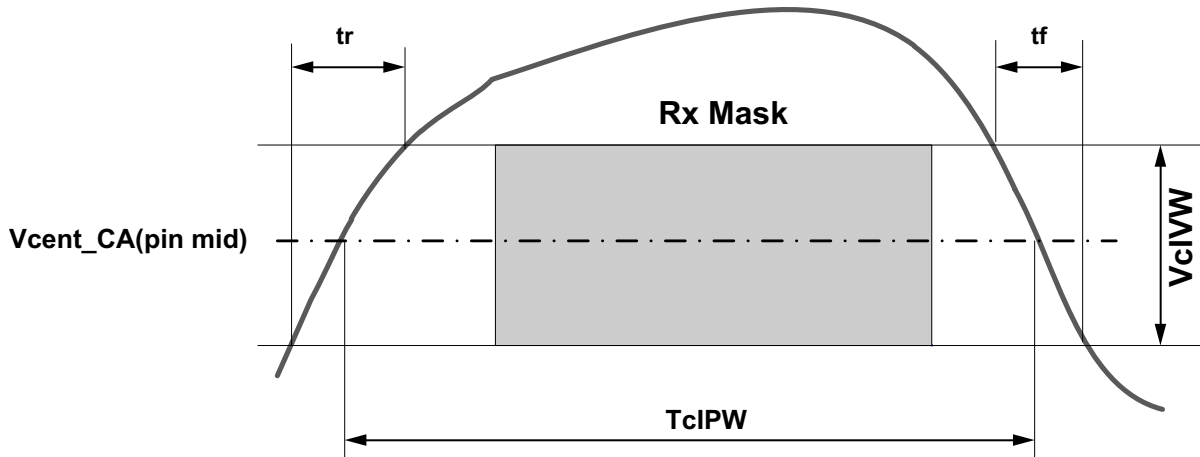

Note
1. $SRIN_{cIVW} = VcIVW_{Total} / (tr \text{ or } tf)$, signal must be monotonic within tr and tf range.

Figure 177 - CA TcIPW and SRIN_cIVW definition (for each input pulse)

Notes:
1. $SRIN_{cIVW} = VcIVW / (tr \text{ or } tf)$, signal must be monotonic within tr and tf range.

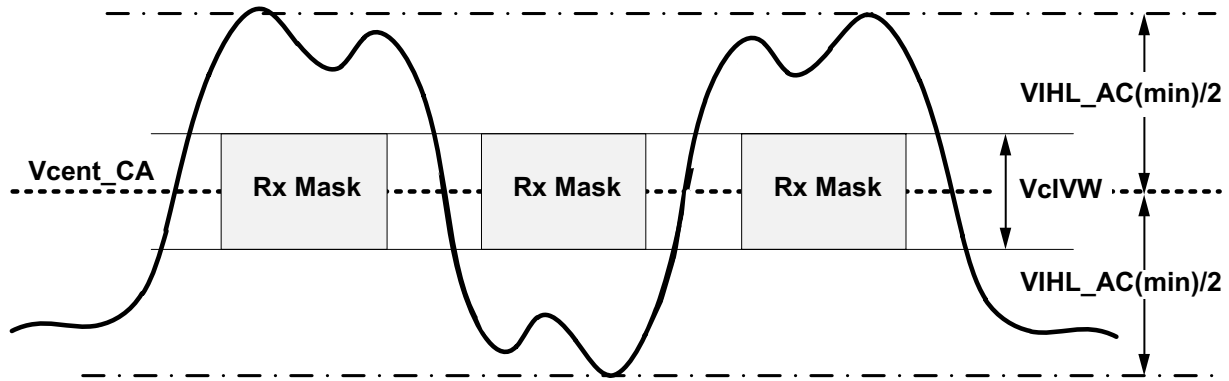
Figure 178 - CA VIHIL_AC definition (for each input pulse)
Table 131 - Command Address Input Parameters

Parameter	Symbol	min max	DQ-1333 ^{A)}	DQ-1600/ 1867	DQ-3200	DQ-3733	DQ-4266	Unit	Note
Rx Mask voltage - p-p	VcIVW	max	175	175	155	155	145	mV	1,2,3
Rx timing window	TcIVW	max	0.3	0.3	0.3	0.3	0.3	UI	1,2,3
CA AC input pulse amplitude pk-pk	VIHL_AC	min	210	210	190	190	180	mV	4,7
CA input pulse width	TcIPW	min	0.55	0.55	0.6	0.6	0.6	UI	5
Input Slew Rate over VcIVW	SRIN_cIVW	min	1	1	1	1	1	V/ns	6
		max	7	7	7	7	7		

A. The following Rx voltage and absolute timing requirements apply for DQ operating frequencies at or below 1333 for all speed bins. For example the TcIVW(ps) = 450ps at or below 1333 operating frequencies.

Notes

1. CA Rx mask voltage and timing parameters at the pin including voltage and temperature drift.
2. Rx mask voltage VcIVW total(max) must be centered around Vcent_CA(pin mid).
3. Vcent_CA must be within the adjustment range of the CA internal Vref.
4. CA only input pulse signal amplitude into the receiver must meet or exceed VIHIL AC at any point over the total UI. No timing requirement above level. VIHIL AC is the peak to peak voltage centered around Vcent_CA(pin mid) such that VIHIL_AC/2 min must be met both above and below Vcent_CA.
5. CA only minimum input pulse width defined at the Vcent_CA(pin mid).
6. Input slew rate over VcIVW Mask centered at Vcent_CA(pin mid).
7. VIHIL_AC does not have to be met when no transitions are occurring.

8.5. DRAM Data Timing

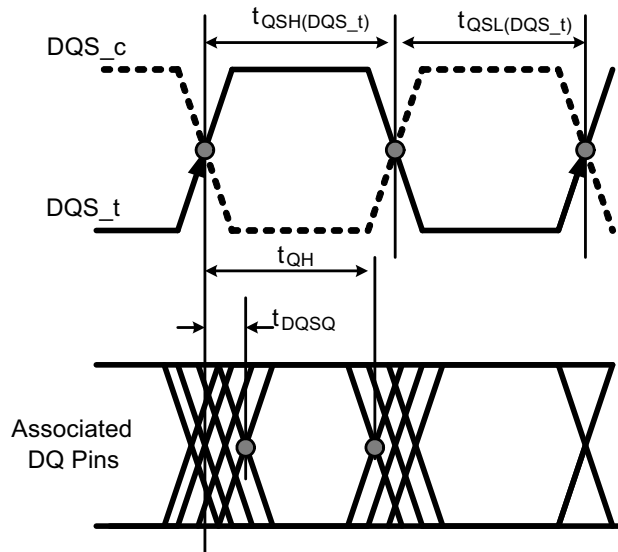

Figure 179 - Read data timing definitions t_{QH} and t_{DQSQ} across on DQ signals per DQS group

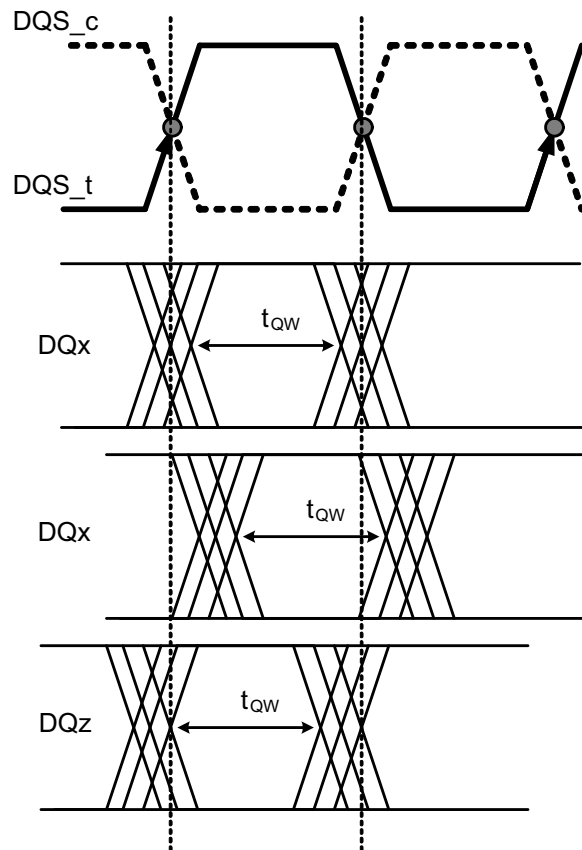

Figure 180 - Read data timing t_{QW} valid window defined per DQ signal

Table 132 - Read Output timings

Parameter	Symbol	min max	1600/ 1867	2133/ 2400	3200	3733	4266	Unit	Note
Data Timing									
DQS_t,DQS_c to DQ Skew total, per group, per access (DBIDisabled)	tDQSQ	max	0.18					UI	
DQ output hold time total from DQS_t, DQS_c (DBI-Disabled)	tQH	min	min(tQSH, tQSL)					UI	
DQ output window time total, per pin (DBI-Disabled)	tQW_total	min	0.75	0.73	0.7	0.7	0.7	UI	3
DQ output window time deterministic, per pin (DBIDisabled)	tQW_dj	min	tbd	tbd	tbd	tbd	tbd	UI	2,3
DQS_t,DQS_c to DQ Skew total,per group, per access (DBI-Enabled)	tDQSQ_DBI	max	0.18					UI	
DQ output hold time total from DQS_t, DQS_c (DBI-Enabled)	tQH_DBI	min	min(tQSH_DBI, tQSL_DBI)					UI	
DQ output window time total, per pin (DBI-enabled)	tQW_total_DBI	min	0.75	0.73	0.7	0.7	0.7	UI	3
Data Strobe Timing									
DQS, DQS# differential output low time (DBI-Disabled)	tQSL	min	tCL(abs)-0.05					tCK (avg)	3,4
DQS, DQS# differential output high time (DBI-Disabled)	tQSH	min	tCH(abs)-0.05					tCK (avg)	3,5
DQS, DQS# differential output low time (DBI-Enabled)	tQSL_DBI	min	tCL(abs)-0.045					tCK (avg)	4,6
DQS, DQS# differential output high time (DBI-Enabled)	tQSH_DBI	min	tCH(abs)-0.045					tCK (avg)	5,6

Notes

1. The deterministic component of the total timing. Measurement method tbd.
2. This parameter will be characterized and guaranteed by design.
3. This parameter is function of input clock jitter. These values assume the min tCH(abs) and tCL(abs). When the input clock jitter min tCH(abs) and tCL(abs) is 0.44 or greater of tck(avg) the min value of tQSL will be tCL(abs)-0.04 and tQSH will be tCH(abs) -0.04.
4. tQSL describes the instantaneous differential output low pulse width on DQS_t - DQS_c, as it measured the next rising edge from an arbitrary falling edge.
5. tQSH describes the instantaneous differential output high pulse width on DQS_t - DQS_c, as it measured the next rising edge from an arbitrary falling edge
6. This parameter is function of input clock jitter. These values assume the min tCH(abs) and tCL(abs). When the input clock jitter min tCH(abs) and tCL(abs) is 0.44 or greater of tck(avg) the min value of tQSL will be tCL(abs)-0.04 and tQSH will be tCH(abs) -0.04.

8.6. DQ Rx Voltage and Timing Definition

The DQ input receiver mask for voltage and timing is shown in figure below, is applied per pin. The "total" mask (V_{dIVW_total} , T_{diVW_total}) defines the area the input signal must not encroach in order for the DQ input receiver to successfully capture an input signal with a BER of lower than TBD. The mask is a receiver property and it is not the valid data-eye.

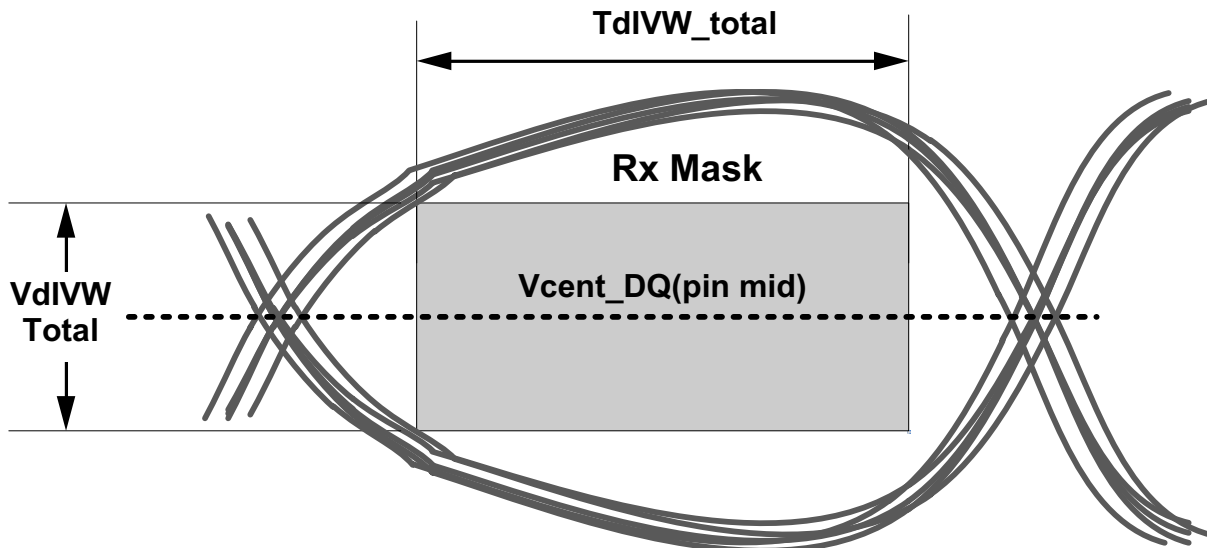

Figure 181 - DQ Receiver(Rx) mask

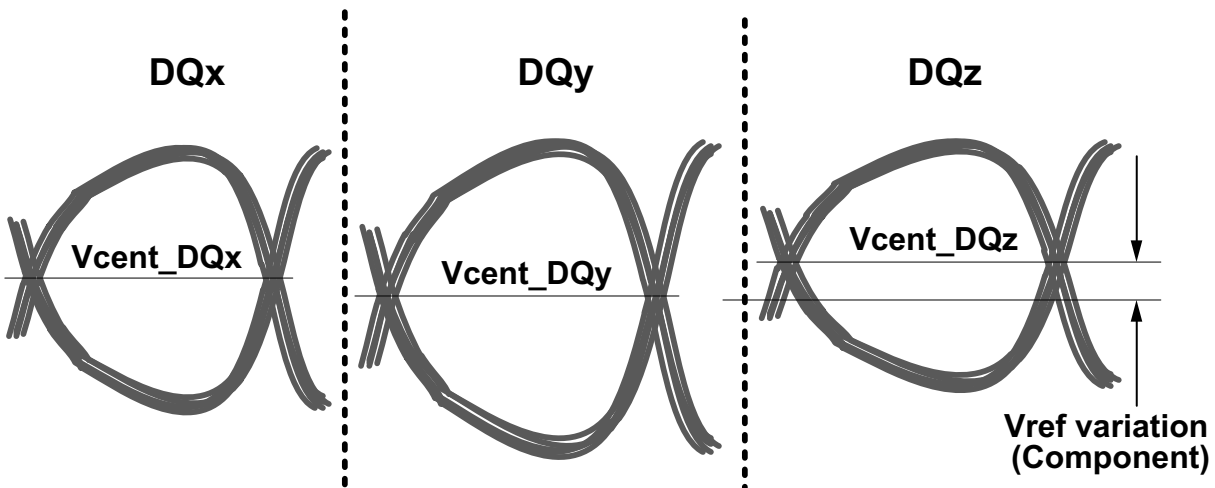

Figure 182 - Across pin Vref DQ voltage variation

$V_{cent_DQ}(pin_mid)$ is defined as the midpoint between the largest V_{cent_DQ} voltage level and the smallest V_{cent_DQ} voltage level across all DQ pins for a given DRAM component. Each DQ V_{cent} is defined by the center, i.e., widest opening, of the cumulative data input eye as depicted in Above Figure. This clarifies that any DRAM component level variation must be accounted for within the DRAM Rx mask. The component level V_{ref} will be set by the system to account for R_{on} and ODT settings.

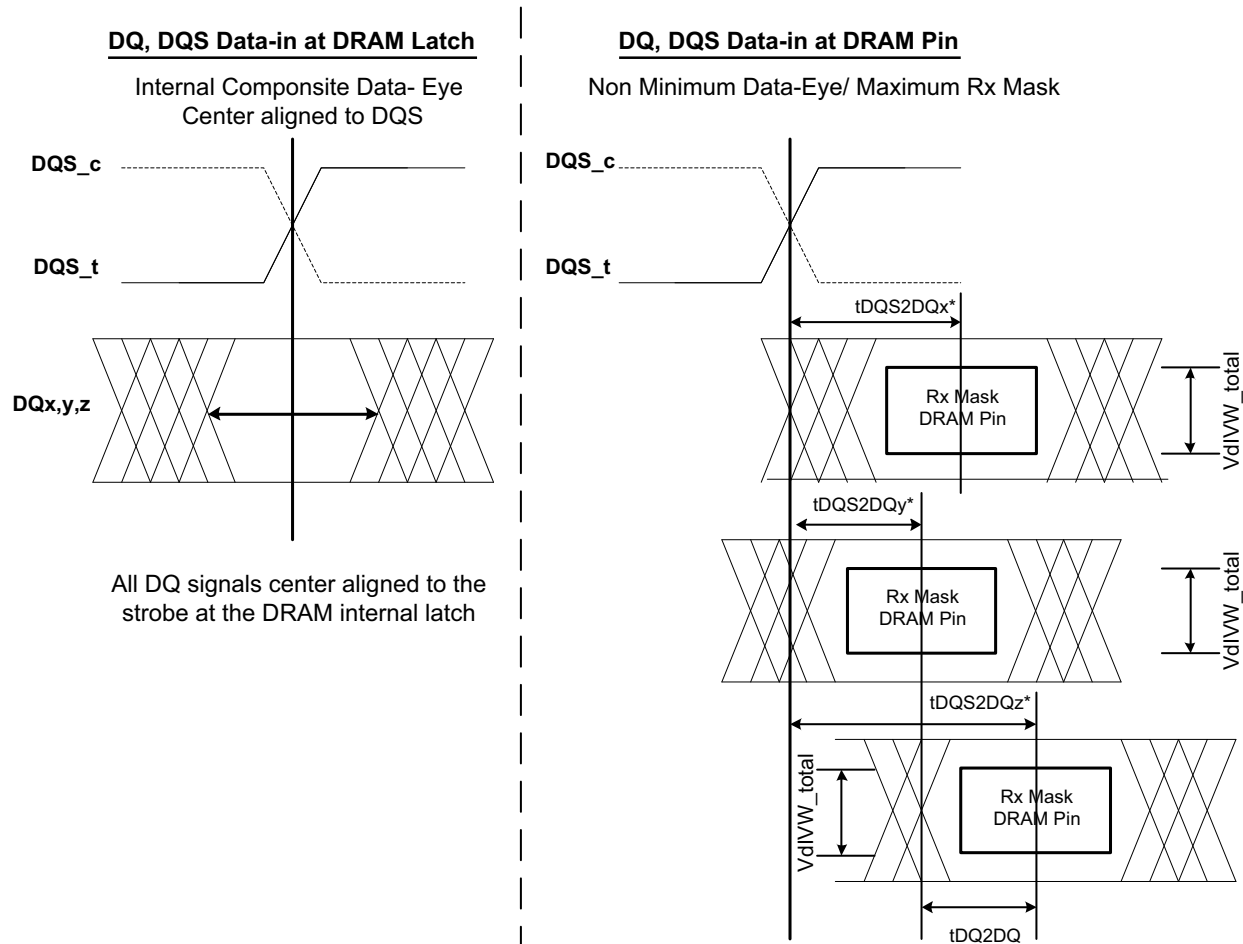
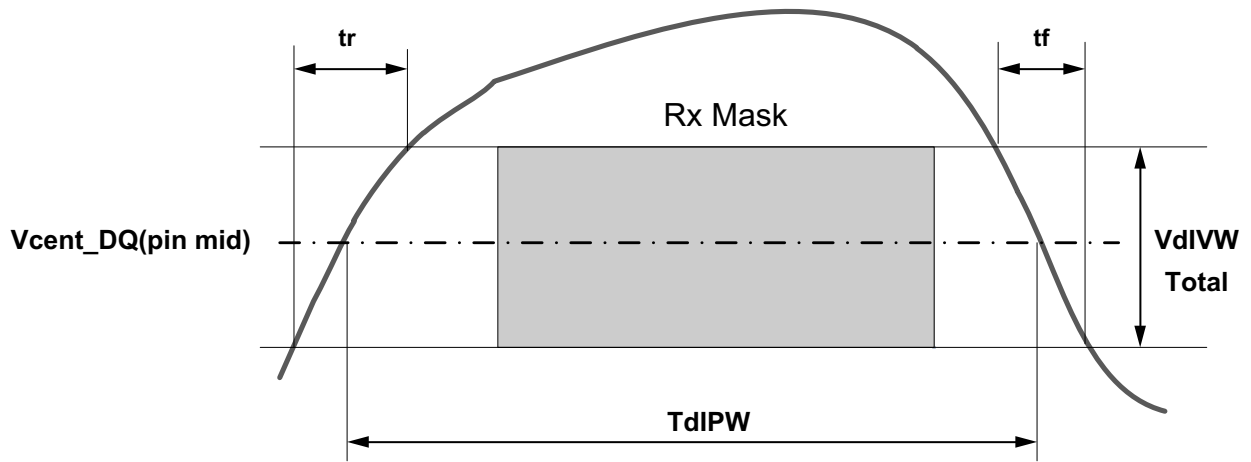

Figure 183 - DQ to DQS (t_{DQS2DQ} and t_{DQ2DQ}) Timings at the DRAM pins referenced from the internal latch

Figure 184 - DQ TdIPW and SRIN_dIVW definition (for each input pulse)



Note
1. $SRIN_dIVW = VdIVW_Total / (tr \text{ or } tf)$, signal must be monotonic within tr and tf range.

Figure 185 - DQ VIH_L_AC definition (for each input pulse)

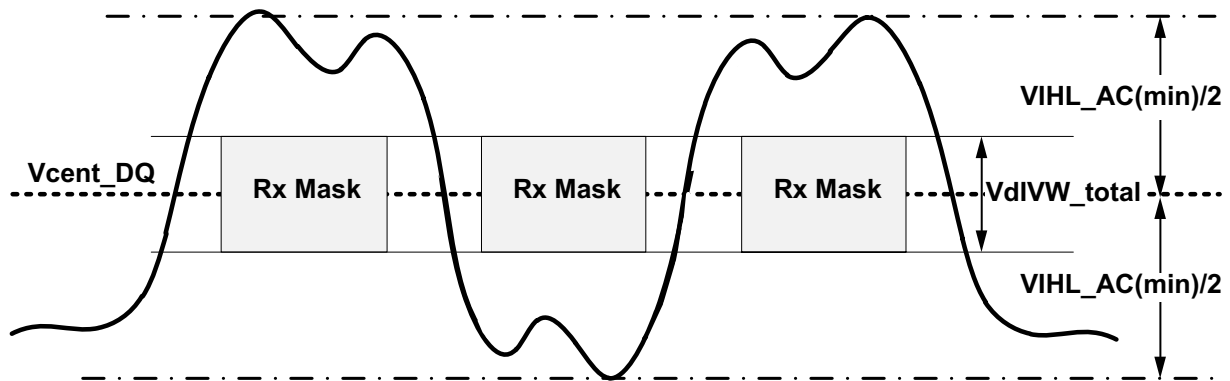

9. IDD Measurement

IDD values are for the entire operating voltage range, and all of them are for the entire standard range, with the exception of IDD6ET which is for the entire extended temperature range.

The values described below is the specification for single die measurement.

The values may vary depending on the state of each die.

Table 120 - LPDDR4 IDD Specification Parameters and Operating Conditions

Parameter/Condition	Symbol	Power Supply	4266 (x16)	4266 (x8)	Units	Notes
Operating one bank active-precharge current: tCK = tCKmin; tRC = tRCmin; CKE is HIGH; CS is LOW between valid commands; CA bus inputs are switching; Data bus inputs are stable; ODT disabled	IDD0 ₁	VDD1	3.50	4.50	mA	
	IDD0 ₂	VDD2	40.00	69.50	mA	
	IDD0 _Q	VDDQ	1.25	2.50	mA	3
Idle power-down standby current: tCK = tCKmin; CKE is LOW; CS is LOW; All banks are idle; CA bus inputs are switching; Data bus inputs are stable; ODT disabled	IDD2P ₁	VDD1	0.90	1.80	mA	
	IDD2P ₂	VDD2	3.45	6.90	mA	
	IDD2P _Q	VDDQ	0.40	0.80	mA	3
Idle power-down standby current with clock stop: CK _t =LOW, CK _c =HIGH; CKE is LOW; CS is LOW; All banks are idle; CA bus inputs are stable; Data bus inputs are stable ODT disabled	IDD2PS ₁	VDD1	0.90	1.80	mA	
	IDD2PS ₂	VDD2	3.45	6.90	mA	
	IDD2PS _Q	VDDQ	0.40	0.80	mA	3
Idle non power-down standby current: tCK = tCKmin; CKE is HIGH; CS is LOW; All banks are idle; CA bus inputs are switching; Data bus inputs are stable ODT disabled	IDD2N ₁	VDD1	0.90	1.80	mA	
	IDD2N ₂	VDD2	18.65	37.30	mA	
	IDD2N _Q	VDDQ	1.25	2.50	mA	3
Idle non power-down standby current with clock stopped: CK _t =LOW; CK _c =HIGH; CKE is HIGH; CS is LOW; All banks are idle; CA bus inputs are stable; Data bus inputs are stable ODT disabled	IDD2NS ₁	VDD1	0.90	1.80	mA	
	IDD2NS ₂	VDD2	15.50	31.20	mA	
	IDD2NS _Q	VDDQ	1.25	2.50	mA	3
Active power-down standby current: tCK = tCKmin; CKE is LOW; CS is LOW; One bank is active; CA bus inputs are switching; Data bus inputs are stable ODT disabled	IDD3P ₁	VDD1	1.50	2.05	mA	
	IDD3P ₂	VDD2	4.945	7.50	mA	
	IDD3P _Q	VDDQ	0.40	0.80	mA	3

Parameter/Condition	Symbol	Power Supply	4266 (x16)	4266 (x8)	Units	Notes
Active power-down standby current with clock stop: CK_t=LOW, CK_c=HIGH; CKE is LOW; CS is LOW; One bank is active; CA bus inputs are stable; Data bus inputs are stable ODT disabled	IDD3PS ₁	VDD1	1.50	2.05	mA	
	IDD3PS ₂	VDD2	4.94	7.50	mA	
	IDD3PS _Q	VDDQ	0.40	0.80	mA	4
Active non-power-down standby current: tCK = tCKmin; CKE is HIGH; CS is LOW; One bank is active; CA bus inputs are switching; Data bus inputs are stable ODT disabled	IDD3N ₁	VDD1	1.50	2.00	mA	
	IDD3N ₂	VDD2	25.00	45.00	mA	
	IDD3N _Q	VDDQ	1.25	2.50	mA	4
Active non-power-down standby current with clock stopped: CK_t=LOW, CK_c=HIGH; CKE is HIGH; CS is LOW; One bank is active; CA bus inputs are stable; Data bus inputs are stable ODT disabled	IDD3NS ₁	VDD1	1.50	2.00	mA	
	IDD3NS ₂	VDD2	22.50	38.85	mA	
	IDD3NS _Q	VDDQ	1.25	2.50	mA	4
Operating burst READ current: tCK = tCKmin; CS is LOW between valid commands; One bank is active; BL = 16 or 32; RL = RL(MIN); CA bus inputs are switching; 50% data change each burst transfer ODT disabled	IDD4R ₁	VDD1	9.805	10.00	mA	
	IDD4R ₂	VDD2	240.825	344.50	mA	
	IDD4R _Q	VDDQ	91.77	100.00	mA	5
Operating burst WRITE current: tCK = tCKmin; CS is LOW between valid commands; One bank is active; BL = 16 or 32; WL = WLmin; CA bus inputs are switching; 50% data change each burst transfer ODT disabled	IDD4W ₁	VDD1	9.795	10.00	mA	
	IDD4W ₂	VDD2	211.51	294.50	mA	
	IDD4W _Q	VDDQ	1.25	2.50	mA	4
All-bank REFRESH Burst current: tCK = tCKmin; CKE is HIGH between valid commands; tRC = tRFCabmin; Burst refresh; CA bus inputs are switching; Data bus inputs are stable; ODT disabled	IDD5 ₁	VDD1	13.20	26.40	mA	
	IDD5 ₂	VDD2	95.905	191.80	mA	
	IDD5 _Q	VDDQ	1.25	2.50	mA	4
All-bank REFRESH Average current: tCK = tCKmin; CKE is HIGH between valid commands; tRC = tREFI; CA bus inputs are switching; Data bus inputs are stable; ODT disabled	IDD5AB ₁	VDD1	2.00	4.00	mA	
	IDD5AB ₂	VDD2	24.50	49.00	mA	
	IDD5AB _Q	VDDQ	1.25	2.50	mA	4

Parameter/Condition	Symbol	Power Supply	4266 (x16)	4266 (x8)	Units	Notes
Per-bank REFRESH Average current: tCK = tCKmin; CKE is HIGH between valid commands; tRC = tREFI/8; CA bus inputs are switching; Data bus inputs are stable; ODT disabled	IDD5PB ₁	VDD1	2.00	4.00	mA	
	IDD5PB ₂	VDD2	24.50	49.00	mA	
	IDD5PB _Q	VDDQ	1.25	2.50	mA	4
Self refresh current (85°C): CK _t =LOW, CK _c =HIGH; CKE is LOW; CA bus inputs are stable; Data bus inputs are stable; Maximum 1x Self-Refresh Rate; ODT disabled	IDD6 ₁	VDD1	3.00	6.00	mA	6,7,8,10
	IDD6 ₂	VDD2	10.00	20.00	mA	6,7,8,10
	IDD6 _Q	VDDQ	0.40	0.80	mA	4,6,7,8,10
Self refresh current (45°C): CK _t =LOW, CK _c =HIGH; CKE is LOW; CA bus inputs are stable; Data bus inputs are stable; Maximum 1x Self-Refresh Rate; ODT disabled	IDD6 ₁	VDD1	0.195	0.39	mA	6,7,8,10
	IDD6 ₂	VDD2	0.75	1.50	mA	6,7,8,10
	IDD6 _Q	VDDQ	0.05	0.10	mA	4,6,7,8,10
Self refresh current (25°C): CK _t =LOW, CK _c =HIGH; CKE is LOW; CA bus inputs are stable; Data bus inputs are stable; Maximum 1x Self-Refresh Rate; ODT disabled	IDD6 ₁	VDD1	0.165	0.33	mA	6,7,8,10
	IDD6 ₂	VDD2	0.41	0.815	mA	6,7,8,10
	IDD6 _Q	VDDQ	0.05	0.105	mA	4,6,7,8,10
Self refresh current (105°C): CK _t =LOW, CK _c =HIGH; CKE is LOW; CA bus inputs are stable; Data bus inputs are stable; Maximum 1x Self-Refresh Rate; ODT disabled	IDD6ET ₁	VDD1	3.025	6.055	mA	7,8,11
	IDD6ET ₂	VDD2	22.555	45.11	mA	7,8,11
	IDD6ET _Q	VDDQ	0.05	0.10	mA	4,7,8,11

Notes

- Published IDD values are the maximum of the distribution of the arithmetic mean.
- ODT disabled: MR11[2:0] = 000B.
- IDD current specifications are tested after the device is properly initialized.
- Measured currents are the summation of VDDQ and VDD2.
- Guaranteed by design with output load = 5pF and RON = 40 ohm.
- The 1x Self-Refresh Rate is the rate at which the LPDDR4 device is refreshed internally during Self-Refresh, before going into the elevated Temperature range.
- This is the general definition that applies to full array Self Refresh.
- Supplier datasheets may contain additional Self Refresh IDD values for temperature subranges within the Standard or elevated Temperature Ranges.
- For all IDD measurements, VIHCKE = 0.8 x VDD2, VILCKE = 0.2 x VDD2.
- IDD6 up to 85°C is guaranteed, and it is typical value of the distribution of the arithmetic mean.
- IDD6ET is a typical value, is sampled only, and is not tested.

10. Revision History

10.1.Document History Page

Document Title: S6AA1616 16Gb x8, 16Gb x16, 1.8 NAND Flash Memory and LPDDR4x DRAM				
Document Number: 003-00008				
Rev.	ECN No.	Orig. of Change	Submission Date	Description of Change
**	—	MNADA	09/25/2023	Initial release
A	—	MNADA	10/24/2023	Update Physical Dimensions
B	—	MNADA	01/22/2024	Update Parameter Page and AC Char. to support timing mode 2
C	—	MNADA	03/01/2024	Update Physical Dimensions Section